

TECHNICAL MANUAL

DIRECT SUPPORT AND GENERAL SUPPORT
MAINTENANCE MANUAL

RADIO SET AN/GRC-106

(FSN 5820-402-2263)

AND

RADIO SET AN/GRC-106A

(FSN 5820-223-7548)

WARNING

DANGEROUS VOLTAGES EXIST IN THIS EQUIPMENT

Voltages as high as 128 volts AC, 3,000 volts DC, and 10,000 volts rf are used in the operation of Amplifier, Radio Frequency AM-3349/GRC-106.

DANGEROUS VOLTAGES EXIST AT THE AM-3349/GRC-106 50-OHM AND WHIP ANTENNA CONNECTORS

Be careful when working around the antenna or antenna connectors. Radio frequency voltages as high as 10,000 volts exist at these points. Operator and maintenance personnel should be familiar with the requirements of TB SIG 291 before attempting installation or operation of Radio Set AN/GRC-106(*).

DEATH ON CONTACT

may result if operating personnel fail to observe safety precautions and follow requirements of TB SIG 291

DO NOT TAKE CHANCES!

CAUTION

Before connecting power leads to the power source, turn Receiver-Transmitter, Radio RT-662/GRC-106 or RT-834/GRC-106 SERVICE SELECTOR switch and Amplifier, Radio Frequency AM-3349/GRC-106 PRIM. PWR. switch to OFF. Make sure that proper polarity of power connections is observed. Transistors in this equipment will be damaged if power connectors are reversed.

If equipment has been operating for longer than 15 minutes, do not turn it off directly but go to a standby for two minutes. This will allow chassis blowers to cool components sufficiently to prevent damage.

TECHNICAL MANUAL }
 No. 11-5820-520-34 }

HEADQUARTERS
 DEPARTMENT OF THE ARMY
 WASHINGTON, D. C., 2 February 1972

Direct Support and General Support Maintenance Manual

RADIO SET AN/GRC-106 (FSN 5820-402-2263)

AND RADIO SET AN/GRC-106A (FSN 5820-223-7548)

	Paragraph	Page
CHAPTER 1. FUNCTIONAL ANALYSIS		
Section I. General	1-1, 1-2	1-1
II. Block diagram analysis of Receiver-Transmitter Radio RT-662/GRC and RT-834/GRC	1-3, 1-4	1-1, 1-4
III. Transmit section circuit analysis, Receiver-Transmitter, Radio RT-662/GRC and RT-834/GRC	1-5-1-8	1-6-1-13
IV. Receiver section circuit analysis, Receiver-Transmitter, Radio RT-662/GRC and RT-834/GRC	1-9-1-13	1-14-1-19
V. Frequency synthesis circuit analysis, Receiver-Transmitter, Radio RT-662/GRC and RT-834/GRC	1-14-1-24	1-22-1-44
VI. Power and operational control, functional circuit analysis, Receiver- Transmitter, Radio, RT-662/GRC and RT-834/GRC	1-25, 1-26	1-46, 1-47
VII. Block diagram functional analysis of amplifier, Radio Frequency AM-3349/GRC-106	1-27, 1-28	1-51, 1-52
VIII. Main signal flow functional circuit analysis of amplifier, Radio Frequency AM-3349/GRC-106	1-29-1-32	1-52-1-55
IX. Power control and protection circuit functional analysis for Amplifier, Radio Frequency AM-3349/GRC-106	1-33-1-37	1-56-1-59
X. Operational control functional circuit analysis of Amplifier, Radio Frequency AM-3349/GRC-106	1-38-1-44	1-60-1-65
XI. Functional description of interunit circuit details	1-45-1-50	1-66-1-72
CHAPTER 2. DIRECT SUPPORT MAINTENANCE		
Section I. Installation of Radio Set AN/GRC-106(*)	2-1-2-3	2-1-2-3
II. Troubleshooting Radio Set AN/GRC-106(*)	2-4-2-7	2-4-2-6
III. Troubleshooting Receiver-Transmitter, Radio RT-662/GRC and RT-834/GRC ..	2-8, 2-9	2-10
IV. Troubleshooting 100 Hz Synthesis, RT-834/GRC	2-10, 2-11	2-35
V. Troubleshooting amplifier, Radio Frequency AM-3349/GRC-106	2-12-2-15	2-37-2-56
VI. Repair and replacement	2-16-2-24	2-64-2-82
VII. Inspection and service	2-25-2-27	2-83-2-85
VIII. Direct support adjustments	2-28-2-30	2-88-2-89
CHAPTER 3. GENERAL SUPPORT MAINTENANCE		
Section I. General	3-1-3-3	3-1-3-2
II. General support troubleshooting	3-4-3-22	3-2-3-25
III. Module adjustments	3-23-3-35	3-33-3-48
IV. Repairs and replacement	3-36-3-39	3-49-3-53
V. Lubrication	3-40, 3-41	3-54
VI. Alignment and Adjustment	3-42-3-48	3-57-3-62
VII. General support testing procedures	3-49, 3-50	3-64
CHAPTER 4. GENERAL SUPPORT MODULE TESTING		
Section I. Module test procedures	4-1-4-3	4-1
II. RT-662/GRC and RT-834/GRC module tests, and AM-3349/GRC-106 assembly tests	4-4-4-6	4-1-4-34
APPENDIX A		A-1
INDEX		Index-1

LIST OF ILLUSTRATIONS

<i>Figure</i>	<i>Title</i>	<i>Page</i>
1-1	Receiver-Transmitter, Radio RT-662/GRC, transmit operation, functional block diagram -----	1-2
1-2	Receiver-Transmitter, Radio RT-662/GRC, receive operation, functional block diagram -----	1-5
1-3	Receiver-Transmitter, Radio RT-662/GRC, frequency scheme, block diagram -----	1-35
1-4	Receiver-Transmitter, Radio RT-662/GRC, error cancellation, block diagram -----	1-36
1-5	Receiver-Transmitter, Radio RT-834/GRC, frequency synthesis, block diagram -----	1-38
1-6	Receiver-Transmitter, Radio RT-834/GRC, 10 and 1 kHz synthesizer 1A4, detailed block diagram -----	1-42
1-7	Receiver-Transmitter, Radio RT-834/GRC, error cancellation, block diagram -----	1-45
1-8	Driver Amplifier 2A8V1, input bridge schematic diagram -----	1-53
1-9	Power Amplifier 2A1A1V1 and 2A1A1V2, neutralization bridge, schematic diagram -----	1-54
1-10	Antenna Coupler Assembly 2A3, bandswitching simplified circuits -----	1-56
1-11	Phase discriminator 2A4A1, vector diagram -----	1-62
1-12	Interconnecting cables between components of Radio Set AN/GRC-106(*) -----	1-72
2-1	Radio Set AN/GRC-106(*), typical installation -----	2-2
2-2	Radio Set AN/GRC-106(*), typical cording diagram -----	2-4
2-3	AM-3349/GRC-106, rear chassis view, test point location -----	2-7
2-4	Test setup for troubleshooting RT-662/GRC and RT-834/GRC -----	2-11
2-5	Pin number identification, internal connectors -----	2-12
2-6	Pin number identification, internal and external connectors -----	2-13
2-7	Printed Circuit Boards 1A1A2, 1A1A3, and 1A1A4, parts location diagram -----	2-14
2-8	RT-662/GRC and RT-834/GRC, internal Alc assembly 1A1A5, parts location diagram -----	2-14
2-9	Test setup for troubleshooting RT-834/GRC -----	2-35
2-10	Test setup for troubleshooting AM-3349/GRC-106 -----	2-38
2-11	Tune APC assembly board 2A1A1A1, parts location diagram -----	2-53
2-12	Coding assembly board 2A2A31, parts location diagram -----	2-54
2-13	Printed circuit board 2A5A4, parts location diagram -----	2-54
2-14	Printed circuit board 2A5A6, parts location diagram -----	2-55
2-15	Printed circuit board 2A8A1, parts location diagram -----	2-56
2-16	Terminal board 2A5A5, parts location diagram -----	2-57
2-17	Dc-to-Ac inverter assembly 2A6A1, parts location diagram -----	2-58
2-18	Plenum assembly group 2A1A1, parts location diagram -----	2-59
2-19	Protection circuit assembly 2A5A7, parts location diagram -----	2-60
2-20	Plate assembly group 2A5A3, parts location diagram -----	2-60
2-21	Filter box assembly 2A5A1, parts location diagram -----	2-61
2-22	Filter box assembly 2A5A1 and 2A5A1A2, parts location diagram -----	2-62
2-23	Driver assembly 2A8, component location -----	2-63
2-24	Stator assembly 2A9, component location -----	2-64
2-25	RT-662/GRC and RT-834/GRC, chassis coupler and connector location -----	2-66
2-26	RT-662/GRC and RT-834/GRC, module and test point location -----	2-67
2-27	Receiver-Transmitter, Radio RT-662/GRC and RT-834/GRC, parts location, bottom view -----	2-69
2-28	Receiver-Transmitter, Radio RT-662/GRC and RT-834/GRC, chassis terminal locations -----	2-70
2-29	Receiver-Transmitter, Radio RT-662/GRC and RT-834/GRC, front panel terminal locations -----	2-71
2-30	Receiver-Transmitter, Radio RT-834/GRC, parts location, bottom view -----	2-72
2-31	Amplifier, Radio Frequency AM-3349/GRC-106, component location, top view -----	2-73
2-32	Amplifier, Radio Frequency AM-3349/GRC-106, component location, bottom view -----	2-74
2-33	AM-3349/GRC-106, front panel assembly 2A5, component location -----	2-75
2-34	AM-3349/GRC-106, front panel assembly 2A5 with dc-to-dc converter assembly 2A5A2 removed -----	2-76

<i>Figure</i>	<i>Title</i>	<i>Page</i>
2-35	AM-3349/GRC-106, front panel assembly 2A5, with protection assembly 2A5A7 removed	2-77
2-36	Antenna coupler assembly 2A3, parts location, front oblique view	2-78
2-37	Antenna coupler assembly 2A3, parts location, rear oblique view	2-79
2-38	Receiver-Transmitter, Radio RT-662/GRC and RT-834/GRC, lubrication points	2-87
2-39	AM-3349/GRC-106, plate trimmer setup	2-90
2-40	Amplifier, Radio Frequency AM-3349/GRC-106, blower protection circuit board 2A1A2, parts location diagram	2-92
2-41	Amplifier, Radio Frequency AM-3349/GRC-106, filament regulator assembly 2A1A2A1, parts location diagram	2-93
2-42	AGC/auto level control	2-94
3-1	Front end protection circuit 1A1A1A10, parts location	3-3
3-2	Terminal board 1A1A1A10A1, parts location diagram	3-4
3-3	Terminal board 1A1A1A10A2, parts location diagram	3-4
3-4	Internal Alc assembly 1A1A2A5, parts location	3-4
3-5	Terminal board 1A1A2A5A1, parts location diagram	3-5
3-6	100 Hz module 1A1A2A8, parts location	3-6
3-7	Terminal board 1A1A2A8A1, parts location diagram	3-8
3-8	Terminal board 1A1A2A8A2, parts location diagram	3-8
3-9	Voltage regulator 1A1A2A9, parts location	3-8
3-10	100 kHz synthesizer module 1A2, parts location	3-9
3-11	Printed circuit boards 1A2A1 and 1A2A4, parts location diagram	3-10
3-12	Printed circuit board 1A2A2, parts location diagram	3-10
3-13	Printed circuit board 1A2A3, parts location diagram	3-10
3-14	Frequency standard module 1A3, parts location	3-11
3-15	Oven assembly 1A3A1, exploded view, parts location diagram	3-12
3-16	Oven assembly 1A3A1, terminal location diagram	3-13
3-17	Printed circuit boards 1A3A1A1-1 and 1A3A1A1-2, parts location diagram	3-13
3-18	Printed circuit board 1A3A1A2, parts location diagram	3-13
3-19	Printed circuit board 1A3A2, parts location diagram	3-13
3-20	Printed circuit board 1A3A3, parts location diagram	3-13
3-21	10 and 1 kHz synthesizer module 1A4, parts location	3-16
3-22(1)	RT-662/GRC printed circuit boards 1A4A1, 1A4A3, and 1A4A4, parts location diagram (serial numbers 1 through 220), FR-36-039-B-6-31886(E) (sheet 1 of 2)	3-16
3-22(2)	RT-662/GRC (after serial number 220) FR-36-039-B-6-31886(E), and RT-834/GRC printed circuit boards 1A4A1, 1A4A3, and 1A4A4, parts location diagram (sheet 2 of 2)	3-18
3-23(1)	RT-662/GRC printed circuit board 1A4A2, parts location diagram (serial numbers 1 through 220) FR-36-039-B-6-31886(E) (sheet 1 of 2)	3-19
3-23(2)	RT-662/GRC (after serial number 220) FR-36-039-B-6-31886(E), and RT-834/GRC printed circuit board 1A4A2, parts location diagram (sheet 2 of 2)	3-20
3-24	Transmitter and audio module 1A5, parts location	3-21
3-25	Printed circuit boards 1A5A1 and 1A5A3, parts location diagram	3-21
3-26	Printed circuit board 1A5A2, parts location diagram	3-21
3-27	Frequency divider module 1A6, parts location	3-22
3-28	Printed circuit boards 1A6A1 and 1A6A3, parts location diagram	3-23
3-29	Printed circuit board 1A6A2, parts location diagram	3-23
3-30(1)	Receiver IF module 1A7, parts location (sheet 1 of 2)	3-23
3-30(2)	Receiver IF module 1A7, parts location (sheet 2 of 2)	3-24
3-31	Printed circuit boards 1A7A1, 1A7A2, and 1A7A3, parts location diagram	3-25
3-32	Printed circuit board 1A7A4, parts location diagram	3-26
3-33	MHz synthesizer module 1A9, parts location	3-26
3-34	Printed circuit boards 1A9A1, 1A9A4, and 1A9A5, parts location diagram	3-27
3-35	Printed circuit board 1A9A2, parts location diagram	3-27
3-36	Printed circuit board 1A9A3, parts location diagram	3-27
3-37	Receiver audio module 1A10, parts location	3-28
3-38	Printed circuit board 1A10A1, parts location diagram	3-29
3-39	Printed circuit board 1A10A2, parts location diagram	3-29

<i>Figure</i>	<i>Title</i>	<i>Page</i>
3-40	Dc-to-dc converter module 1A11, parts location	3-29
3-41	Printed circuit board 1A11A1, parts location diagram	3-30
3-42	Printed circuit board 1A11A2, parts location diagram	3-30
3-43	Printed circuit board 1A11A3, parts location diagram	3-30
3-44	Printed circuit board 2A4A1, parts location diagram	3-31
3-45	Printed circuit board 2A4A2, parts location diagram	3-31
3-46	Printed circuit board 2A4A3, parts location diagram	3-31
3-47(1)	Relay assembly 2A7, parts location (sheet 1 of 2)	3-32
3-47(2)	Relay assembly 2A7, parts location (sheet 2 of 2)	3-32
3-48	Filament regulator 2A1A2, parts location	3-33
3-49	Filament regulator 2A1A2, terminal location	3-33
3-50	Amplifier, Radio Frequency AM-3349/GRC-106, front panel gear drive assembly, lubrication points	3-55
3-51	Amplifier, Radio Frequency AM-3349/GRC-106, antenna coupler assembly 2A3, lubrication points	3-56
3-52	Amplifier Radio Frequency AM-3349/GRC-106, turret assembly 2A2 switch decks	3-57
3-53	Radio Set AN/GRC-106(*) power output adjustment, test setup	3-61
3-54	Variable Capacitor 2A3C27 programing configuration	3-63
3-55	Frequency accuracy and vernier tuning tests, connection diagram	3-67
3-56	Audio power circuit and overall gain tests, connection diagram	3-69
3-57	Audio distortion tests, connection diagram	3-71
3-58	Vox operation tests, connection diagram	3-73
3-59	Squelch tests, connection diagram	3-75
3-60	Age tests, connection diagram	3-76
3-61	Receiver frequency response tests, connection diagram	3-78
3-62	Frequency response curve	3-79
3-63	BFO tests connection diagram	3-80
3-64	Signal level meter tests, connection diagram	3-81
3-65	Antenna transfer tests, connection diagram	3-83
3-66	High voltage reset circuit tests, connection diagram	3-84
3-67	Testing of Amplifier, Radio Frequency AM-3349/GRC-106 code inputs to antenna coupler assembly, connection diagram	3-88
3-68	Amplifier, Radio Frequency AM-3349/GRC-106, front panel assembly tests, connection diagram	3-95
3-69	Radio Set AN/GRC-106(*), system tests connection diagram	3-102
3-70	Intermodulation bridge, schematic diagram	3-102
3-71	Oscilloscope presentation, AN/GRC-106(*) radio set system tests	3-102
4-1	100 kHz synthesizer module 1A2, performance test setup	4-4
4-2	Frequency standard module 1A3, performance test setup	4-7
4-3(1)	Module testing, waveform diagrams (sheet 1 of 2)	4-8
4-3(2)	Module testing waveform diagrams (sheet 2 of 2)	4-9
4-4	10 and 1 kHz Synthesizer Module 1A4, performance test setup	4-12
4-5	Transmitter IF and audio module 1A5, performance test setup	4-17
4-6	Frequency dividers module 1A6, performance test setup	4-20
4-7	Receiver IF Module 1A7, performance test setup	4-24
4-8	MHz synthesizer module 1A9, performance test setup	4-27
4-9	Receiver audio module 1A10, performance test setup	4-30
4-10	Dc-to-dc converter and regulator module 1A11, performance test setup	4-32
4-11	Antenna coupler assembly 2A3, control positioning	4-35
4-12	Discriminator assembly 2A4, performance test setup	4-38
4-13	AM-3349/GRC-106 front panel assembly 2A5, performance test setup	4-45
4-14	Dc-to-ac inverter Assembly 2A6A1, performance test setup	4-47
4-15	Relay control assembly 2A7, performance test setup	4-48
4-16	AM-3349/GRC-106 driver assembly 2A8, schematic diagram	4-49
4-17	AM-3349/GRC-106, stator assembly 2A9, schematic diagram	4-49
4-18	Antenna coupler assembly 2A3, cam and cam follower detail	4-50
4-19	Antenna coupler assembly 2A3, parts location, C26 removed	4-51
4-20	Resistors, inductors, and capacitors, color code charts	4-53
4-21	Amplifier, Radio Frequency AM-3349/GRC-106, functional block diagram	4-55
4-22	Antenna coupler assembly 2A3, tuning controls	4-57
4-23	Level control signals, interunit circuit details	4-59
4-24	Power control, interunit circuit details, AN/GRC-106(*)	4-61

<i>Figure</i>	<i>Title</i>	<i>Page</i>
4-25	Keying interunit circuit details for AN/GRC-106(*)	4-63
4-26	Tuning interunit circuit details for AN/GRC-106(*)	4-65
4-27	Amplifier, Radio Frequency AM-3349/GRC-106, turret assembly parts location	4-67
4-28	Receiver-Transmitter, Radio RT-662/GRC and RT-834/GRC, waveform diagram	4-69
4-29	RF Amplifier Module 1A12, exploded view parts location diagram	4-71
4-30	RT-662/GRC (serial numbers 1 through 220) FR-36-039-B-6-31886(E) noise blanker assembly 1A1A6, schematic diagram	4-73
4-31	Receiver-Transmitter, Radio RT-662/GRC and RT-834/GRC internal Alc assembly 1A1A2A5, schematic diagram	4-75
4-32	Receiver-Transmitter, Radio RT-662/GRC and RT-834/GRC, front end protection circuit 1A1A1A10, schematic diagram	4-77
4-33	Receiver-Transmitter, Radio RT-662/GRC front panel and chassis 1A1, schematic diagram	4-79
4-34	Receiver-Transmitter, Radio RT-834/GRC, front panel and chassis 1A1, schematic diagram	4-81
4-35	Receiver-Transmitter, Radio RT-662/GRC and RT-834/GRC, 100 kHz synthesizer module 1A2, schematic diagram	4-83
4-36	Receiver-Transmitter, Radio RT-662/GRC, RT-834/GRC frequency standard module 1A3, schematic diagram	4-85
4-37	Receiver-Transmitter, Radio RT-662/GRC (Serial Numbers 1 through 220, Order No. FR-36-039-B-6-31886(E)) 10 and 1 kHz Synthesizer Module 1A4, schematic diagram	4-87
4-38	Receiver-Transmitter, Radio RT-662/GRC (serial number 221 and upward) Order No. FR-36-039-B-6-31886(E) and RT-834/GRC, 10 and 1 kHz synthesizer module 1A4, schematic diagram	4-89
4-39	Receiver-Transmitter, Radio RT-662/GRC and RT-834/GRC, transmitter IF and audio module 1A5, schematic diagram	4-91
4-40	Receiver-Transmitter, Radio RT-662/GRC and RT-834/GRC, frequency divider module 1A6, schematic diagram	4-93
4-41	Receiver-Transmitter, Radio RT-662/GRC and RT-834/GRC, receiver IF module 1A7, schematic diagram	4-95
4-42	Receiver-Transmitter, Radio RT-662/GRC and RT-834/GRC, translator module 1A8, schematic diagram	4-97
4-43	Receiver-Transmitter, Radio RT-662/GRC and RT-834/GRC, MHz synthesizer modulator 1A9, schematic diagram	4-99
4-44	Receiver-Transmitter, Radio RT-662/GRC and RT-834/GRC, receiver audio module 1A10, schematic diagram	4-101
4-45	Receiver-Transmitter, Radio RT-662/GRC and RT-834/GRC, dc-to-dc converter and regulator module 1A11, schematic diagram	4-103
4-46	Receiver-Transmitter, Radio RT-662/GRC and RT-834/GRC, RF amplifier module 1A12, schematic diagram	4-105
4-47	Receiver-Transmitter, Radio RT-834/GRC, 100 Hz Module 1A1A2A8, schematic diagram	4-107
4-48	Receiver-Transmitter, Radio RT-834/GRC, voltage regulator 1A1A2A9, schematic diagram	4-109
4-49	Amplifier-Radio Frequency, AM-3349/GRC-106, chassis assembly 2A1, blower protection 2A1A2A1, and filament regulator 2A1A1A2 tune APC 2A1A1A1, schematic diagram	4-111
4-50	Amplifier-Radio Frequency AM-3349/GRC-106, turret assembly 2A2, schematic diagram	4-113
4-51	Amplifier-Radio Frequency AM-3349/GRC-106, antenna coupler 2A3, schematic diagram	4-115
4-52	Amplifier-Radio Frequency AM-3349/GRC-106, discriminator assembly 2A4, schematic diagram	4-116
4-53	Amplifier-Radio Frequency AM-3349/GRC-106, front panel 2A5, schematic diagram	4-117
4-54	Amplifier-Radio Frequency AM-3349/GRC-106, case assembly 2A6, schematic diagram	4-119
4-55	Amplifier-Radio Frequency AM-3349/GRC-106, relay assembly 2A7, schematic diagram	4-121
4-56(1)	Radio Set AN/GRC-106(*), RT-662/GRC or RT-834/GRC, interconnecting diagram (sheet 1 of 2)	4-123

<i>Figure</i>	<i>Title</i>	<i>Page</i>
4-56(2)	Radio Set AN/GRC-106(*), RT-662/GRC or RT-834/GRC, interconnecting diagram (sheet 2 of 2) -----	4-125
4-57(1)	Radio Set AN/GRC-106(*), AM-3349/GRC-106 interconnecting diagram (sheet 1 of 2) -----	4-127
4-57(2)	Radio Set AN/GRC-106(*), AM-3349/GRC-106 interconnecting diagram (sheet 2 of 2) -----	4-129

LIST OF TABLES

<i>Table</i>	<i>Title</i>	<i>Page</i>
1-1	10 and 1 kHz module test points -----	1-44
1-2	10 and 1 kHz module output frequencies -----	1-44
1-3	System keying for TR Line 3 -----	1-50
1-4	Turret position and code pattern for each frequency band -----	1-71
2-1	Equipment required for direct support troubleshooting -----	2-6
2-2	Receiver-transmitter, Radio RT-662/GRC and RT-834/GRC, test point information -----	2-7
2-3	Amplifier, Radio Frequency AM-3349/GRC-106, test point information -----	2-9
2-4	Troubleshooting RT-662/GRC or RT-834/GRC -----	2-14
2-5	Troubleshooting 100 Hz synthesis, RT-834/GRC -----	2-36
2-6	Troubleshooting AM-3349/GRC-106 -----	2-39
2-7	AM-3349/GRC-106 tube voltage and resistance measurements -----	2-52
2-8	AM-3349/GRC-106 transistor voltage measurements -----	2-53
2-9	AM-3349/GRC-106 terminal voltage measurements -----	2-55
2-10	AM-3349/GRC-106 filter and capacitor programing -----	2-57
2-11	Items requiring direct support inspection -----	2-88
2-12	Switches and controls settings -----	2-89
3-1	Test equipment required for general support maintenance -----	3-1
3-2	Front end protection circuit 1A1A1A10, transistor dc voltage measurements -----	3-3
3-3	Front end protection circuit 1A1A1A10, E-terminal voltage measurements -----	3-3
3-4	Internal Alc assembly 1A1A2A5, E-terminal voltage measurements -----	3-4
3-5	100 Hz module 1A1A2A8, transistor dc voltage measurements -----	3-4
3-6	100 Hz Module 1A1A2A8, E-terminal voltage measurements -----	3-4
3-7	100 Hz module 1A1A2A8, code switch voltage measurements -----	3-5
3-8	Voltage regulator 1A1A2A9, transistor dc voltage measurements -----	3-5
3-9	Voltage regulator 1A1A2A9, E-terminal voltage measurements -----	3-5
3-10	100 kHz synthesizer module 1A2, transistor dc voltage measurements -----	3-5
3-11	100 kHz synthesizer module 1A2, E-terminal voltage measurements -----	3-6
3-12	Frequency standard module 1A3, transistor dc voltage measurements -----	3-8
3-13	Frequency standard module 1A3, E-terminal voltage measurements -----	3-8
3-14	Oven assembly 1A3A1, transistor dc voltage measurements -----	3-10
3-15	Oven assembly 1A3A1, transistor ac voltage measurements -----	3-10
3-16	Oven assembly 1A3A1, E-Terminal voltage measurements -----	3-11
3-17	10 and 1 kHz synthesizer module 1A4, transistor dc voltage measurements -----	3-13
3-18	10 and 1 kHz synthesizer module 1A4, E-terminal voltage measurements -----	3-14
3-19	Transmitter IF and audio module 1A5, transistor dc voltage measurements -----	3-14
3-20	Transmitter IF and audio module 1A5, E-terminal voltage measurements -----	3-15
3-21	Frequency dividers module 1A6, transistor dc voltage measurements -----	3-16
3-22	Frequency dividers module 1A6, E-terminal voltage measurements -----	3-17
3-23	Receiver IF and audio module 1A7, transistor dc voltage measurements -----	3-18
3-24	Receiver IF and audio module 1A7, E-terminal voltage measurements -----	3-18
3-25	MHz synthesizer module 1A9, transistor dc voltage measurements -----	3-19
3-26	MHz synthesizer module 1A9, E-terminal voltage measurements -----	3-19
3-27	Receiver audio module 1A10, transistor dc voltage measurements -----	3-22
3-28	Receiver audio module 1A10, E-terminal voltage measurements -----	3-24
3-29	Dc-to-dc converter 1A11, transistor dc voltage measurements -----	3-24
3-30	Dc-to-dc converter 1A11, E-terminal voltage measurements -----	3-24
3-31	Printed circuit board 2A4, transistor dc voltage measurements -----	3-25
3-32	Printed circuit board 2A4, E-terminal voltage measurements -----	3-25
3-33	Filament regulator 2A1A2, transistor dc voltage measurements -----	3-26
3-34	Filament regulator 2A1A2, E-terminal voltages -----	3-26
3-35	Preliminary test equipment control settings -----	3-59
3-36	Power output adjustment, control settings -----	3-61
3-37	MHz and kHz control settings for automatic programing test -----	3-64

<i>Table</i>	<i>Title</i>	<i>Page</i>
3-38	Frequency accuracy and vernier tuning tests -----	3-64
3-39	Audio power circuit and overall gain test -----	3-67
3-40	Audio distortion test -----	3-69
3-41	Vox operation, RF power output, transmit audio, and transmit AGC test -----	3-71
3-42	Squelch test -----	3-74
3-43	AGC test -----	3-75
3-44	Receiver frequency response and IF bandwidth test -----	3-76
3-45	BFO test -----	3-79
3-46	Signal level meter test -----	3-80
3-47	Antenna transfer test -----	3-82
3-48	High voltage reset circuit test -----	3-83
3-49	RT-834/GRC or RT-662/GRC Programing test -----	3-84
3-50	Receiver-transmitter RT-834/GRC or RT-662/GRC code sequences -----	3-86
3-51	AM-3349/GRC-106 code inputs to antenna coupler assembly 2A3 test -----	3-86
3-52	AM-3349/GRC-106 coding sequence test -----	3-88
3-53	AM-3349/GRC-106 front panel assembly tests -----	3-89
3-54	Switch position and lamp sequence for code line check -----	3-96
3-55	System performance test -----	3-96
4-1	100 kHz synthesizer module 1A2, proof of performance tests -----	4-2
4-2	Frequency standard module 1A3, proof of performance tests -----	4-4
4-3	10 and 1 kHz synthesizer module 1A4 (RT-664/GRC), proof of performance tests -----	4-9
4-4	Transmitter IF and audio module 1A5, proof of performance tests -----	4-12
4-5	Frequency dividers module 1A6, proof of performance tests -----	4-18
4-6	Receiver IF module 1A7, proof of performance tests -----	4-21
4-7	MHz synthesizer module 1A9, proof of performance tests -----	4-25
4-8	Receiver audio module 1A10, proof of performance tests -----	4-28
4-9	Dc-to-dc converter and regulator module 1A11, proof of performance tests -----	4-30
4-10	10 and 1 kHz synthesizer module 1A4 (RT-834/GRC), proof of performance tests -----	4-32
4-11	100 Hz synthesizer module 1A1A2A8, proof of performance tests -----	4-33
4-12	Antenna coupler assembly 2A3, proof of performance tests -----	4-34
4-13	Antenna coupler coding, proof of performance tests -----	4-35
4-14	Discriminator assembly 2A4, proof of performance tests -----	4-36
4-15	Front panel assembly 2A5, proof of performance tests -----	4-39
4-16	Switch position and lamp sequence, code line check -----	4-45
4-17	Dc-to-ac inverter assembly 2A6A1, proof of performance tests -----	4-46
4-18	Relay control assembly 2A7, proof of performance tests -----	4-48

CHAPTER 1

FUNCTIONAL ANALYSIS

Section I. GENERAL

1-1. Scope and Indexes of Publications

a. Scope. This manual contains instructions covering direct support (chap. 2) and general support (chap. 3 and 4) maintenance for Radio Sets AN/GRC-106 and AN/GRC-106A. It includes instructions for troubleshooting, testing, aligning, and repairing the equipment. It also lists tools, materials, and test equipment to perform the maintenance of the equipment. Operation and organizational maintenance are covered in TM 11-5820-520-12.

b. Indexes of Publications.

(1) *DA Pam 310-4.* Refer to the latest issue of DA Pam 310-4 to determine whether there are new editions, changes, or additional publications pertaining to the equipment.

(2) *DA Pam 310-7.* Refer to the latest issue of DA Pam 310-7 to determine whether there are modification work orders (MWO's) pertaining to the equipment.

1-2. Maintenance Records and Reporting of Errors

a. Maintenance Records. Use equipment forms and records in accordance with instructions given in TM 38-750.

b. Reporting of Equipment Publication Improvements. The reporting of errors, omissions, and recommendations for improving this publication by the individual user is encouraged. Reports should be submitted on DA Form 2028 (Recommended Changes to Publications) and forwarded direct to Commanding General, US Army Electronics Command, ATTN: AMSEL-MA-CR, Fort Monmouth, N. J., 07708.

NOTE

For other applicable forms and records, see paragraph 1-3, TM 11-5820-520-12.

Section II. BLOCK DIAGRAM ANALYSIS OF RECEIVER-TRANSMITTER, RADIO RT-662/GRC AND RT-834/GRC

1-3. Transmit Operation, Functional Description (fig. 1-1)

NOTE

The IF and injection frequencies used in the following discussion are applicable to the RT-662/GRC only. Refer to section V (para 1-22 through 1-24) for the RT-834/GRC frequency synthesis.

a. During transmit operation, the audio input from the minor electrical component or radio teletypewriter terminal equipment is applied to the audio portion of transmitter intermediate frequency (IF) and audio module 1A5. (Paragraph 2-5*a* describes the use of reference designations such as 2A5.) In single sideband (ssb), compati-

ble amplitude modulation (compatible am), narrow frequency-shift-keying (nsk), or frequency-shift-keying (fsk) operation, the audio input signals are regulated to a constant amplitude and applied to a series of audio amplifiers. In continuous-wave (cw) operation, a 2-kilohertz (kHz) signal is developed from the 1-kHz pulsed input from frequency divider module 1A6 (each time the cw keyline is closed) and applied to the same audio amplifiers. This 2-kHz signal is keyed to provide the intelligence transmitted in cw operation. The audio portion of transmitter IF and audio module 1A5 also provides the voice-operated transmitter (vos) switching and performs the primary keying function.

b. The amplified audio output from the audio portion of transmitter IF and audio module 1A5

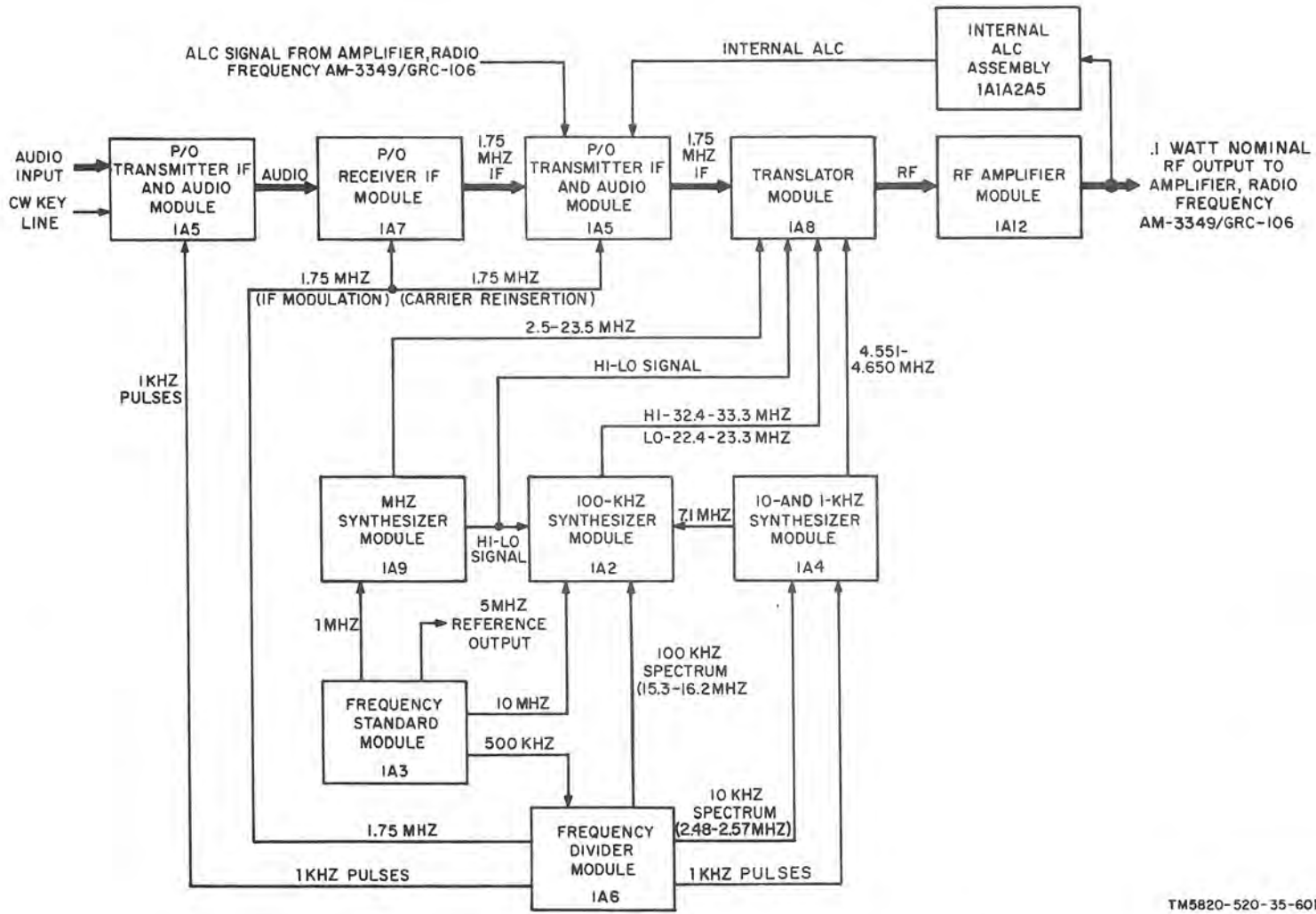

TM5820-520-35-601

Figure 1-1. Receiver-Transmitter Radio RT-662/GRC, transmit operation, functional block diagram.

is applied to the balanced modulator in receiver IF module 1A7. A 1.75 megahertz (MHz) output from frequency divider module 1A6 is also applied to the balanced modulator. Mixing these two inputs in the balanced modulator produces a modulated 1.75 MHz double-sideband, suppressed-carrier IF output. This output passes through a crystal filter, (part of receiver IF module 1A7) which removes the lower sideband, further attenuates the carrier, and establishes the bandwidth of the upper sideband at 3.2 kHz.

c. The 1.75-MHz upper sideband IF output from the crystal filter receiver IF module 1A7 is applied to the IF portion of transmitter IF and audio module 1A5 and to the receiver IF circuits. During cw transmission, the receive IF circuits are energized (para 1-4c) to allow the transmit IF signal to be demodulated and applied to receiver audio module 1A10. This provides a sidetone for monitoring cw transmissions. The IF portion of transmitter IF and audio module 1A5 provides the necessary IF amplification. The amplification stages are controlled by automatic level control (alc) signals that are developed from a modulated direct current (dc) control voltage from Amplifier, Radio Frequency AM-3349/GRC-106 or from internal alc assembly 1A1A2A5. The internal alc signal is normally used only when the AM-3349/GRC-106 is not functioning. The internal alc is always present, but the normal control from the AM-3349/GRC-106 sets the radio frequency (rf) output level below the internal alc threshold. In compatible am operation, the 1.75 MHz local carrier is reinserted into the signal path in the IF portion of transmitter IF and audio module 1A5. The level of the reinserted carrier is controlled by the average power control (apc) portion of the signal applied from the AM-3349/GRC-106 (para 1-6f). The modulation portion of the compatible am signal is controlled by the peak-power control (ppc) portion of the signal applied from the AM-3349/GRC-106 (para 1-6g).

d. The amplified 1.75 MHz IF upper sideband output from the IF portion of transmitter IF and audio module 1A5 is applied to a low-frequency (1f) mixer in translator module 1A8 (para 1-7). Translator module 1A8 converts the 1.75 MHz IF signal into the selected operating rf. This is accomplished through a series of mixing processes. In the 1f mixer, the 1.75 MHz IF is subtractively mixed with one of the injection frequencies (4.551 to 4.650 MHz) from 10 and 1 kHz synthesizer module 1A4 to produce a second 2.8 to 2.9 MHz IF signal. This signal is applied

to a medium-frequency (mf) mixer and subtractively mixed with one of the hi (32.4 to 33.3 MHz) or lo (22.4 to 23.3 MHz) injection frequencies from 100 kHz synthesizer module 1A2. This mixing produces a third IF between 19.5 and 20.5 MHz (hi). The use of either the hi or lo injection is determined by the settings of the receiver-transmitter front panel frequency controls (para 1-20). The hi/lo signal from MHz synthesizer module 1A9 also controls the selection of appropriate filters. The high or low third IF signal is applied to a high-frequency (hf) mixer and is mixed with one of the injection frequencies (2.5 to 23.5 MHz) from MHz synthesizer module 1A9.

e. The rf output products from translator module 1A8 are applied to rf amplifier module 1A12. This module consists of two vacuum-tube stages of amplification with highly selective tuned input and output circuits. The transformers and a portion of the capacitance required by these input and output circuits are contained on a motor-driven turret that is activated by the front panel frequency controls (para 1-26). Disks, holding fixed capacitors that supply the remaining capacitance required in the tuned input and output circuits at a given frequency, are mechanically positioned by the 100 kHz and 10 kHz digital controls. The highly selective tuner input and output circuits reject unwanted signals and all harmonic outputs from translator module 1A8, except the one that represents the exact setting of the MHz and kHz controls. This rf signal is amplified to a nominal 0.1 watt peak envelope power (pep.) output and applied directly through the rf output relay and internal ALC assembly 1A1A2A5 to Amplifier, Radio Frequency AM-3349/GRC-106.

f. The generation of the mixing frequencies for translator module 1A8 is accomplished indirectly by frequency standard module 1A3, frequency divider module 1A6, and 100 Hz synthesizer and directly by MHz synthesizer module 1A9, 100 kHz synthesizer module 1A2, and 10 and 1 kHz synthesizer module 1A4. Frequency standard module 1A3 produces an accurate and stable 5 MHz reference frequency to which all other frequencies used in receiver-transmitter, are synchronized. Frequency standard module 1A3 produces four outputs: 500 kHz, 1 MHz, 5 MHz, and 10 MHz. The 500 kHz output is applied to Frequency divider module 1A6 to develop four additional output signals as follows: 1.75 MHz for modulation in all modes of operation and local carrier reinsertion in compatible am op-

eration; a 1 kHz pulsed output for use in transmitter IF and audio module 1A5 (*a* above), 10 and 1 kHz synthesizer module 1A4, and 100 Hz synthesizer in the RT-834/GRC only; a 2.48 MHz to 2.57 MHz (10 kHz) spectrum for use in 10 and 1 kHz synthesizer module 1A4; and a 15.3 to 16.2 MHz (100 kHz) spectrum for use in 100 kHz synthesizer module 1A2. The 1 MHz output from frequency standard module 1A3 is applied to MHz synthesizer module 1A9 to lock its output at the required frequency. The 5 MHz output is available at the front panel for reference of external use. The 10 MHz output is applied to 100 kHz synthesizer module 1A2. The 10 and 1 kHz synthesizer module, 1A4, produces two outputs as follows: a 4.551 to 4.650 MHz mixing frequency (output determined by setting the 10 kHz and 1 kHz controls) for use in translator module 1A8 (*d* above); and a 7.1 MHz (7.089 MHz RT-834/GRC) signal for use in 100 kHz synthesizer module. The 100 kHz synthesizer module 1A2, the 7.1 MHz signal from 10 and 1 kHz synthesizer module 1A4, the 10 MHz output from frequency standard module 1A3, and the 100 kHz spectrum output from frequency dividers module 1A6, are mixed with the output from an oscillator the frequency of which is determined by the setting of 100 kHz control. This mixing produces two bands of frequencies for use in translator module 1A8 (*d* above). The selection of either the hi or lo band is determined by the hi/lo signal from MHz synthesizer module 1A9. This hi/lo signal is also applied to translator module 1A8 (*d* above). MHz synthesizer module 1A9 also produces a band of mixing frequencies for use in translator module 1A8 (*d* above).

1-4. Receive Operation, Functional Description (fig. 1-2)

NOTE

The IF and injection frequencies used in the following discussion are applicable to the RT-662/GRC only. Refer to section V (para. 1-22 through 1-24) for the RT-834/GRC frequency synthesis.

a. The receive rf signal is applied to rf Amplifier module 1A12. The same rf amplifier module 1A12 circuits used in transmit operation (para 1-3*e*) are used in receive operation. The two tuned amplifier stages are used to raise the level of the incoming rf signal and provide the selec-

tivity required to reduce adjacent channel interference, increase image rejection, and prevent cross-modulation. Manual and automatic gain control of the amplifiers is provided by Receiver IF module 1A7.

b. The amplifier rf output from rf amplifier module 1A12 is applied to translator module 1A8, where it is converted to a 1.75 MHz IF signal by triple conversion. This conversion is essentially the same as that described in paragraph 1-3*d*, except that the sequence is reversed. The input is applied to the high frequency (hf) mixer, the medium frequency (mf) mixer, and finally to the low frequency (lf) mixer. The mixing frequencies used are developed in MHz Synthesizer module 1A9, 100 kHz synthesizer module 1A2 and 10 and 1 kHz synthesizer module 1A4, respectively. The result of the final mixing is the 1.75 MHz IF upper-sideband signal.

c. The 1.75 MHz IF signal is applied to the same crystal filter in Receiver IF module 1A7 that is used during transmit operation. The input to the filter is determined by diode switching circuits. The filter is used to establish the desired 3.2 kHz bandwidth for the IF signal. An automatic gain control (agc) voltage is developed in receiver IF module 1A7 and is applied to rf amplifier module 1A12. The agc is also used within receiver IF module 1A7 to control the gain of the receiver IF amplifier stages. A locked (to the 5 MHz frequency standard) 1.75 MHz local carrier from frequency dividers module 1A6 or the variable beat-frequency oscillator (bfo) signal (generated in receiver IF module 1A7) is used to demodulate the 1.75 MHz upper sideband IF signal. The use of the variable bfo signal allows the operator to vary the tone 3.5 kHz during cw operation. The demodulated audio information is then amplified in Receiver Audio module 1A10. During cw transmit operation, receiver IF and receiver audio modules (1A7 and 1A10) are energized (para 1-3*c*) to provide a sidetone to monitor the cw keying.

d. The output from receiver IF module 1A7 is applied through the AUDIO GAIN control to receiver audio module 1A10 where it is amplified and applied to the front panel AUDIO connectors. A squelch circuit is provided in receiver audio module 1A10 to squelch background noise in the absence of voice during ssb or compatible am operation. Receiver audio module 1A10 provides two outputs: 2 watts for driving dynamic Loudspeaker LS-166/U, and 10 milliwatts for Headset H-227/U or Handset H-33(*)/PT use.

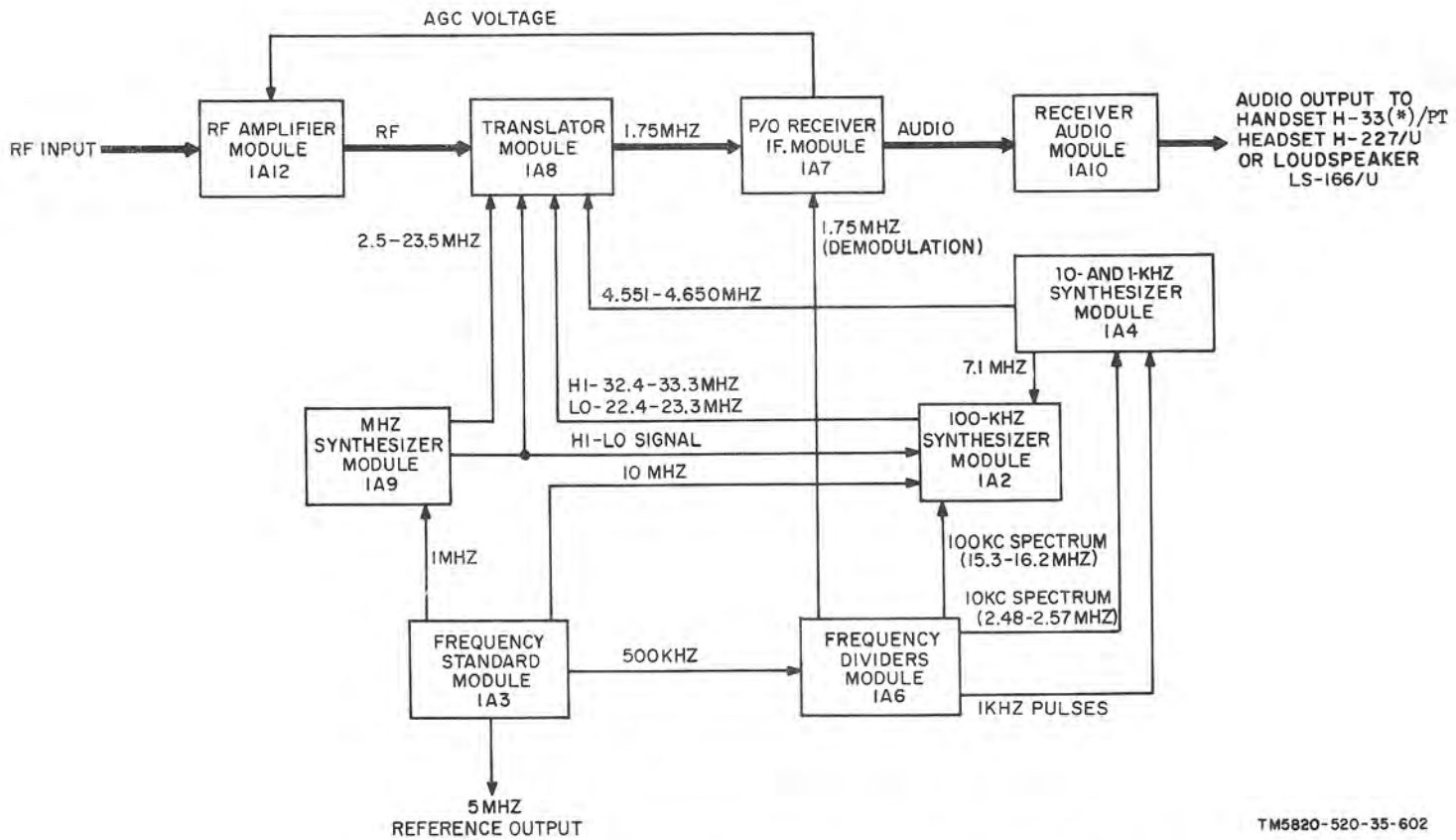

TM5820-520-35-602

Figure 1-2. Receiver-Transmitter Radio RT-662/GRC, receive operation, functional block diagram.

e. Frequency generation (para 1-3f) is accomplished during receiver operation in the same manner as the transmit operation, with the following exceptions: the mixing processes are re-

versed; the 1.75 MHz output from frequency divider module 1A6 is used for demodulation; the vernier operation is available.

Section III. TRANSMIT SECTION CIRCUIT ANALYSIS, RECEIVER-TRANSMITTER, RADIO RT-662/GRC AND RT-834/GRC

1-5. General

The transmitter section of either RT-662/GRC or RT-834/GRC is used to impose the audio intelligence applied through the AUDIO connectors on one of 28,000 or 280,000 rf operating frequencies respectively in the 2.0 to 29.999 MHz frequency range for either an ssb, fsk, nsk, cw, or compatible am mode of operation. The rf power output from the transmitter is a nominal 0.1 watt and is used to drive Amplifier, Radio Frequency AM-3349/GRC-106. Front Panel and Chassis 1A1 Schematic Diagrams are provided in figure 4-33 for the RT-662/GRC, and figure 4-34 for the RT-834/GRC. Individual module and assembly schematic diagrams are referenced where applicable.

1-6. Transmitter IF and Audio Module 1A5

(fig. 4-39)

a. *General.* The function of transmitter IF and audio module 1A5 is to regulate the audio intelligence to a constant level for application to the balanced modulator (para 1-12f); perform the primary transmitter keying; produce the 2 kHz injection for cw operation; provide the vox capability; and to provide the controlled IF amplification. The IF amplification is controlled by a dc voltage generated in the AM-3349/GRC-106, that is proportional to rf output power level.

NOTE

Prefix all reference designators used in this paragraph with transmitter IF and audio reference designator 1A5, unless otherwise specified.

b. *Audio Amplification.* The audio amplification circuits are discussed below.

(1) The audio intelligence is applied to either pin 17 or pin 16 of connector J1 (A2, fig. 4-39). Pin 17 is the input for carbon microphones, and pin 16 is the input for dynamic microphones. Resistor A2R1 is used to connect the required dc bias to the carbon microphones. Ca-

pacitor A2C1 is used to block the microphone bias from being applied to transmit audio attenuator A2Q1. Resistors A2R2 and A2R5 provide a voltage divider to reduce the higher input levels from the carbon microphones to one near that of the dynamic microphones. Resistor A2R5 also provides the 50-ohm termination for the carbon microphones. Resistor A2R4 provides the 600-ohm termination for the dynamic microphones.

(2) Resistor A2R6 and transmit audio attenuator A2Q1 form a variable voltage divider to maintain the level of audio at the base of audio frequency (af) amplifier A2Q2 at a nearly constant level. The attenuation effect of the voltage divider is varied by varying the collector-to-emitter resistance of transmit audio attenuator A2Q1. This resistance is varied by the agc loop, which changes the dc voltage at the base of transmit audio attenuator A2Q1 as the signal level changes ((4) below). The output from the voltage divider is coupled by capacitor A2C7 to the base of af amplifier A2Q2. Resistor A2R7 isolates the voltage divider from the input impedance of af amplifier A2Q2 in order that maximum control range can be obtained from transmit audio attenuator A2Q1.

(3) Af amplifier A2Q2 amplifies the audio and develops it across resistor A2R25. Resistor A2R24 is used to provide collector-to-base feedback to improve the stability and minimize the distortion of af amplifier A2Q2, and is also part of the base-bias voltage divider. The output from af amplifier A2Q2 is direct-coupled to the base of af amplifier A2Q3. Af amplifier A2Q3 further amplifies the audio intelligence and develops it across voltage divider A2R31, A2R32. Resistor A2R30 provides collector base-to-feedback to improve the stability and minimize the distortion of af amplifier A2Q3. The output from voltage divider A2R31, A2R32 is applied through capacitor A2C18 to pin 19 of connector J1 for application to the balanced modulator (para 1-12f). The output from the collector of af amplifier A2Q3 is direct-coupled to the base of af amplifier A2Q4.

(4) Af amplifiers A2Q4, A2Q5 provide a point for sampling the audio signal to develop the agc and also provide isolation between the agc loop (A2CR2 through A2CR5, A2Q6, A2Q1) and the af amplifiers (A2Q2, A2Q3) to prevent distortion from the full-wave rectifier circuit from feeding back into af amplifier A2Q3. The amplified output from the collectors of af amplifier A2Q4 and A2Q5 is developed across the primary of transformer A2T1. The output from af amplifier A2Q5, which is developed across the unbypassed portion of the emitter load (resistor A2R28), is coupled by capacitors A2C33 and A2C16 to the base of af amplifier A2Q8 (*b* below). Transformer A2T1 couples the output from af amplifiers A2Q4 and A2Q5 to a full-wave rectifier circuit consisting of diodes A2CR2 through A2CR5. The resulting dc voltage is filtered by capacitor A2C5 and applied to the base of agc dc amplifier A2Q6. Resistors A2R21 and A2R20 and thermistor A2R54 form a temperature-compensated load for transformer A2T1 to maintain the input to the full-wave rectifier at a nearly constant level, regardless of variations in temperature. Agc dc amplifier A2Q6 raises the level of the dc signal. The output from agc dc amplifier A2Q6 is filtered by capacitor A2C4 and is applied to the base of transmit audio attenuator A2Q1. As the audio input level at the AUDIO connectors increases, the output from agc dc amplifier A2Q6 increases, decreasing the collector-to-emitter resistance of transmit audio attenuator A2Q1. Similarly, as the audio input level at the AUDIO connectors decreases, the collector-to-emitter resistance of transmit audio attenuator A2Q1 increases. Therefore, this variable shunt resistance maintains the audio output from af amplifier A2Q3 at a nearly constant level, regardless of the fluctuations of input level at the AUDIO connectors.

(5) During cw operation, 20 volts dc is applied to pin 13 of connector J1. This voltage is applied to the center tap on the secondary of transformer A2T1, heavily forward-biasing diodes A2CR2 and A2CR3; thus, biasing agc dc amplifier A2Q6 into saturation. This, in turn, biases transmit audio attenuator A2Q1 into saturation. Therefore, the variable voltage divider will provide maximum attenuation to any inputs from the microphones, thereby minimizing leakage into af amplifiers A2Q2 and A2Q3.

c. 2 kHz Generator. The 2 kHz generator consists of 1 kHz pulse switch A2Q12, a filter, and cw 2 kHz switch A2Q7. These circuits are used to develop the 2 kHz tone used for cw keying.

The 2 kHz tone is developed from the 1 kHz pulse output from Frequency Dividers module 1A6.

(1) The 1 kHz pulse output from Frequency Dividers module 1A6 (para 1-16) (fig. 4-40) is applied to connector J1A4 on 1A5A2. In the absence of ground at pin 30 of connector J1, the 20 volts dc causes 3.3 volt Zener diode A2VR1 to fire, forward-biasing 1 kHz pulse switch A2Q12. Since 1 kHz pulse switch A2Q12 is conducting, except when the KY-166/U key is depressed (ground on pin 30 of connector J1), the 1 kHz pulse input will be attenuated by the small collector-to-emitter resistance of 1 kHz pulse switch A2Q12. When the KY-116/U key is depressed, ground is applied to pin 30 of connector P1. This ground is applied to the cathode of diode A2CR20, causing it to conduct and reduce the 20 volt dc supply voltage below the firing point 3.3 volt Zener diode A2VR1. Therefore, when the KY-116/U key is depressed, 1 kHz pulse switch A2Q12 becomes nonconducting and the 1 kHz pulse input will be allowed to pass to the triple section filter.

(2) The triple section filter is tuned to pass only the second harmonic of the 1 kHz pulse input. This 2 kHz signal is applied to the base of cw 2 kHz switch A2Q7. During cw operation, the SERVICE SELECTOR switch (para 1-23) applies a ground to pin 14 of connector J1. The ground is applied to the cathode of diode A2CR6, completing the emitter circuit for cw 2 kHz switch A2Q7. Cw 2 kHz switch A2Q7 amplifies the 2 kHz signal and develops the resulting output across collector load resistor A2R27. Resistor A2R8 is used to provide collector-to-base feedback to improve the stability and minimize the distortion of cw 2 kHz switch A2Q7 as well as being the base-bias resistor. A small amount of degeneration is provided by the unbypassed small forward resistance of diode A2CR6 to improve the stability of 2 kHz switch A2Q7. The output from cw 2 kHz switch A2Q7 is coupled by capacitor A2C7 to the base of rf amplifier A2Q2. Capacitor A2C2 and resistors A2R15 and A2R16 form an equalizing network to keep the 2 kHz tone at the same level as the voice input.

d. Keying. The keying circuit consists of af amplifier A2Q8, vox detector A2Q9, vox switch A2Q10, transmit-receive switch A2Q11, transmit-receive switch Q1, and the vox and SERVICE SELECTOR switches. When the radio set is being operated in the ssb or compatible am mode of operation, it can be keyed by three possible methods: PUSH TO VOX, PUSH TO TALK, or VOX, as

determined by the vox switch on the receiver-transmitter front panel. During the cw or fsk modes of operation, the keying is accomplished using the KY-116/U and radio teletypewriter terminal equipment, respectively. During both cw and fsk operation, the vox switch is disabled. Regardless of the methods of keying, the function is initiated in the circuits of transistors A2Q8 through A2Q11 and Q1.

(1) *Vox operation.* The emitter output from af amplifier A2Q5 is amplified by af amplifier A2Q8 and developed across collector load resistor A2R38. Collector-to-base feedback is produced by resistor A2R33 to improve the stability and minimize the distortion of af amplifier A2Q8. The output from af amplifier A2Q8 is coupled by capacitor A2C23 to the base of vox detector A2Q9. The level of the applied signal is set by resistor A2R41, which determines the vox threshold (minimum voice level which will initiate the vox keying function). Capacitor A2C24 is a bypass for frequencies above the range of maximum voice energy (approximately 400-600 hertz (Hz)). In vox operation, a ground is applied through the SERVICE SELECTOR and vox switches on the front panel to pin 27 of connector J1. This ground is applied to the emitter of vox detector A2Q9, removing the reverse bias developed by resistors A2R43 and A2R44. Therefore, the voice input signals above the vox threshold bias vox detector A2Q9 on, causing it to conduct into saturation. This provides a low-impedance discharge path for capacitor A2C25 (through the small collector-to-emitter resistance of vox detector A2Q9) to initiate the vox keying function. Initially, and whenever a voice is not being transmitted, the 27 volts dc, which is regulated to 20 volts dc by Zener diode A2VR3, will forward-bias vox switch A2Q10. Therefore, capacitor A2C25 will begin to charge. As capacitor A2C25 charges, the emitter voltage of vox switch A2Q10 will increase until it is of sufficient level to fire 12 volt Zener diode A2VR4. At this time, slightly less than 13 volts dc is present on both the emitter and base, preventing vox switch A2Q10 from conducting. When 12 volt Zener diode A2VR4 is conducting, transmit-receive switch A2Q11 will be forward-biased, causing the collector voltage to drop and prevent 12 volt Zener diode A2VR5 from firing. Therefore, transmit-receive switch Q1 will be off. This prevents the coils of relays 1A1K1, 1A1K3, 1A1K4, and 1A1K5 (para 1-23) from having a path to ground; therefore, the relays will remain deenergized. When the voice level applied to vox de-

tector A2Q9 exceeds the vox threshold, vox detector A2Q9 is forward-biased by the positive peaks, and conducts. This allows capacitor A2C25 to discharge through the small collector-to-emitter resistance of vox detector A2Q9, forward-biasing vox switch A2Q10. (The emitter has been at approximately 13 volts.) As vox switch A2Q10 conducts, the emitter voltage will drop and prevent Zener diode A2VR4 from firing. This will cut off transmit-receive switch A2Q11, causing the collector voltage to try to approach 20 volts dc and fire 12 volt Zener diode A2VR5. This will forward-bias transmit-receive switch Q1, effectively placing the collector at ground through the small collector-to-emitter resistance. This ground is applied through diode A2CR18 to pin 31 of connector J1, from which it is applied to relays 1A1K1, 1A1K3, 1A1K4, and 1A1K5 to energize them (para 1-23) and place the receiver-transmitter in transmit condition. This ground is also applied to pin 32 of connector J1 for application to the AM-3349/GRC-106 to initiate the keying functions. Zener diode A2VR2 prevents transients produced by deenergizing relays 1A1K1, 1A1K3, 1A1K4, and 1A1K5 from being applied to the collector of transmit-receive switch Q1. The radio set will remain keyed for 500 milliseconds after the completion of the message. This hangtime is provided to prevent pauses in normal speech from repeatedly keying and unkeying the radio set. The hangtime is the time required for capacitor A2C25 to recharge through vox switch A2Q10 to the point where vox switch A2Q10 cuts off.

(2) *Push to vox.* The sequence of operation for push-to-vox operation is the same as that for vox operation, with the following exception: Pin 27 of connector J1 is at ground only when the H-33(*)/PT or M-29B/U push-to-talk switch is depressed, rather than the permanent ground applied during vox operation. Voltage divider A2R43, A2R44 reverse-biases switch A2Q9, preventing the voice from keying the radio set until the push-to-talk switch is depressed. When the push-to-talk switch is released, there is no hangtime (para 1-26).

(3) *Push to talk.* When operating in push to talk, a ground is applied to pin 29 of connector J1 each time the H-33(*)/PT or M-29B/U push-to-talk switch is depressed. This ground is applied to the base of transmit-receive switch A2Q11, turning it off. The voltage on the collector of transmit-receive switch A2Q11 tries to approach 20 volts dc, firing 12 volt Zener diode A2VR5. Therefore transmit-receive switch Q1

will be turned on to initiate the keying functions ((1) above) each time the M-29B/U or H-33(*)/PT push-to-talk switch is depressed.

(4) *Cw and fsk.* When operating in the cw or fsk mode of operation, the front panel vox switch is disabled. The SERVICE SELECTOR switch (para 1-26) applies a ground to pin 22 of connector J1. This ground is applied through diodes A2CR7 and A2CR8 to the base and collector of amplifier A2Q8, cutting it off. This prevents any audio from being applied to vox detector A2Q9. In cw operation, the KY-116/U key places a ground at pin 30 of connector J1 each time the key is depressed. This ground is applied to the base of vox switch A2Q10 through diode A2CR11. Therefore, capacitor A2C25 will discharge through the small forward resistance of diode A2CR11 to turn on vox switch A2Q10. The radio set is then keyed as previously explained. At the termination of the message, the radio set will remain keyed for approximately 500 milliseconds. This hangtime is provided to prevent the radio set from going into receive operation during a normal message pause. In fsk operation, ground is applied to pin 29 of connector J1 by the radio-teletype terminal equipment. The keying is then accomplished in the same way as for push-to-talk operation.

e. IF Amplification. The IF amplification circuit controls and amplifies the output from the ssb crystal filter in receiver IF module 1A7 in order to provide a constant input at the desired level for use in Translator module 1A8 (para 1-7). The IF amplification circuit consists of two IF amplifiers (A1, fig. 4-39), one of which is controlled by the output from the average power control (apc) circuit (*f* below) and the other is controlled by the output from the peak power control (ppc) circuit (*g* below). During compatible am operation, the required 1.75 MHz local carrier is reinserted into the 1.75 MHz IF signal in the second IF (apc controlled) amplifier stage.

(1) The 1.75 MHz IF output from the ssb crystal filter is applied to connector J1A3. From connector J1A3, the 1.75 MHz IF signal is coupled by capacitor A1C3 to a variable voltage divider consisting of resistor A1R3 and the collector-to-emitter and base-to-emitter resistances of ppc attenuator A1Q1. The voltage divider is controlled by the dc output voltage from the ppc circuit (*g* below). This dc voltage is developed across the temperature-compensated voltage divider consisting of resistors A1R1 and A1R2, thermistor A1R33, and diode A1CR1. Capacitor A1C2 places an alternating current (ac) short be-

tween collector and base, causing both the collector-to-emitter resistance and the base-to-emitter resistance to form a part of the total shunt resistance for controlling the level of the IF signal input to transmit IF amplifier A1Q3. Diode A1CR4 provides temperature-compensation bias for ppc attenuator A1Q1. The output from the voltage divider is coupled by capacitor A1C6 to the base of transmit IF amplifier A1Q3.

(2) The gain of transmit IF amplifier A1Q3 is controlled by ppc degenerator A1Q2. Ppc degenerator A1Q2 acts as a variable resistive-degenerative element in series with emitter bypass capacitor A1C7. The base voltage for ppc degenerator A1Q2 is developed from the 20-volt dc supply line by voltage divider A1R6, A1R7, and A1R8 and the collector-to-emitter and collector-to-base resistances of ppc attenuator A1Q1. A decrease in the transmitted rf signal level decreases the ppc voltage level, causing ppc attenuator A1Q1 to conduct less, thus increasing the shunt resistance (less attenuation). This will bias ppc degenerator A1Q2 into saturation, effectively grounding emitter bypass capacitor A1C7. Therefore, the output from transmit IF amplifier A1Q3 is maximum. As the ppc voltage increases, the conduction of ppc attenuator A1Q1 will increase. The amount of conduction will be controlled by the rf output signal level. The shunt resistance will decrease as the rate of conduction increases, decreasing the amount of signal applied to the base of transmit IF amplifier A1Q3. As the rate of conduction of ppc attenuator A1Q1 increases, the dc voltage present at the collector will decrease. Therefore, the base voltage on ppc degenerator A1Q2 will decrease, decreasing its rate of conduction. This will increase the impedance in series with emitter bypass capacitor A1C7, providing increased degeneration to decrease the gain of transmit IF amplifier A1Q3. Ppc attenuator A1Q1 and ppc degenerator A1Q2 together provide greater than 40 dB of control to maintain the peak output from transmit IF amplifier A1Q3 at a nearly constant level, regardless of the output signal level.

(3) The output from transmit IF amplifier A1Q3 is coupled to another voltage divider consisting of resistor A1R20 and the collector-to-emitter and collector-to-base resistance of apc attenuator A1Q4 by capacitor A1C15. The amount of control provided by the variable voltage divider depends on the dc output from the apc circuit (*f* below). The output from the voltage divider is coupled by capacitor A1C19 to the base of transmit IF amplifier A1Q6. The gain of transmit

IF amplifier A1Q6 is determined by the amount of degeneration developed by the collector-to-emitter resistance of apc degenerator A1Q5. The theory of operation for transistor stages A1Q4, A1Q5, and A1Q6 is identical with that for the corresponding stages A1Q1, A1Q2, and A1Q3 ((1) and (2) above). The output from transmit IF amplifier A1Q6 is coupled by transformer A1T2 to connector J1A1 for application to translator module 1A8 (para 1-7).

(4) In ssb, cw, fsk, or nsk mode of operation, pins 9 and 10 of connector J1 will be open. Therefore, the 20-volt dc supply voltage present at pin 1 of connector J1 will be applied through resistor A1R19 to the cathodes of diodes A1CR6 and A1CR7. Since their anodes are at 10 volts dc (developed from the 20 volts dc by voltage divider A1R18, A1R15 and applied through isolating resistors A1R22 and A1R17) they will be reverse-biased. These diodes insure that any 1.75 MHz leakage will be at least 50 dB down from the 1.75 MHz IF signal. During compatible am operation, the 1.75 MHz local carrier is gated back into the IF signal as follows: The 1.75 MHz output from the frequency dividers module is applied to connector J1A2, from which it is applied to AM CARRIER ADJ A1R14. AM CARRIER ADJ A1R14 is used to set the injection level. During compatible am operation, ground is applied to pin 9 of connector J1, from which it is applied through diode A1CR2 to the cathodes of diodes A1CR6 and A1CR7. Since the anodes of diodes A1CR6 and A1CR7 are at 10 volts dc, they will be forward-biased, allowing the 1.75 MHz local carrier to pass and be coupled by capacitor A1C16 into the main signal path at the junction of resistors A1R21 and A1R20. When the radio set is in tune condition, a ground from the AM-3349/GRC-106 is applied at pin 10 of connector J1. The tune ground applied through diode A1CR3 has the same effect as the am ground applied through diode A1CR2. In this case, however, there is no IF input at J1A3.

f. Average Power Control. The apc circuit in this module (A3, fig. 4-39) is used to process the modulated dc output from the AM-3349/GRC-106 before application to the IF amplification circuits. The apc circuit consists of three dc amplifiers, a modulation wiper, and an apc filter circuit.

(1) The input to the apc circuit is the output from the divider network on the chassis assembly. This signal has the positive peaks of the detected signal riding on a dc level. It is applied to pin 7 of connector J1, from which it is applied

to the base of apc dc amplifier A3Q1. Apc dc amplifier A3Q1 isolates the voltage dividing network (on the chassis) from the modulation wiper. Capacitor A3C1 is an rf bypass for any signal that may be present in the signal. The output from apc dc amplifier A3Q1 is applied to the modulation wiper.

(2) The modulation wiper consists of resistors A3R2, A3R3, A3R4, and A3R12, diode A3CR1, and capacitor A3C2. The function of the modulation wiper is to average the peaks of the applied signal, to produce a dc output which is proportional to the average power output from the AM-3349/GRC-106. During compatible am operation, the modulation wiper will level-set the carrier and ignore the presence of modulation. This insures that the power level of the carrier will remain the same, with or without modulation. Capacitor A3C2 charges on the positive going slope of the applied signal, through resistor A3R3. The time constant of resistor A3R3 and capacitor A3C2, in combination with the dividing action of resistors A3R3 and A3R4, is such that capacitor A3C2 charges to the average level of the applied peaks. On the negative-going slope of the applied signal, the voltage of charged capacitor A3C2 will forward-bias diode A3CR1. Therefore, the discharge path will be through diode A3CR1 and the parallel combination of resistors A3R2 and A3R12. (Ground is present at pin 24 of connector J1 during transmit operation.) The discharge time-constant is very short, allowing the capacitor to rapidly discharge as the negative-going slope of the applied signal going toward zero. This insures that the charge created by the next positive-going slope starts near zero, thereby preventing the apc voltage from creeping up and allowing the apc loop to decrease the average power output from the AM-3349/GRC-106.

(3) The voltage of charged capacitor A3C2 is the signal for apc dc amplifier A3Q2. Apc dc amplifier A3Q2 provides isolation between the modulation wiper and the apc filter circuit (resistor A3R5 and capacitors A3C3 and A3C6). As apc dc amplifier A3Q2 is turned on by the dc signal on capacitor A3C2, capacitors A3C3 and A3C6 will rapidly charge through the small collector-to-emitter resistance of apc dc amplifier A3Q2. The discharge path for these capacitors is through resistor A3R5. The resistance-capacitance (rc) time constant of the discharge path is very long compared to the frequency of the applied signal. Therefore, the voltage of charged capacitors A3C3 and A3C6 will be maintained at a

nearly constant level for a given output from the AM-3349/GRC-106. This voltage is used as the dc signal for apc dc amplifier A3Q3.

(4) Apc dc amplifier A3Q3 provides the required isolation between apc attenuator A1Q4 and the apc filter circuit. The output from apc dc amplifier A3Q3 is applied to the base of apc attenuator A1Q4, determining the amount of attenuation for the IF signal applied to IF amplifier A1Q6 (*d* above). This closes the apc loop between the AM-3349/GRC-106 output and the receiver-transmitter input to maintain the average power level of the transmitted signal at a predetermined value.

(5) During receive operation, pin 24 of connector J1 has 20 volts dc applied to it. This 20 volts is divided by resistors A3R12 and A3R2 and is used to charge capacitor A3C2, thus providing an apc output from apc dc amplifier A3Q3. Therefore, when the receiver-transmitter is keyed by the voice input (Vox or push-to-vox operation), there will be apc control for the initial peaks preventing the AM-3349/GRC-106 from being overdriven. Once keyed, ground is applied to pin 24 of connector J1, providing a discharge path for capacitor A3C2. The circuit will then be controlled according to the average power output from the AM-3349/GRC-106 as previously explained ((1) through (4) above).

(6) When the receiver-transmitter is operated without the AM-3349/GRC-106, the output from internal alc assembly 1A1A2A5 is applied from pin 6 of connector J1 through diode A3CR6 to generate the necessary apc signal, as previously explained. When the receiver-transmitter is operated with the AM-3349/GRC-106 functioning, the output from the divider network on the chassis is of sufficient level that it will reverse-bias diode A3CR6 and override the internal alc signal.

g. Peak Power Control. The ppc circuit in this module (A3 fig. 4-39) is used to process the modulated dc output from the AM-3349/GRC-106 before application to the IF amplification circuit.

(1) The divider network on the chassis converts the automatic level control (alc) circuit output into the ppc and apc signals which differ from each other only in level. The ppc signal is applied to pin 8 of connector J1, from which it is applied through resistor A3R13 to the base of ppc dc amplifier A3Q4. Any rf signals present in the input are bypassed by capacitor A3C4. Ppc dc amplifier A3Q4 provides isolation between the

divider network on the chassis and the peak detection circuit (capacitor C5 and resistor R8).

(2) The output from ppc dc amplifier A3Q4 is used to charge capacitor A3C5, providing the base drive signal for ppc dc amplifier A3Q5. The charge time constant for capacitor A3C5 is very small, allowing it to charge to the peak level of the applied signal. The discharge path is through resistor A3R8. The discharge time constant is long compared to the frequency of the applied signal, but is short enough to follow the syllabic rate to maximize the average talk power and still hold the pep within the design limits. This action tends to compress the rf voice signal and thereby change the peak-to-average ratio to improve system performance.

(3) The voltage of charged capacitor A3C5 is the dc base drive signal for ppc dc amplifier A3Q5. Ppc dc amplifier A3Q5 provides isolation between the peak detection circuit and the input circuit for ppc attenuator A1Q1. The output from ppc dc amplifier A3Q5 is applied to the base of ppc attenuator A1Q1, determining the amount of attenuation of the IF signal applied to transmit IF amplifier A1Q3 (*e* above). This closes the ppc loop between the AM-3349/GRC-106 output and the receiver-transmitter input to prevent the peak power of the transmitted signal from exceeding a predetermined level.

(4) During transmit operation, the ppc signal is applied through resistor A3R10 to pin 4 of connector J1 for application to the signal level meter. The signal level meter then provides an indication of the amount of ppc signal required to control the rf power output level. In the receive mode of operation, the output from the step agc circuit in receiver IF module 1A7 is applied to the signal level meter (para 1-12). Diode A3CR3 provides the path to ground for this negative signal. Resistor A3R10 isolates the agc voltage from the emitter of ppc dc amplifier A3Q5. The similar path to ground for the ppc signal is located in receiver IF module 1A7 (para 1-12).

(5) When the receiver-transmitter is used alone or if the AM-3349/GRC-106 is not functioning, the output from internal alc assembly 1A1A5 is applied through pin 6 of connector J1 and diode A3CR4 to the base of ppc dc amplifier A3Q4. This signal is then used to generate the ppc signal as previously explained. When the receiver-transmitter is operated with the AM-3349/GRC-106 functioning, the output from the divider network on the chassis will reverse-bias diode A3CR4 and override the output from internal alc assembly 1A1A2A5.

1-7. Translator Module 1A8 (Transmit)

(fig. 4-42)

a. General. The function of translator module 1A8, during transmit operation, is to convert the 1.75 MHz IF to the desired rf. This is accomplished by mixing the 1.75 MHz IF with the outputs from 10 and 1 kHz synthesizer module 1A4 (para 1-17), 100 kHz synthesizer module 1A2, and MHz synthesizer module 1A9 (para 1-18), in a triple-conversion process. Only that part of Translator module 1A8, which is used during transmit operation, is explained in this paragraph. Refer to paragraph 1-11 for a description of the circuits used during receive operation.

NOTE

Prefix all reference designators in this paragraph with translator module reference designator 1A8, unless otherwise specified.

b. Main Signal Flow. The main signal flow is discussed below.

(1) The 1.75 MHz IF output from transmitter IF and audio module 1A5 (para 1-6) is applied to connector J1A-A2, from which it is coupled by capacitor A1C3 to the base of transmit low-frequency mixer A1Q1. During transmit operation, ground is applied to pin 3 of connector J1A. This terminates resistor A1R3, allowing the 20 volt dc supply voltage to be developed across base voltage divider A1R3 and A1R4. The output (one frequency between 4.551 and 4.650 MHz) from 10 and 1 kHz synthesizer module 1A4 (para 1-17) is applied to connector J1A-A1, from which it is coupled by capacitor A1C4 to the emitter of transmit low-frequency mixer A1Q1. Diode A1CR1 prevents the output from mixer A1Q1 from excessively reverse-biasing the base-to-emitter junction of receive low-frequency mixer A1Q2 which at this time, is turned off by applying the ground at pin 3 of connector J1 to both its emitter and base. In transmit low-frequency mixer A1Q1, the output from 10 and 1 kHz synthesizer module 1A4 is mixed with the 1.75 MHz IF. The resulting mixing products are applied to filter FL3. Filter FL3 is a multisection inductance-capacitance (LC) filter, which has a passband from 2.8 to 2.9 MHz. Therefore, all mixing products, except those within the passband, will be attenuated by filter FL3.

(2) Since pin 3 of connector J1A has ground on it and pin 5 of connector J1A has 20 volts dc on it, diode A2CR1 will be forward-biased and allow the output from filter FL3 to pass to the

base of transmit medium-frequency mixer A2Q2. The output from 100 kHz synthesizer module 1A2 (para 1-19) is applied to connector J1A-A4, from which it is coupled by capacitor A2C3 to the emitter of transmit medium-frequency mixer A2Q2. Diode A2CR1 is used to prevent receive medium-frequency mixer A2Q1 from being operational during the transmit mode. In transmit medium-frequency mixer A2Q2, the 2.80 to 2.90 output from filter FL3 is mixed with either the lo (a frequency between 22.4 and 23.3 MHz) or hi (a frequency between 32.4 and 33.3 MHz) output from 100 kHz synthesizer 1A2. If the lo band of frequencies is used, 20 volts dc will be present on pin 4 of connector J1A. This 20 volts dc is applied through resistor A2R10 and filter FL1 (fig. 4-42) to the anode of diode A2CR3 and through resistor A2R11 and filter FL2 to the cathode of diode A2CR5. The 20 volt dc supply line voltage is regulated to 10 volts dc by Zener diode A2VR1. This 10 volts dc is applied to the cathode of diode CR3 and the anode of diode A2CR5. Therefore, diode A2CR3 will be forward-biased and diode A3CR5 will be reverse-biased. The output from transmit medium-frequency mixer A2Q2 will then be allowed to pass to filter FL1. If the hi band of mixing frequencies is required, pin 4 of connector J1A will be at ground. This ground is then applied to diodes A2CR3 and A2CR5, forward-biasing diode A2CR5 and reverse-biasing diode A2CR3. Therefore, the output from mixer A2Q2 will be allowed to pass through diode A2CR5 to filter FL2.

(3) Filter FL1 and FL2 are both multisection inductor capacitor (LC) filters which attenuate all mixing products, except the difference product. The 10-volt dc output from Zener diode A2VR1 is applied to the anode of diode A3CR3 and the cathode of diode A3CR1. The hi/lo information (ground or +20 volts dc), present at pin 4 of connector J1A is applied through resistor A3R2 and filter FL1 to the anode of diode A3CR1 and through resistor A3R3 and filter FL2 to the cathode of diode A3CR3. Therefore, diode A3CR1 will be forward-biased when the lo band output from 100 KHz synthesizer 1A2 is used, and reverse-biased when the hi band is used. Diode A3CR3 will be forward-biased when the hi band is used and reverse-biased when the lo band is used. During transmit operation, 20 volts dc is applied to pin 5 of connector J1A. This 20 volts dc is applied through resistors A3R4 and A3R11 and transformer A3T1 to the anode of diode A3CR2. Since 10 volts dc is pre-

sent on the cathode, diode A3CR2 is forward-biased and allows the output from either filter FL1 or FL2 to pass. During receive operation, pin 5 of connector J1A is at ground. This ground is applied to the anode of diode A3CR2, reverse-biasing it and preventing any signal leakage through the transmit path. The output from either filter FL1 or FL2 is coupled by transformer A3T1 to a balanced mixer consisting of backward diodes A3CR8 and A3CR9. The output from MHz synthesizer module 1A9 (a frequency between 2.5 and 23.5 MHz) is applied to connector J1BA1 from which is coupled by capacitor A3C1 to the junction of resistors A3R9 and A3R10.

(4) The MHz injection frequencies will be developed across both halves of the primary of transformer A3T2. These two voltages will be nearly equal in amplitude but opposite in polarity. Therefore, the injection frequency (between 2.5 and 23.5 MHz) will be effectively canceled. The IF signal will take the low-impedance path through diodes A3CR9 rather than the path through the high inductance of transformer T2, therefore canceling itself. Resistors A3R9 and A3R10 are used to balance the circuit by compensating for changes in transformer impedance as the frequency varies. The output from the balanced mixer will be the sum and difference products of the two individual signals which is not canceled by the balanced circuit. This output is coupled by capacitor A3C7 to the base of transmit output amplifier A3Q2. Transmit output amplifier A3Q2 amplifies the rf signal and direct-couples it to transmit output amplifier A3Q3. Transmit output A3Q3 further amplifies the rf signal and develops it across transformer A3T3. Inductor A3L2 provides impedance matching between transmit output amplifier A3Q2 and transmit output amplifier A3Q3. Negative feedback is provided from the emitter to transmit output amplifier A3Q3 to the base of transmit output amplifier A3Q2 through capacitor A3C12 and resistor A3R23. This negative feedback compensates for low-frequency rolloff. Capacitors A3C8 and A3C14 provide emitter peaking to compensate for high-frequency rolloff. The degeneration in the circuits, created by resistors A3R20 and A3R24 as a result of not being completely bypassed, compensates for variations in transistor gain. The output from transmit output amplifier A3Q3 is coupled by capacitor A3C13 to connector J1BA4 for application to rf amplifier module 1A12 (para 1-8).

1-8. Rf Amplifier Module 1A12 (Transmit)

(fig. 4-46)

a. General. The function of rf amplifier module 1A12 during transmit operation is to amplify the output from translator module 1A8 (para 1-7) to a level suitable for driving Amplifier, Radio Frequency AM-3349/GRC-106. Highly selective input, interstage, and output tuned circuits are used to insure the complete rejection of all harmonic outputs from translator module 1A8 except the desired frequency to be transmitted.

NOTE

Prefix all reference designators used in this paragraph with Rf amplifier module reference designator 1A12, unless otherwise specified.

b. Rf Amplification.

(1) The output from translator module 1A8 is applied to connector J1A3, from which it is applied to the primary of transformer T1 on a megahertz assembly (chart C, fig. 4-46). The megahertz assembly connected into the circuit is dependent upon the setting of the frequency controls on the receiver-transmitter front panel. These assemblies are mounted on a motor-driven turret assembly, which is automatically tuned to insert the correct megahertz strip according to the operating frequency. The input portion of the megahertz assembly is made up of two parallel-tuned circuits with capacitive coupling. The first circuit consists of the secondary of transformer T1 and the capacitive network consisting of megahertz strip capacitor C2, capacitors C36, C32 and C40, and the capacitors on assemblies A30 and A31. The capacitors of assembly A30 are mechanically switched into the circuit by the 100 kHz control on the front panel (chart B, fig. 4-46). The capacitor to be used on assembly A31 is mechanically switched into the circuit by the 10 kHz control on the front panel (chart A, fig. 4-46).

(2) The output from the first tuned input circuit is coupled by capacitor C1 to the second tuned input circuit on the megahertz strip. The second tuned circuit consists of transformer T2 and the capacitive network consisting of megahertz strip capacitor C3, capacitors C33, C37, and C41, and the capacitors on assemblies A32 and A33. The purpose of these capacitors is the same as for the first tuned circuit ((1) above). Crystal Y1 is part of megahertz strips A5, A6, and A15 (chart C, fig. 4-46). This crystal functions as a trap to remove the spurious signals indicated in the chart.

(3) The rf output from the double-tuned input circuit is coupled by capacitor C7 to the control grid of rf amplifier V1. The 125-volt dc screen and plate voltage is applied to pin 5 of connector J1 from which it is applied through resistor R21 directly to the screen and through transformer T3 of the megahertz strip to the plate. The bias for amplifier V1 is developed by cathode resistor R16, which is rf bypassed by capacitor C6. Rf amplifier V1 amplifies the rf signal and develops it across a tuned circuit. The tuned circuit consists of megahertz strip transformer T3 and a capacitive network consisting of megahertz strip capacitor C4, capacitors C34, C38, and C42, and the capacitors on assemblies A34 and A35. The functions of the individual parts are the same as for the comparable parts in (1) above.

(4) The output from rf amplifier V1 is applied to the control grid of rf amplifier V2. Rf amplifier V2 is identical with rf amplifier V1. It amplifies with rf signal to the level suitable for driving the AM-3349/GRC-106. The output from rf amplifier V2 is developed across a tuned circuit consisting of the primary of megahertz strip transformer T4 and a capacitive network consisting of megahertz strip capacitor C5, capacitors C35, C39, and C43, and the capacitors on assemblies A36 and A37. The functions of the individual parts are comparable to the parts in (1) above.

(5) The output from rf amplifier V2 is coupled by transformer T4 to connector J1A1. This rf signal is applied through relay 1A1K4 (fig. 4-33) to the RF DRIVE connector on the RT-662/GRC or RT-834/GRC front panel for application to the AM-3349/GRC-106.

Section IV. RECEIVER SECTION CIRCUIT ANALYSIS, RECEIVER-TRANSMITTER, RADIO RT-662/GRC AND RT-834/GRC

1-9. General

The receiver section of the radio set is used to convert rf signals received on any one of the RT-662/GRC 28,000 operable frequencies or RT-834/GRC 280,000 operable frequencies in the 2.0 to 29.999 megahertz frequency range to audio intelligence for either an ssb, fsk, cw, nsk, or compatible am mode of operation. The audio output from the receiver-transmitter is at a 2-watt or a 10-milliwatt level, suitable for driving Handset H-33(*)/PT or Dynamic Loudspeaker LS-166/U.

1-10. Rf Amplifier Module 1A12 (Receive)

(fig. 4-46)

a. General. The function of rf amplifier module 1A12 during receive operation is to raise the level of the received rf signal to one suitable for use in translator module 1A8 (para 1-11). The highly selective tuned input, interstage, and output circuits are used to reduce adjacent channel interference, increase image rejection, and prevent cross-modulation.

NOTE

Prefix all reference designators used in this paragraph with Rf amplifier module reference designator 1A12, unless otherwise specified.

b. Rf Amplification.

(1) The rf signals present at the RECEIVER IN connector on the receiver-transmitter are

applied to connector J1A3 (fig. 4-46) through relay 1A1K3 (fig. 4-33). The parts used (fig. 4-46) and the functions of the tuned input circuit, rf amplifier V1, tuned interstage circuit, rf amplifier V2, and the tuned output circuit are the same as during transmit operation (para 1-8).

(2) The gain of rf amplifiers V1 and V2 is controlled by the step agc circuit or the setting of the MANUAL RF GAIN control on the receiver-transmitter front panel (para 1-12). The agc output from Receiver IF module 1A7 is applied to pin 3 of connector J1. This negative level is developed across voltage dividers R24, R26, and R23, R101 to shift the bias of rf amplifiers V2 and V1, in order to maintain a nearly constant output from rf amplifier module 1A12 regardless of applied signal strength.

1-11. Translator Module 1A8 (Receive)

(fig. 4-42)

a. General. Translator module 1A8 during receive operation converts the rf input signal to the 1.75 MHz IF. This is accomplished by mixing the rf signal with the outputs from MHz synthesizer module 1A9 (para 1-18), 100 kHz synthesizer module 1A2 (para 1-19), and 10 and 1 kHz synthesizer module 1A4 (para 1-17) in a triple heterodyning process. Only that portion of translator module 1A8 that is used during receive operation is explained in this paragraph. Refer to paragraph 1-7 for a description of the circuits used during transmit operation.

NOTE

Prefix all reference designations in this paragraph with translator module reference designator 1A8, unless otherwise specified.

b. Main Signal Flow.

(1) The output from rf amplifier 1A12 is applied to connector J1B-A2, where it is coupled to the base of receive high-frequency mixer A3Q1. The amplitude of large signals applied to the base of receive high-frequency mixer A3Q1 is limited by diodes A3CR4 and A3CR5. The output from MHz Synthesizer module 1A9 (a frequency between 2.5 and 23.5 MHz) is applied to connector J1B-A1, from which it is coupled by capacitor A3C16 to the emitter of receive high-frequency mixer A3Q1. Receive high-frequency mixer A3Q1 is turned on during receive operation by terminating resistor A3R7 with the ground present at pin 5 of connector J1A. This allows the 20 volts dc supply voltage to be developed across base-bias voltage divider A3R13, A3R7. During transmit operation, receive high-frequency mixer A3Q1 is turned off by the application of the 20 volts dc present at pin 5 of connector J1A to resistor A3R7 in place of ground. This applies 20 volts dc to both ends of the voltage divider, preventing receive high-frequency mixer A3Q1 from conducting. Diode A3CR6 protects the emitter-to-base junction of receive high-frequency mixer A3Q1 from being excessively reverse-biased. During transmit operation, diode A3CR7 is reverse-biased by the 10 volts dc output from Zener diode A2VR1 on the anode and the 20 volts dc at pin 5 of connector J1A on the cathode. This prevents any MHz injection from leaking through receive high-frequency mixer A3Q1 into the transmit path. During receive operation, the 20 volts dc at pin 5 of connector J1A is replaced by ground. Therefore, the output from receive high-frequency mixer A3Q1 will be allowed to pass.

(2) The output from receive high-frequency mixer A3Q1 is applied to either filter FL1 or filter FL2. The filter to which the signal is applied depends on whether diode A3CR1 or diode A3CR3 has been forward-biased by the hi/lo information present on terminal A3E11 from pin 4 of connector J1A (para 1-6). Filters FL1 and FL2 attenuate all mixer products, except those in the passband of the filter. The output from filter FL1 or filter FL2 is applied to the base of receive medium-frequency mixer A2Q1. Either diode A2CR3 or diode A2CR5 will be forward-biased

by the hi/lo information present at pin 4 of connector J1A. Diode A2CR2 will be forward-biased during receive operation due to the 10 volts dc from Zener diode A2VR1 on the anode and the ground at pin 5 of connector J1A on the cathode.

(3) The output from 100 kHz synthesizer module 1A2 is applied to connector J1A-A4, from which it is coupled to the emitter of receive medium-frequency mixer A2Q1. When diode A2CR2 is forward-biased, the 10 volts dc at Zener diode A2CR1 is developed across resistor A2R9, which is terminated by the ground present at pin 5 of connector J1A. Since 20 volts dc is present on the emitter, receive medium-frequency mixer A2Q1 is forward biased. During transmit operation, pin 5 of connector J1A is at 20 volts dc. Therefore, both the base and emitter of receive medium-frequency mixer A2Q1 are at 20 volts dc, there is no conduction. The output from either filter FL1 or filter FL2 is mixed with its respective lo (frequency between 22.4 and 23.3 MHz) or hi (frequency between 32.4 and 33.3 MHz) band input frequency by receive medium-frequency mixer A2Q1. The output from receive medium-frequency mixer A2Q1 is applied to filter FL3.

(4) Filter FL3 passes only the difference product, which must lie in the 2.80 to 2.90 MHz passband. Since pin 3 of connector J1A is at 20 volts dc during receive operation, diode A1CR1 will be forward-biased. Therefore, the 2.80 to 2.90 MHz output from filter FL3 is applied to the base of receive low-frequency mixer A1Q2. Resistor A1R10 provides a shunt effect on the input load to prevent any instability in receive low-frequency mixer A1Q2. Since pin 3 of connector J1A is at 20 volts dc during receive operation, base bias will be developed for receive low-frequency mixer A1Q2 by voltage divider A1R6 and A1R9. During transmit operation, both the emitter and base of receive low-frequency mixer A1Q2 are connected to the ground present at pin 3 of connector J1A; therefore, it remains cut off. The output from 10 and 1 kHz synthesizer module 1A4 (a frequency between 4.551 and 4.650 MHz) is applied to connector J1A-A1 from which it is coupled to the emitter of receive low-frequency mixer A1Q2 by capacitor A1C5. Receive low-frequency mixer A1Q2 mixes the 2.80 to 2.90 MHz output from filter FL3 with the injection frequency (frequency between 4.551 and 4.650 MHz) and develops the resulting products across the tuned circuit consisting of capacitor A1C6 and the primary of transformer A1T1. This tuned circuit is tuned to the difference

product, 1.75 MHz, effectively eliminating all other receive signals. The output of low-frequency mixer A1Q2 is coupled by transformer A1T1 to connector J1A-A3, from which it is applied to receiver IF module 1A7 (para 1-12).

1-12. Receiver IF Module 1A7

(fig. 4-41)

a. General. Receiver IF module 1A7 during receive operation provides IF selectivity, IF amplification, detection of the IF signal, IF agc, agc for rf amplifier module 1A12, and the bfo injection frequency. This module also provides the modulation capability for transmit operation.

NOTE

Prefix all reference designators in this paragraph with the receiver IF module reference designator 1A7, unless otherwise specified.

b. IF Amplification.

(1) The 1.75 MHz IF output from translator module 1A8 is applied to connector J1A2 from which it is coupled by capacitor A4C11 to the cathode of diode A4CR4. During receive operation, ground is applied to pin 9 of connector J1 and 20 volts dc is applied to pin 2 of connector J1. The ground is applied to the cathode and the 20 volts dc is applied to the anode of diode A4CR4, forward-biasing it and allowing the 1.75 MHz IF input to pass. From the anode of diode A4CR4, the 1.75 MHz IF is coupled by capacitor A4C12 through matching resistor A4R8 to ssb crystal filter FL1. Ssb crystal filter FL1 establishes a 3.2 kHz IF bandwidth to provide the required selectivity.

(2) The output from ssb crystal filter FL1 is coupled by capacitor A1C1 to a voltage divider consisting of resistor A1R1 and agc attenuator A1Q1. Agc attenuator A1Q1 acts as a variable shunt resistance to ground, the resistance of which is varied by the dc voltage from the step agc circuit (*c* below). The dc output from the step agc circuit (above the agc threshold) is controlled by the received signal strength. This dc voltage is developed across the temperature-compensated voltage divider consisting of resistors A1R3 and A1R2, thermistor A1R22, and diode A1CR2. The resistance of thermistor A1R22 and diode A1CR2 both vary inversely with temperature. Capacitor A1C2 provides unity feedback, placing an ac short between collector and the

base. Therefore, both the collector-to-emitter resistance form a part of the total shunt resistance for controlling the level for the IF signal input to 1.75 MHz IF amplifier A1Q2. Diode A1CR1 provides temperature compensation for agc attenuator A1Q1. The output from the voltage divider is coupled by capacitor A1C3 to the base of 1.75 MHz IF amplifier A1Q2.

(3) The gain of 1.75 MHz IF amplifier A1Q2 is controlled by agc degenerator A1Q3. Agc degenerator A1Q3 acts as a variable resistive-degenerative element in series with emitter bypass capacitor A1C5. The base voltage for agc degenerator A1Q3 is developed from the 20 volts dc supply line by voltage divider A1R4, A1R9, A1R10 and the collector-to-emitter and base-to-emitter resistances of agc attenuator A1Q1. With weak received signals, the output from the step agc circuit will be zero, causing agc attenuator A1Q1 to be cutoff. This provides maximum shunt resistance (least attenuation), biasing agc degenerator A1Q3 into saturation, and effectively grounding emitter bypass capacitor A1C5. Therefore, the output from 1.75 MHz IF amplifier A1Q2 will be maximum. As the signal strength increases, agc attenuator A1Q1 will conduct. The amount of conduction will be controlled by the received signal strength (above agc threshold). The shunt resistance will decrease as the rate of conduction increases, decreasing the amount of signal applied to the base of 1.75 MHz IF amplifier A1Q2. As the rate of conduction of agc attenuator A1Q1 increases, the dc voltage present at the collector will decrease. Therefore, the bias level on agc degenerator A1Q3 will decrease, decreasing its rate of conduction. This will increase the impedance in series with emitter bypass capacitor A1C5, providing increased degeneration to decrease the gain of 1.75 MHz IF amplifier A1Q2. Agc attenuator A1Q1 and agc degenerator A1Q3 together provide greater than 40 dB of control to maintain the output from 1.75 MHz IF amplifier A1Q2 at a nearly constant level for variations in the level of the input signal. The output from 1.75 MHz IF amplifier A1Q2 is developed across the tuned circuit consisting of transformer A1T1 and capacitor A1C6. From here, the IF signal is coupled by capacitor A1C7 to the base of 1.75 MHz IF amplifier A1Q4, and by capacitor A1C13 to the base of 1.75 MHz IF amplifier A1Q5.

(4) The 1.75 MHz IF amplifier, A1Q4 amplifies the 1.75 MHz signal and develops it across the tuned circuit consisting of capacitor A1C9 and the primary of transformer A1T2. Transformer

A1T2 couples the 1.75 MHz IF signal to the bases of transistors A2Q8 and A2Q9 in the product detector (*c* below). The 1.75 MHz IF amplifier, A1Q5, amplifies the 1.75 MHz signal and develops it across the tuned circuit consisting of capacitor A1C15 and transformer A1T3. Transformer A1T3 couples the 1.75 MHz signal to connector J1A3 for application to the IF OUT connector on the front panel of the receiver-transmitter. This allows 1.75 MHz signal to be used for external purposes.

c. Product Detector. The product detector is used to extract the audio from the receive IF signals. The input to the product detector is the 1.75 MHz IF output from 1.75 MHz IF amplifier A1Q4 (*b* above). The input signal is applied to the bases of transistors A2Q8 and A2Q9, which are connected in a balanced mixer configuration. Base bias for transistors A2Q8 and A2Q9 is developed by voltage divider A1R16 and A1R17 and is applied through the secondary of transformer A1T2. The collector voltage for transistors A2Q8 and A2Q9 is applied through the primary of transformer A2T3. In all modes of operation, except cw, diode A3CR5 is forward-biased by the voltage developed by voltage divider A3R10 and A3R13. This allows the 1.75 MHz present at connector J1A4 to be coupled by capacitor A3C13 through diode A3CR5 to attenuator A3R11 and A3R12. Resistor A3R11 sets the level of the 1.75 MHz signal that is coupled by capacitors A2C19 and A2C14 to the emitters of transistors A2Q8 and A2Q9. During cw operation, the output from the bfo circuit is applied to the emitters of transistors A2Q8 and A2Q9 instead of the 1.75 MHz injection present at connector J1A4. The 1.75 MHz IF and the 1.75 MHz injection or bfo signals are mixed by transistors A2Q8 and A2Q9, resulting in an output consisting of the sum of the two signals, and the difference between the two signals (the desired audio). Capacitors A2C15 and A2C16 bypass the sum of the two signals. Since the circuit is balanced, the outputs from transistors A2Q8 and A2Q9, which are developed across the primary of transformer A2T3, and 180° out of phase with each other. This results in the cancellation of the 1.75 MHz injection and the 1.75 MHz IF transformer A2T3 has an audio frequency response that will attenuate any of the rf signals not previously canceled. The difference between the two signals (the desired audio) is coupled by capacitor A2C17 to the base of amplifier A2Q10. Amplifier A2Q10 amplifies the audio signal and develops it across collector resistor A2R24. The out-

put from amplifier A2Q10 is coupled by capacitor A2C20 to pins 29 and 30 of connector J1 for application to receiver audio module 1A10 (para 1-13) and the AUDIO GAIN control on the receiver-transmitter front panel.

d. Step Age Circuit.

(1) The 1.75 MHz IF output from 1.75 MHz IF amplifier A1Q2 (*b* above) is coupled from A1T1 by capacitor A2C1 to the base of 1.75 MHz IF amplifier A2Q1. The 1.75 MHz IF amplifier A2Q1 amplifies the 1.75 MHz IF signal and develops it across the tuned circuit consisting of capacitor A2C3 and transformer A2T1. The tuned circuit signal is coupled by capacitor A2C5 to the base of 1.75 MHz IF amplifier A2Q2. The signal is amplified by A2Q2 and is developed across the tuned circuit consisting of capacitor A2C7 and transformer A2T2. Two outputs, identical in frequency and polarity but differing in amplitude by 20 percent, are taken from transformer A2T2. One output, designated E1, is applied to the anode of hang detector A2CR2. The other output, designated 1.2 E1, is applied to time detector A2CR1. The 1.2 E1 signal is rectified by diode A2CR1, and the resulting dc level is applied to the base of dc amplifier A2Q3. This increase of base voltage will cause increased conduction and thus increase the voltage across capacitor A2C10, providing a 1.2 E1 signal. The E1 signal is rectified by hang detector A2CR2 and is used to charge capacitor A2C9, providing an E1 signal. Capacitor A2C8 and resistor A2R9 provide IF filtering for hang detector A2CR2. Diode A2CR3 prevents capacitor A2C9 from discharging through resistor A2R9.

(2) The voltage on capacitor A2C10 provides the dc signal for hang age switch A2Q4. The charge on capacitor A2C9 provides the emitter bias for hang age switch A2Q4 and the dc signal for dc amplifier A2Q5. As long as the signal is present at the antenna, hang age switch A2Q4 will be reverse-biased and the E1 signal on the emitter will prevent conduction. When the antenna signal (and therefore the IF signal) is removed, capacitor A2C10 will discharge through resistor A2R10 and capacitor A2C9 will discharge (more slowly than A2C10) through the high input impedance of dc amplifier A2Q5. After a predetermined discharge time, E1 will be sufficiently greater than 1.2 E1 to forward bias hang age switch A2Q4, causing it to conduct. Capacitor A2C9 will then rapidly discharge to ground through hang age switch A2Q4, removing the dc signal from dc amplifier A2Q5. If, during this process, new signal information is received, the

step agc circuit will immediately reset on the new information as described above.

(3) Since $1.2 E_1$ and E_1 are proportional to the IF signal, the strength of the received signal determines the level to which capacitor A2C9 charges, and thereby, determines the dc signal at the base of dc amplifier A2Q5. The hangtime (time needed to turn on hang agc switch A2Q4 after the input signal is removed) of the previous circuits as described in (2) above is of sufficient duration to maintain a relatively constant charge on capacitor A2C9 for normal pauses in voice signals. Whenever a charge is present on capacitor A2C9, dc amplifier A2Q5 will be forward-biased, which in turn forward-biases dc amplifier A2Q6. The output from dc amplifier A2Q6 is filtered by capacitor A2C11 to remove any remaining 1.75 MHz IF across resistor A2R12. Resistor A2R12 is used to adjust the dc level which is applied to agc attenuator A1Q1 and agc degenerator A1Q3 (*b* above), providing the required IF agc. The output from dc amplifier A2Q6 (present at wiper of resistor A2R12) is also applied across voltage divider A2CR4, A2CR5, A2R14 for supplying the rf agc.

(4) Since the rf circuits of a receiver determine its sensitivity to weak signals, and the application of agc to these circuits tends to decrease this weak signal capability, it is desirable to apply agc to the rf amplifier circuits only when received signal strength is above a sufficient preset level. For this reason, diodes A2CR4 and A2CR5 are used in a network to make the agc threshold for the rf circuits higher than that for the IF circuits. Resistors A2R14 and A2R12 are used to set the base bias for dc amplifier A2Q7. For normal operation, the MANUAL RF GAIN control is set for maximum sensitivity. This results in only a small dc voltage applied through pin 8 of connector J1 to the anode of diode A2CR6. With the MANUAL RF GAIN control set as above, the output from dc amplifier A2Q6 will back-bias diode A2CR6. Therefore, the output from dc amplifier A2Q6 will be the dc signal for dc amplifier A2Q7. To desensitize the receiver manually for reception of strong signals, the MANUAL RF GAIN control is set to override the normal rf agc. This is done by rotating the MANUAL RF GAIN control counterclockwise, which increases the positive dc level at pin 8 of connector J1. When the dc level is of sufficient magnitude to forward-bias diode A2CR6, it will override the dc signal applied by dc amplifier A2Q6 at the base of dc amplifier A2Q7. With no signal input at the antenna, the base of dc amplifier A2Q7

will be effectively at ground, unless the MANUAL RF GAIN control is set to some position other than for maximum sensitivity. This causes dc amplifier A2Q7 to conduct into saturation, resulting in a zero or slightly positive voltage at the collector. Diode A2CR7 prevents the application of any detrimental positive levels to rf amplifier module 1A12 (para 1-5). As the signal strength at the antenna increases, the dc signal at the base of dc amplifier A2Q7 will increase. This decreases the forward bias of dc amplifier A2Q7, causing the collector voltage to go more negative, approaching -24 to -30 volts dc. When the SERVICE SELECTOR switch is set at STAND BY, the 20 volts dc applied to dc amplifier A2Q7 is removed and its collector voltage goes to -33 volts dc, biasing the tubes in rf amplifier module 1A12 off. A portion of the rf agc signal is applied through pin 7 of connector J1 to the signal level meter to provide an indication of the relative strength of the rf input signal. Diode A2CR8 closes the conduction path for the signal level meter when transmitting.

e. Bfo Circuit. The bfo circuit provides an output of 1.752 ± 0.0035 MHz for injection into the product detector (*c* above). This allows the operator to vary the audio tone 3.5 kHz during cw operation. Bfo A3Q1 is a crystal-controlled Clapp oscillator that produces a 7.000 MHz output. The output from bfo A3Q1 is applied to the base of bfo converter A3Q2. The other input to bfo converter A3Q2 is the output from the series-resonant circuit consisting of voltage variable capacitor (vvc) A3CR1, inductor A3L3, and crystal A3Y2. The output frequency of the series-resonant circuit signal depends upon the dc control voltage applied to the vvc by the BFO control on the front panel. The vvc is biased by the voltage developed by voltage divider A3R6, A3CR2, A3CR3 to provide a 1.752 MHz output from the bfo circuit when the BFO control is set at its center position. One end of the BFO control is connected to pin 12 of connector J1 to provide a variable voltage for vvc A3CR1 and the other end is connected to +20 volts dc. A vvc is a nonlinear device; therefore, swamping resistor A3R5 is connected across the BFO control to make it correspondingly nonlinear. The value of resistor A3R5 is such that the nonlinear action of vvc A3CR1 is canceled, resulting in essentially linear frequency control with the BFO control. With the BFO control set at its maximum position, inductor A3L3 is set so that the output of the series-resonant circuit is approximately 8.7555 MHz. With the BFO control set at its minimum posi-

tion, resistor A3R4 is set so that the output of the series-resonant circuit is approximately 8.7485 MHz. This allows the operator to vary the output 3.5 kHz in cw operation. The 7.000 MHz is subtractively mixed with the output from self-oscillating bfo converter A3Q2, producing a 1.752 MHz \pm 3.5 kHz output across the tuned circuit for bfo buffer amplifier A3Q3. The output from bfo buffer amplifier A3Q3 is gated through diode A3CR4 to the product detector circuit (c above), in place of the 1.75 MHz local carrier used in the other modes of operation.

f. Balanced Modulator. The balanced modulator is used to obtain the double-sideband, suppressed-carrier IF signal. This circuit is the first step in converting the audio to the transmitted rf.

(1) During transmit operation, the 1.75 MHz output from frequency dividers module 1A6 (para 1-16) is applied to connector J1A4, from which it is coupled to the collector of 1,750 kHz switch A4Q2. In transmit, pin 9 of connector J1 has +20 volts dc applied to it. This +20 volts dc is used to bias 1,750 kHz switch A4Q2 on. When the switch turns on, it presents a small series resistance (collector-to-emitter) to the 1.75 MHz input. This resistance, in combination with resistor A4R11, forms a voltage divider to set the level of 1.75 MHz coupled to the center-tapped primary to transformer A4T2.

(2) The 1.75 MHz output from 1,750 kHz switch A4Q2 is applied to the center tap on the primary of transformer A4T2. The audio input from transmitter IF and Audio module 1A5 is applied to pin 3 connector J1 from which it is applied to the center tap of the primary of transformer A4T2. The audio and 1.75 MHz inputs are mixed by backward diodes A4CR1A and A4CR1B. Resistor A4R16 and potentiometer A4R4 are used to resistively balance both arms of the balanced modulator circuit. Capacitor A4C7 is used to balance any reactive components in the circuit. Therefore, the circuit is set so that both arms are balanced. Resistor A4R15 provides a constant low-resistance load for the balanced modulator. The 1.75 MHz signal will be of equal potential across both halves of the primary of transformer A4T2, thereby canceling the 1.75 MHz signal. Due to the rf response of transformer A4T2, the audio components will be attenuated. Therefore, the output from the balanced modulator will be the sum (upper sideband) and difference (lower sideband) products of the audio and 1.75 MHz signal. The output from the balanced modulator is coupled by capacitor A4C5

to the base of buffer amplifier A4Q1. Buffer amplifier A4Q1 amplifies the double-sideband IF signal and develops it across the tuned circuit consisting of capacitor A4C4 and transformer A4T1.

(3) When the set is placed in tune condition, a ground is applied to pin 13 of connector J1 from AM-3349/GRC-106 in order to effectively turn off the balanced modulator in this condition. This ground is applied to the base of 1,750 kHz switch A4Q2, shutting it off, and thus blocking the 1.75 MHz injection at the collector. During receive operation, ground is applied to pin 9 of connector J1, shutting 1,750 kHz switch A4Q2 off to turn off the balanced modulator. When the 20 volts dc is initially applied (transmit mode), capacitor A4C18 will charge through resistors A4R11 and A4R13. The voltage applied to the base of 1,750 kHz switch A4Q2. Therefore, since the base voltage is increased exponentially, 1,750 kHz switch A4Q2 will be turned on exponentially. This delays the IF output from the receiver-transmitter, preventing the AM-3349/GRC-106 from being overdriven before the automatic level control signals have time to apply their control.

(4) During transmit operation, ground is applied to pin 2 of connector J1 and 20 volts dc is applied to pin 9 of connector J1. The ground is applied to the anode of diode A4CR4 and the cathode of diode A4CR3. The +20 volts dc is applied to the cathode of diode A4CR4, and the anode of diode A4CR3. Therefore, diode A4CR3 will be forward-biased. The output from buffer amplifier A4Q1 is coupled by capacitor A4C9 to diode A4CR3 is forward-biased, the signal will pass and be coupled to filter FL1 by capacitor A4C12. Filter FL1 removes the lower sideband component of the signal and further attenuates any of the 1.75 MHz carrier that was not canceled by the balanced modulator circuit. The upper sideband 1.75 MHz IF is applied to connector J1A1 for application to transmit IF and audio module 1A5 (para 1-6).

1-13. Receiver Audio Module 1A10

(fig. 4-44)

a. General. Receiver audio module 1A10 amplifies the audio output from receiver IF module 1A7 to levels of 10 milliwatts and 2 watts. Since the audio input can contain noise as well as voice, a squelch circuit is employed in this module to squelch background noise in the absence of a received voice signal. The 10-milliwatt output is

used for driving Headset H-227/U or Handset H-33/PT. The 2-watt output is used to drive Dynamic Loudspeaker LS-166/U.

NOTE

Prefix all reference designators in this paragraph with receiver audio module reference designator 1A10, unless otherwise specified.

b. Audio Amplification.

(1) The audio output from receiver IF module 1A7 is applied to pin 12 of connector J1 through the AUDIO GAIN control (fig. 4-33) on the receiver-transmitter front panel. The AUDIO GAIN control is used to vary the level of the audio signal coupled by the capacitor A2C1 (fig. 4-44) to the base of squelch gate A2Q3. If the SQUELCH switch is set at OFF, a ground will be present at pin 13 of connector J1. This ground will be applied to emitter resistor A2R5 to complete the emitter circuit and allow an output from squelch gate A2Q3 to be developed. If the receiver-transmitter is being operated in the cw or fsk mode of operation, a ground is applied to pin 5 of connector J1. This ground will be applied through diode A2CR2 to terminate emitter resistor A2R5. If the SQUELCH switch is set at ON, the squelch circuit (*c* below) will compare the voice level to the noise level. If the voice is predominant, squelch switch A2Q1 will be biased on, effectively terminating emitter resistor A2R5 to ground through a small collector-to-emitter resistance of squelch switch A2Q1 (*c* below). If the incoming signal is predominantly noise, squelch switch A2Q1 does not conduct. Therefore, resistor A2R5 will be open and the input will not be allowed to pass (will be squelched). In order that the operator can be aware of the presence of signals when the unit is squelched, a bypass path is provided through resistors A2R2 and A2R1, making the operator aware that the set is operating. If it is necessary to receive signals that are below the squelch threshold, the SQUELCH switch can be set at OFF to allow the full audio output to be available. Resistor A2R2 is normally set to provide a squelched-to-non-squelched ratio of 20 dB at the audio outputs.

(2) When emitter resistor A2R5 is grounded, the audio signals present at the base of squelch gate A2Q3 will be developed across emitter resistor A2R5. The audio is then coupled by capacitor A2C2 to the base of 10 mw output amplifier Q1 and to the base of audio driver Q2. Capacitors A2C6 and A2C7 are used to block dc from the input and equalize the low-frequency

response of the two channels. Resistors A2R11 and A2R12 are used to compensate for the amplifier input requirement so that each of the two channels can simultaneously produce its required output from a common source.

(3) The audio signal is raised to a level of 10 milliwatts by 10 mw output amplifier Q1. Inductor L1 is used to provide frequency dependent degeneration, in order to provide rolloff to attenuate frequencies above the 3,500 Hz voice range. Collector-to-base feedback (through resistor R3) is used to improve the stability and minimize the distortion of 10 mw output amplifier Q1. The output from 10 mw output amplifier Q1 is developed across a portion of the primary of transformer T1. Transformer T1 couples the audio signals to pin 14 of connector J1 for application to the AUDIO connectors on the receiver-transmitter front panel. The 10 millivolt output is used to drive the H-227/U or H-33/PT. Capacitors C5 and C8 are used to bypass signals above 3,500 cps. Transformer T1 transforms the output impedance of amplifier Q1 to the desired 600 ohms for matching the impedance of the H-33(*)/PT or H-227/U.

(4) Audio driver Q2 amplifies the audio signals sufficiently to drive 2 watt, push-pull output amplifier Q3A and B. Degeneration (developed by resistor R8) and collector-to-base feedback (through resistor R5) are used to improve the stability and minimize the distortion of audio driver Q2. The output from audio driver Q2 is developed across the primary of transformer T2. Transformer T2 couples the signal to the bases of 2 watt, push-pull output amplifiers Q3A and B. Base bias for 2 watt, push-pull output amplifiers Q3A and B is developed from the 20 volts dc supply by the temperature-compensated voltage divider consisting of resistors R10 and R12 and sensistor R11. Collector-to-base feedback (through capacitors C6 and C7) is used to provide rolloff for frequencies above 3,500 Hz. The 2 watt, push-pull output amplifier Q3A and B, amplifies the audio signal to a 2 watt level. This output is applied to pin 15 of connector J1 for application to the audio connectors on the RT-662/GRC or RT-834/GRC front panel. This output is used for driving the LS-166/U.

c. Squelch.

(1) The audio output from receiver IF module 1A7, which is applied to the AUDIO GAIN control is also applied to pin 6 of connector J1. From pin 6 of connector J1, the audio is coupled by capacitor A1C1 to a voltage divider consisting of resistor A1R1 and the collector-to-emitter re-

sistance of age attenuator A1Q1, which is controlled by an age loop. The collector-to-emitter resistance is inversely proportional to the level of the signal input, as determined by the output from age dc amplifier A1Q3. The voltage divider provides a nearly constant output, which is coupled by capacitor A1C2 to the base of age af amplifier A1Q2. Resistor A1R2 is used to isolate the voltage divider from the input impedance of age af amplifier A1Q2 in order to insure maximum control range. The audio output from the voltage divider is amplified by A1Q2 and is coupled by capacitor A1C4 to the base of age of amplifier A1Q4. Degeneration developed by resistor A1R6 and collector-to-base feedback through resistor A1R5 are used to improve the stability and minimize the distortion of age af amplifier A1Q2. Age af amplifier A2Q4 further amplifies the audio signal and develops it across the primary of transformer A1T1. Collector-to-base feedback (through resistor A1R12) is used to improve the stability and minimize the distortion of age af amplifier A1Q4. Transformer A1T1 couples the audio output from age af amplifier A1Q4 to high-pass filter A2C4, A2L2, low-pass filter A2L1, A1C10, and also to an age feedback circuit consisting of age rectifier A1CR1, age attenuator A1Q1, and age dc amplifier A1Q3. This circuit forms a closed age loop with age audio amplifier A1Q2 and A1Q4. Zener diodes A1VR2 and A1VR3 provide clipping for any peaks that exceed their firing points.

(2) The audio output from age af amplifier A1Q4 is detected by age rectifier A1CR1 and developed across A1R9. This voltage is filtered by capacitor A1C6 and used as the dc drive signal for age dc amplifier A1Q3. This dc level is raised by age dc amplifier A1Q3, filtered by capacitor A1C3, and used to bias age attenuator A1Q1. As the input signal increases, the dc output from age dc amplifier A1Q3 will increase, decreasing the collector-to-emitter resistance of age attenuator A1Q1. This will decrease the input to age af amplifier A1Q2. Similarly, as the signal decreases, the collector-to-emitter resistance of age attenuator A1Q1 increases, increasing the signal level at the base of age af amplifier A1Q2. Since this is a closed loop, the input to age af amplifier A1Q2 is maintained at a nearly constant level after the initial stabilization.

(3) Low-pass filter A2L1, A1C10 allows the portion of the input frequencies between approximately 400 and 600 Hz to pass to the base of voice-sensing detector A1Q5. The positive portions of the applied signals will bias voice-sensing

detector A1Q5 on and the negative portions will keep voice-sensing detector A1Q5 cutoff. Therefore, voice-sensing detector A1Q5 will act as a half-wave rectifier. This positive dc output is filtered by capacitor A1C8 and applied to one end of resistor A2R10 (SQUELCH SENS control).

(4) High-pass filter A2C4, A2L2 allows only the portion of the input frequencies above approximately 1,200 Hz to pass to the cathode of noise-sensing detector A2CR3. Noise-sensing detector A2CR3 rectifies the negative portions of the signals. This negative dc potential is filtered by capacitor A2C5 and is applied to the other end of resistor A2R10 (SQUELCH SENS control).

(5) Since voice energy is concentrated primarily in the 400 to 600 Hz range and the received noise energy is equally distributed throughout the audio range, the two filter circuits ((3) and (4) above) allow discrimination of voice input from no voice input conditions. In the case of no voice input, approximately equal signals will pass through the two filters, with the result that the dc voltage at the wiper of resistor A2R10 will be insufficient to cause squelch switch A2Q2 to conduct. When voice is present, most of its energy will pass through the low-pass filter ((3) above), causing an increased positive dc voltage on the wiper of resistor A2R10. If the voice level is sufficiently above the ambient noise, the resulting dc voltage at the wiper of resistor A2R10 will be sufficient to cause conduction in squelch switch A2Q2. Resistor A2R10 is set so that the ratio between the voice and noise must be of a predetermined value, before squelch switch A2Q2 will conduct.

$$s+n$$

(6) If the $\frac{\quad}{n}$ ratio is of a predetermined

$$n$$

value (voice is predominant), the voltage of the wiper or resistor A2R10 will forward bias squelch switch A2Q2 into conduction and its output will be filtered by capacitor A2C3. If the SQUELCH switch is set at ON, squelch switch A2Q1 will be biased on and conduct. When squelch switch A2Q1 conducts, emitter resistor A2R5 will be grounded through the small collector-to-emitter resistance of squelch switch A2Q1, allowing the audio to pass to the amplification circuits (b above). If the noise predominates, the voltage at the wiper of resistor A2R10 will not be sufficiently positive to bias squelch switch A2Q2 on. Therefore, resistor A2R5 will not be grounded. This keeps squelch gate A2Q3 nonconducting, forcing the noise signals to be dissipated in resistive divider A2R1 and A2R2 and be squelched.

Section V. FREQUENCY SYNTHESIS CIRCUIT ANALYSIS, RECEIVER-TRANSMITTER, RADIO RT-662/GRC AND RT-834/GRC

1-14. General

a. The frequency synthesis section of the receiver-transmitter will be presented in two parts. A discussion of the RT-662/GRC is given in paragraphs 1-15 through 1-21. Also contained in these paragraphs is the module functioning. Frequency synthesis for the RT-834/GRC is given in paragraphs 1-22 through 1-24. Modules which are common to both the RT-662/GRC and the RT-834/GRC will not be discussed in these paragraphs.

b. The frequency synthesis section of the Receiver-Transmitter RT-662/GRC consists of five modules, the function of which is to produce the three groups of injection frequencies for use in translator module 1A8, the 1.75 MHz local carrier, and the 5 MHz standard for external use. The five modules used to accomplish this are: frequency standard module 1A3, frequency divider module 1A6, 10 and 1 kHz synthesizer module 1A4, 100 kHz synthesizer module 1A2, and MHz synthesizer module 1A9. These five modules operate during both receive and transmit operation. In the RT-834/GRC an additional module the 100 Hz synthesizer module 1A1A2A8, for a total of six modules, operate during both receive and transmit operation.

1-15. Frequency Standard Module 1A3

(fig. 4-36)

a. General. Frequency standard module 1A3 produces an accurate and stable frequency reference signal which is used to generate signals of various frequencies used in operation. Frequency standard module 1A3 produces the following signal outputs: 1MHz, 5MHz, 10MHz, and 500kHz.

NOTE

Prefix all reference designators in this paragraph with the frequency standard module reference designator 1A3, unless otherwise specified.

b. 5 MHz Generation. The 5 MHz, frequency reference signal is produced by oscillator A1A1Q1. The frequency of the signal is determined by the series resonant feedback path consisting of crystal A1A1Y1 and capacitors A1A1C5 and A1A1C6. Capacitor A1A1C6 is used to tune the feedback circuit to the exact operating frequency, 5 MHz. The parallel-resonant circuit consisting of transformer A1A1T1 and capacitor A1A1C2

provides the correct load for oscillator A1A1Q1. Transformer A1A1T1 is also used to tap off the correct amount of feedback voltage needed to sustain stable oscillations. Diodes A1A1CR2 and A1A1CR3 symmetrically limit the amplitude of the 5 MHz signal to a value equal to their forward voltage drops. The output from oscillator A1A1Q1 is inductively coupled by transformer A1A1T1 to the base of buffer amplifier A1A1Q2. Buffer amplifier A1A1Q2 provides the necessary isolation for oscillator A1A1Q1, preventing adverse loading by the circuits that follow. The output from buffer amplifier A1A1Q2 is coupled by transformer A1A1T2 to INT-EXT switch A3S1. When set at INT, as shown in figure 4-31, the 5 MHz signal is coupled by capacitor A3C7 to the base of amplifier A3Q2 and also coupled by capacitor A3C5 to the base of multiply X2 A3Q1. Amplifier A3Q2 raises the level of the 5 MHz signal to make it suitable for use in mixer A2Q3 (*d* below). When switch A3S1 is set at INT, the 5 MHz output from amplifier A3Q2 is also applied through transformer A3T2, switch A3S1, and connector J1A-A2 to FREQ STD connector 1A1J22 on the front panel. This allows an accurate and stable standard to be used as a reference for other equipment. When switch A3S1 is set at EXT, a standard 5 MHz signal connected to FREQ STD connector 1A1J22 is applied through connector J1A-A2, switch A3S1, transformer A3T3, and switch A3S1 to amplifier A3Q2 and multiply X2 A3Q1. All signal outputs from frequency standard module 1A3 are then referenced to the external standard signal rather than the output from oscillator A1A1Q1 (internal standard). If the external standard signal level exceeds the predetermined value determined by voltage divider A3R9 and A3R10, diode A3CR1 will become forward-biased and conduct. Therefore, the amplitude of the external standard is prevented from exceeding the circuit requirements.

c. 10 MHz Generation. Multiply X2 A3Q1 is an amplifier that is biased for class AB operation. This results in the production of harmonics from the basic 5 MHz input signal. A double-tuned tank circuit is employed in the output circuit of multiply X2 A3Q1 to insure that only the desired 10 MHz output will pass. The selectivity of the double-tuned tank circuit is sufficient to reject the 5 MHz signal and all other harmonics above 10 MHz. The 10 MHz output from multiply X2 A3Q1 is applied through connector J1B-A2 to 100 kHz synthesizer module 1A2 (para 1-19).

d. 1 MHz Generation. Mixer A2Q3 and multiply X4 A2Q2 form a regenerative closed-loop divider that produces a locked 1 MHz output when synchronized by the 5 MHz signal. Initially, prior to application of the 5 MHz synchronizing signal, multiply X4 A2Q2 will act as an oscillator with a feedback loop through mixer A2Q3. The output from mixer A2Q3 is tuned to 1 MHz; however, it has sufficient gain at 4 MHz to sustain oscillations in multiply X4 A2Q2. This loop will then oscillate at a frequency near 4 MHz. The 5 MHz signal is coupled through capacitors A2C17, A2C16, and A2C11 to the base of mixer A2Q3. The 4 MHz output from the regenerative loop will also be coupled through capacitor A2C11 to the base of mixer A2Q3. Here these two signals are subtractively mixed, producing an output from mixer A2Q3 near 1 MHz. Multiply X4 A2Q2 is biased for class AB operation, resulting in the production of harmonics from the basic 1 MHz input signal. The output tank circuit for multiply X4 A2Q2 will pass the 4 MHz harmonic and has sufficient selectivity to reject all other harmonics above and below 4 MHz, including the 1 MHz basic frequency input. The 4 MHz signal is then mixed with the 5 MHz signal. The flywheel effect of this regenerative closed-loop divider will eliminate any error in the 1 MHz signal output, resulting in a stable 1 MHz signal output, locked to the 5 MHz frequency reference signal. Capacitors A2C16 and A2C17 form an attenuator, preventing the 1 MHz signal from getting back onto the 5 MHz input line. The 1 MHz output from mixer A2Q3 is coupled by transformer A2T3 to connector J1B-A1 for application to MHz synthesizer module 1A9 (para 1-18). A portion of the 1 MHz output from mixer A2Q3 is taken from a tap on the primary of transformer A2T3 and is coupled through capacitor A2C15 to transformer A2T1 (*e* below).

e. 500 kHz Generation. Mixer A2Q1 is a regenerative closed-loop divider circuit, the output of which is 500 kHz. The 1 MHz output from mixer A2Q3 (*d* above) is coupled through one of the secondary windings of transformer A2T1 and capacitor A2C3 to the base of mixer A2Q1. The collector load for mixer A2Q1 is a 500 kHz tuned-tank circuit consisting of the primary of transformer A2T1 and capacitor A2C2. The initial application of the 1 MHz signal causes mixer A2Q1 to generate energy at 500 kHz. The 500 kHz portion of this energy is amplified and passed by the tuned-tank circuit. This 500 kHz output is then mixed with the 1 MHz input to transformer A2T1

in mixer A2Q1, producing additional 500 kHz drive to the base of mixer A2Q1. The flywheel effect of this regenerative loop will then produce a stable 500 kHz output, locked to the 5 MHz frequency reference signal. The 500 kHz output from mixer A2Q1 is coupled by transformer A2T1 to connector J1A-A1 for application to frequency divider module 1A6 (para 1-16). Capacitor A2C15 reduces the possibility of the 500 kHz signal getting back to the 1 MHz line.

f. Proportional Oven Control Circuit. The proportional oven control circuit is specifically designed to maintain crystal A1A1Y1, oscillator A1A1Q1, and buffer amplifier A1A1Q2 at a constant ambient temperature of 85° C. (185° F.). When the SERVICE SELECTOR switch is at OVEN-ON, +27 volts dc is applied through thermal switches A1S1 and A1S2 to heating element A1R2. The resulting current flow through heating element A1R2 causes the oven to heat up rapidly to approximately 78° C., at which time, thermal switch A1S1 will open. At this time, the temperature is controlled by the bridge consisting of the secondary of transformer A1A2T1, thermistor A1R3, and resistors A1A2R6 and A1A2R7. The sensing element of this bridge, thermistor A1R3, detects the difference between 70° C. and 85° C., and applies a positive feedback signal proportional to the unbalance in the circuit to the base of buffer amplifier A1A2Q1. Buffer amplifier A1A2Q1 applies this positive feedback to oscillator A1A2Q2, thereby determining its output signal level. The primary of transformer A1A2T1 and capacitor A1A2C3 forms the tank circuit for oscillator A1A2Q2. The output from oscillator A1A2Q2 is coupled from a tap on the primary of transformer A1A2T1 by capacitors A1A2C5 and A1A2C8 to the base of detector-driver A1A2Q3. Thermistor A1A2R13 compensates for ambient temperature changes in order to maintain the correct input levels to detector-driver A1A2Q3. Diode A1A2CR2 protects detector-drive A1A2Q3 against excessive reverse bias on the base-to-emitter junction. Resistors A1A2R11 and A1A2R12 form a voltage divider to supply negative dc bias to the base of detector-driver A1A2Q3. This tends to stabilize the gain of detector-driver A1A2Q3 as the ambient temperature varies. The output from detector-driver A1A2Q3 drives power amplifier A1Q1 on, causing a current flow through heating elements A1R1 and A1R2, which is proportional to the unbalance of the temperature bridge. As the temperature of oven assembly A1 increases, the amount of positive feedback to oscillator A1A2Q2 decreases,

and proportionally, the conduction rate of detector-driver A1A2Q3 and power amplifier A1Q1 decreases. When the temperature of the circuit reaches 85° C., the temperature bridge will hold the output from oscillator A1A2Q2 constant. This will maintain a constant current flow through heating elements A1R1 and A1R2, holding the oven temperature at a nearly constant 85° C. If the temperature of the circuit drops below 85° C., the temperature bridge will again be unbalanced and the temperature will be brought back to 85° C. If for some reason the temperature-sensing circuit failed, the temperature of the circuit could continue to increase. To prevent damage to the transistors from overheating, thermal switch A1S2 will open at approximately 90° C. and remove operating voltage to detector-driver A1A2Q3 and power amplifier A1Q1. At the time of initial turn on, the base of power amplifier A1Q1 will be at approximately 27 volts dc. Diode A1A2CR2 is used to prevent this voltage from reverse-biasing the emitter-to-base junction of detector-driver A1A2Q3, preventing the stage from being damaged.

1-16. Frequency Dividers Module 1A6

(fig. 4-40)

a. General. Frequency dividers module 1A6 produces three spectrum outputs, for use in 100 kHz synthesizer module 1A2 (para 1-19), and 10 and 1 kHz synthesizer module 1A4 (para 1-17). This module also produces a spectrum output for cw operation (para 1-6c) and the 1.75 MHz local carrier (para 1-6e and 1-12c and f).

NOTE

Prefix all reference designators in this paragraph with the frequency dividers module reference designator 1A6, unless otherwise specified.

b. 100 kHz Divider Circuit. The 100 kHz divider circuit provides the spectrum of frequencies used in 100 kHz synthesizer module 1A2 (para 1-19). This circuit also produces the trigger pulses for the 10 kHz divider circuit (*c* below).

(1) The input to the 100 kHz divider circuit is the 500 kHz output from frequency standard module 1A3 (para 1-15e). This sinusoidal signal is applied to autotransformer A1T1, where it is stepped up and coupled by capacitor A1C4 to the base of pulse shaper A1Q1. The negative portions of the 500 kHz signal are of sufficient magnitude to drive pulse shaper A1Q1 into sat-

uration. This results in the collector of pulse shaper A1Q1 being effectively switched between zero and the supply voltage level. Diode A1CR1 provides temperature compensation for pulse shaper A1Q1 and aids in the shaping of the output pulses. The positive pulsed output from pulse shaper A1Q1 is differentiated by capacitor A1C5 and the input impedance of astable multivibrator A1Q2, A1Q3.

(2) Multivibrator A1Q2, A1Q3 is an astable (free-running) multivibrator until synchronized by the 500 kHz trigger pulses. Assume that a positive trigger pulse is applied to the base of transistor A1Q2 and that both transistors A1Q2 and A1Q3 are cut off. The collector of transistor A1Q2 and the base of transistor A1Q3 are at the supply voltage level (7.5 volts dc) at this time. The input pulse will forward-bias transistor A1Q2, causing it to conduct. The resulting collector current develops a voltage drop across resistor A1R4, decreasing the base bias of transistor A1Q3. Since the emitter of transistor A1Q3 is at the supply voltage level, A1Q3 will become forward-biased and conduct. This causes the collector of A1Q3 to go from zero to approximately 6.5 volts dc. (The 1 volt drop would be caused by the small forward resistance of diodes A1CR3 and the emitter-to-collector resistance of transistor A1Q3.) The base-bias voltage divider for transistor A1Q2 (resistors A1R5, A1R6, A1R7) will have 6.5 volts dc (transistor A1Q3 collector voltage) on one end and the 7.5 volt dc supply on the other end. This causes A1Q2 to go too and be held at saturation. Therefore, A1Q2 and A1Q3 are both conducting at saturation. Capacitor A1C7 now charges through two paths. One path is through resistor A1R21, transistor A1Q2, and resistor A1R4. The other path is through resistor A1R8, transistor A1Q3, and diode A1CR3. As the charge on capacitor A1C7 increases, the emitter bias on transistor A1Q2 increases, decreasing the forward bias. This reduces the collector current of transistor A1Q2, causing the collector to go positive. Therefore, the base bias on transistor A1Q3 will go positive, decreasing the forward bias. This decreases the collector current of transistor A1Q3, decreasing the amount of bias applied to the base of transistor A1Q2 by base-bias voltage divider A1R5, A1R6, A1R7. This further reduces the forward bias of transistor A1Q2. The resulting regeneration brings transistors A1Q2 and A1Q3 out of saturation and continues until they are both cut off. Capacitor A1C7 now starts the discharge through resistors A1R10, A1R9, and A1R8. During the start of the discharge

period, the trigger pulses are still applied to the base of transistor A1Q2, but are not of sufficient magnitude to turn it on. When transistors A1Q2 and A1Q3 are cutoff, the base bias on transistor A1Q2 is determined by voltage divider A1R5, A1R6, A1R7, A1R9, A1R10. The emitter voltage is the charge on capacitor A1C7. Therefore, capacitor A1C7 has to discharge to such a value that when a positive trigger pulse is applied to the base of transistor A1Q2, it starts to conduct. The time constant of the rc network consisting of capacitor A1C7 and resistors A1R8, A1R9, A1R10 is fixed so that resistor A1R5 can be adjusted to set the bias on the base of transistor A1Q2 to allow every fifth pulse, after the initial trigger pulse, to turn transistor A1Q2 on. When this occurs, the collector voltage on transistor A1Q2 will again decrease, and the regeneration process will be repeated. Thus, the process of regeneration occurs before the natural period has been completed as a result of the application of every fifth trigger to the base of transistor A1Q2. This results in an output (at the collector of transistor A1Q3) that is exactly one-fifth the input trigger pulse rate. The resulting 100 kHz signal present at the collector of transistor A1Q3 is applied to the 10 kHz divider circuit (*c* below). Capacitor A1C10 prevents any degeneration from occurring in the circuit as a result of the small forward resistance of diode A1CR3. Capacitor A1C8 speeds up the application of the pulses from the collector of transistor A1Q3 to base of transistor A1Q2. The 100 kHz pulsed output from transistor A1Q3 is developed across voltage divider A1R9, A1R10 and is coupled by capacitor A1C11 to the base of pulse amplifier A1Q4.

(3) Pulse amplifier A1Q4 and keyed oscillator A1Q5 form a keyed oscillator circuit that will produce a sinusoidal burst (spectrum) of frequencies. During the off time of astable multivibrator A1Q2, A1Q3, pulse amplifier A1Q4 is forward-biased and conducts to saturation. When pulse amplifier A1Q4 is conducting, the small emitter-to-collector resistance will heavily load the tank circuit (capacitor A1C13 and the primary of transformer A1T2) of keyed oscillator A1Q5, preventing regeneration. When a positive pulse is coupled to the base of pulse amplifier A1Q4, it will become reverse-biased and cut off for the duration of the pulse. This removes the load from the tank circuit of oscillator A1Q5, permitting it to oscillate at its natural frequency. Resistor A1R16 helps turn off keyed oscillator A1Q5 by increasing the voltage on the collector of keyed oscillator A1Q5 when pulse amplifier

A1Q4 is conducting at saturation. When the load created by the conduction of pulse amplifier A1Q4 is removed from the tank circuit of keyed oscillator A1Q5, the tank circuit will produce a sinusoidal burst of frequencies. This results in a spectrum of frequencies between 15.3 and 16.2 MHz centered around the free-running frequency of oscillator A1Q5. These frequency bursts are separated by the 100 kHz keying rate. This frequency spectrum is coupled by transformer A1T2 to connector J1A-A4 for application to 100 kHz synthesizer module 1A2 (para 1-19).

c. 10 kHz Divider Circuit. The 10 kHz divider circuit produces one of the spectrums of frequencies used in 10 and 1 kHz synthesizer module 1A4 (para 1-17). This circuit also produces the triggering pulses for the 1 kHz divider circuit (*d* below), the 1.75 MHz generator (*e* below), and the vernier frequency capabilities.

(1) The input to the 10 kHz divider circuit is the 100 kHz triggering pulse from the 100 kHz divider circuit (*b* above). This pulsed signal is differentiated by capacitor A2C2 and the input impedance of bistable multivibrator A1Q1, A2Q2. Bistable multivibrator A2Q1, A2Q2 produces one output pulse for every two input pulses. The positive pulses are directed to the saturated transistor of multivibrator A2Q1, A2Q2 by steering diodes A2CR1 and A2CR2. This turns off the saturated transistor and starts the required regenerative process. Resistor A2R2 references the anodes of steering diodes A2CR1 and A2CR2 at the same potential as the emitters of transistors A2Q1 and A2Q2 and provides the return path for capacitor A2C2. The resulting 50 kHz pulsed output is developed across voltage divider A2R6, A2R9 and is coupled by capacitor A2C11 to the 1.75 MHz generator (*e* below). The 50 kHz pulsed output from bistable multivibrator A2Q1, A2Q2 is also developed across resistor A2R10 and is applied to astable multivibrator A2Q3, A2Q4.

(2) The 50 kHz pulsed signal is differentiated by capacitor A2C6 and the input impedance of astable multivibrator A2Q3, A2Q4. Astable multivibrator A2Q3, A2Q4 functions the same as astable multivibrator A1Q2, A2Q3 (*b* above) to produce a 10 kHz pulsed output across voltage divider A2R16, A2R17. This 10 kHz pulsed output is applied to the 1 kHz divider circuit (*d* below) and is coupled by capacitor A2C20 to the base of pulse amplifier A2Q7.

(3) When the FREQ VERNIER control is at OFF, pulse amplifier A2Q7 and keyed oscillator A2Q8 function as a keyed oscillator the same as pulse amplifier A1Q4 and keyed oscillator

A1Q5 (*b* above). This circuit produces a spectrum of frequencies between 2.48 and 2.57 MHz which are separated by the 10 kHz keying rate. The spectrum output from the keyed oscillator is coupled by transformer A2T3 to connector J1B-A1 for application to 10 and 1 kHz synthesizer 1A4 (para 1-17).

(4) When the *FREQ VERNIER* control is in an on position, keyed oscillator A2Q8 functions as an amplifier. The feedback path for keyed oscillator A2Q8 is through transformer A2T3, capacitor A2C25, diode A2CR8, and capacitor A2C27. When the *FREQ VERNIER* control is placed in the on position, 20 volts dc is applied through pin 1 of connector J1A, decoupling network A2L3, A2R40, and resistor A2R37 to the anode of diode A2CR9. This will forward-bias diode A2CR9, applying approximately 15 volts dc to the cathode of diode A2CR8. Since the anode bias on diode A2CR8 is only 9 volts dc (as determined by voltage divider A2R44, A2R34, A2R33), diode A2CR8 will be reverse-biased. This will then block the feedback path of keyed oscillator A2Q8, preventing it from functioning as an oscillator. The output from oscillator A2Q9 will then be gated to the keyed oscillator (amplifier) A2Q8 by pulse amplifier A2Q7 at the 10 kHz keying rate. The resonant circuit for oscillator A2Q9 consists of 2.53 MHz crystal A2Y2, inductor A2L2, and voltage variable capacitor A2CR10. The center point of vvc A2CR10 is set by the dc voltage level established by temperature-compensated voltage divider A2R47, A2R50, A2R48, A2R43, A2R49, and the *FREQ. VERNIER* control on the front panel. Resistor A2R49 provides adjustment to compensate for difference in the voltage variable capacitors used. The wiper of the *FREQ. VERNIER* control is connected to pin 2 of connector J1A, and one end of the control is connected to pin 4 of connector J1A. The other end of the *FREQ. VERNIER* control goes through a temperature-compensating network to 20 volts dc (fig. 4-33). This allows the voltage at pin 2 of connector J1A to be varied above and below the reference point established by the 20 volts dc on pin 1 of connector J1A. Therefore, the resonance of the tank circuit may be varied plus or minus 600 Hz. Since the capacity of a vvc varies nonlinearly with voltage, resistor A2R43 is placed from the wiper to one end of the *FREQ. VERNIER* control to make it nonlinear. The value of resistor A2R43 is chosen to establish nonlinearity in the *FREQ. VERNIER* control. Therefore, the nonlinear voltage across resistors A2R49 and A2R43 and the *FREQ. VER-*

NIER control will cancel the nonlinearity of vvc A2CR10. Resistor A2R42 is an isolating resistor. Base bias for oscillator A2Q9 is established by voltage divider A2R39, A2R41. Capacitors A2C28 and A2C30 form the reactive voltage divider for the feedback required to sustain oscillations in oscillator A2Q9. Capacitor A2C30 is a temperature-compensating capacitor. Resistor A2R38 is the emitter current-limiting resistor. The 2.53 MHz plus or minus 600 Hz output from oscillator A2Q9 is coupled by capacitor A2C29 to the anode of diode A2CR9. Since diode A2CR9 is forward-biased in the vernier condition, the output from A2Q9 is coupled by capacitor A2C27 to the base of keyed oscillator (amplifier) A2Q8. Pulse amplifier A2Q7 will gate this signal through keyed oscillator (amplifier) A2Q8 at the kHz keying rate. This will produce the desired 2.48 to 2.57 MHz spectrum, the spectrum points of which are separated exactly by the 10 kHz keying rate, but are variable plus or minus 600 Hz depending on the setting of the *FREQ VERNIER* control. The collector of pulse amplifier A2Q7 is switched between 0 and 20 volts dc by the synchronizing signal. This switching signal is applied to the anodes of diodes A2CR5 and A2CR6. Diode A2CR7 always has 20 volts dc applied to its anode. The potential difference between anode and cathode of this reference diode (A2CR7) is approximately 1 volt dc. When the switching voltage is at 0 volt, diodes A2CR5 and A2CR6 will be reversed-biased and diode A2CR7 will be forward-biased, placing the tap of transformer A2T3 at ac ground potential. When the switching voltage is at 20 volts dc, diodes A2CR5 and A2CR6 will be forward-biased and diode A2CR7 will be reversed-biased. Diodes A2CR5 and A2CR6 (when forward biased) effectively place an ac short across the tank circuit while diode A2CR7 removes the ground at the tap of transformer A2T3. Therefore, diode A2CR7, in conjunction with diodes A2CR5 and A2CR6, prevents ringing in the tank circuit as a result of the effective switching of the ac short.

d. 1 kHz Divider Circuit. The 1 kHz divider circuit produces the signal for the 1 kHz synthesizer module 1A4 (para 1-17). This circuit also produces the 1 kHz pulse output that is used in transmitter IF and audio module 1A5 for cw keying (para 1-6c). The input to the 1 kHz divider circuit is the 10 kHz triggering pulse from the 10 kHz divider circuit (*c* above). The pulsed signal is differentiated by capacitor A3C2 and the input impedance of bistable multivibrator A3Q1, A3Q2. Bistable multivibrator A3Q1, A3Q2 func-

tions exactly like bistable multivibrator A2Q1, A2Q2 (*c* above) to divide the 10 kHz pulsed input by two. The 5 kHz pulsed output from bistable multivibrator A3Q1, A3Q2 is differentiated by capacitor A3C6 and the input impedance of astable multivibrator A3Q3, A3Q4. Astable multivibrator A3Q3, A3Q4 functions exactly like astable multivibrator A1Q2, A1Q3 (*b* above) by dividing the 5 kHz pulsed signal by five. The resulting 1 kHz pulsed output is required in the 10 and 1 KHz synthesizer module 1A4. This is applied to 10 and 1 KHz synthesizer module 1A4 through connector J1A-A1 (para 1-17). The 1 kHz pulse output is also applied through resistor A3R18 to connector J1A-A2 to the 2 kHz generator for cw operation (para 1-6*c*).

e. 1.75 MHz Generator. The 1.75 MHz local carrier is used in transmitter IF and audio module 1A5 (para 1-6*e*) and receive IF module 1A7 (para 1-2*c* and *f*). The input to the 1.75 MHz generator is 50 kHz pulsed output from the 10 kHz divider circuit (*c* above). This signal is applied to a keyed oscillator circuit consisting of pulse amplifier A2Q5 and keyed oscillator A2Q6. This keyed oscillator circuit functions exactly like the keyed oscillator circuit in the 100 kHz divider circuit (A1Q4 and A1Q5, *b* above) to produce a spectrum of frequencies centered around 1.75 MHz, which are separated by the 50 kHz keying rate. The keying synchronizes the 1.75 MHz free-running frequency of oscillator A2Q6, insuring that the exact 1.75 MHz output is always present in the spectrum. The spectrum output from the keyed oscillator circuit is filtered by crystal A2Y1, allowing only the 1.75 MHz spectrum point to be developed across the tank circuit consisting of capacitor A2C19 and the primary of transformer A2T2. Capacitor A2C16 provides a means of adjusting the series impedance to the applied spectrum and thereby, the amplitude of the spectrum. The circuit consisting of crystal A2Y1, capacitors A2C18 and A2C19, and transformer A2T2 forms a filter for the 1.75 MHz signal. Capacitor A2C18 is adjusted so that the impedance of capacitor A2C18 and the bottom half of the primary of transformer A2T2 equals the impedance of the holder signal by five. The resulting 1 kHz pulsed output contains the required 21 to 30 kHz harmonics that are required in 10 and 1 kHz synthesizer module 1A4. This is the primary of transformer A2T2, will be of the same amplitude, but 180° out of phase with each other. This prevents any signal except the desired one from appearing in the 1.75 MHz output.

1-17. 10 and 1 kHz Synthesizer Module 1A4 (fig. 4-37)

a. General. The 10 and 1 kHz synthesizer module 1A4 produces a band of frequencies, in 1 kHz steps, between 4.551 and 4.650 MHz for injection into translator module 1A8 (para 1-7). This module also produces a 7.1 MHz output in which the frequency errors of the two oscillators are incorporated for application to 100 Hz synthesizer module 1A2 (para 1-19) to complete an error cancellation loop (para 1-21).

NOTE

Prefix all reference designators in this paragraph with 10 and 1 kHz synthesizer module reference designator 1A4, unless otherwise specified.

b. Injection Frequency Generation. The 4.551 to 4.650 MHz band of injection frequencies is produced by mixing the output from oscillator A1Q2 with the output from oscillator A1Q8.

(1) Crystal oscillator A1Q2 produces any 1 of 10 frequencies between 6.50 and 6.59 MHz, in 10 kHz steps. The frequency produced is determined by the selection of 1 of 10 crystals (A3Y1 to A3Y10) using the 10 KC or (kHz) switch A3S1, on the front panel of the receiver-transmitter. The output from oscillator A1Q2 is limited by diodes A1CR1 and A1CR2. A small reverse bias is applied to these diodes by resistors A1R2 and A1R3 to maintain a higher crystal Q over the environmental range. The output from oscillator A1Q2 is coupled by capacitor A1C4 to the base of mixer A1Q5 and is coupled by capacitor A1C6 to the base of isolation amplifier A1Q4.

(2) Crystal oscillator A1Q8 produces any 1 of 10 frequencies between 1.940 and 1.949 MHz in 1 kHz steps. The frequency produced is determined by the selection of 1 of 10 crystals (A4Y1 to A4Y10) using the 1 KC or (kHz) switch A4S2 on the front panel of the unit. The output from oscillator A1Q8 is limited by diodes A1CR8 and A1CR9. Diodes A1CR8 and A1CR9 are slightly reversed-biased by the voltage from voltage divider A1R34, A1R35 to maintain a higher crystal Q over the environmental range. The output from oscillator A1Q8 is coupled by capacitor A1C3 to the base of keyed amplifier-spectrum generator A1Q3 and by capacitor A1C22 to the base of emitter follower A1Q7. Voltage divider A1R30, A1C25 provides a low impedance to the output from oscillator A1Q8 and a high impedance to 1 kHz feedback from keyed amplifier-spectrum generator A1Q3 to minimize the amount of 1 kHz

pulses appearing in the 10 and 1 kHz output. The output from emitter follower A1Q7 is coupled by capacitor A1C14 to the emitter of mixer A1Q5. Emitter follower A1Q7 prevents oscillator A1Q8 from being loaded by mixer A1Q5.

(3) The 1.940 to 1.949 MHz signal is subtractively mixed with the 6.59 to 6.50 MHz signal in mixer A1Q5 to produce the 4.551 to 4.650 MHz band of injection frequencies. The output circuit for mixer A1Q5 is a triple-tuned bandpass filter. The filter passes only the difference between the 6.59 to 6.50 MHz and 1.940 to 1.949 MHz signals (4.551 to 4.650 MHz in 1 kHz steps). The filter has a bandwidth slightly greater than 100 kHz to allow for temperature drift of the filter, but has sufficient selectivity to attenuate any frequency outside of the bandpass. Capacitors A1C13 and A1C12 are integral parts of the filter and couple the signal between the sections of the filter. The output from the triple-tuned bandpass filter is coupled by transformer A1T2 to connector J1B-A3 for application to translator module 1A8 (para 1-7).

c. 7.1 MHz Generation. The 7.1 MHz signal is produced by mixing a 9.07 MHz signal with a 1.97 MHz signal. The 9.07 MHz signal is produced by mixing the output from oscillator A1Q2 with a 10 kHz spectrum point from frequency dividers module 1A6 (para 1-16). The 1.97 MHz signal is produced by mixing the output signal from oscillator A1Q8 with one of the harmonics of the 1 kHz pulse output from frequency dividers module 1A6 (para 1-16). Therefore, the 9.07 MHz signal and the 1.97 MHz signal will contain the error of their respective oscillator. These errors will be contained in the 7.1 MHz signal.

(1) The output from oscillator A1Q2 is coupled by capacitor A1C6 to the base of isolation amplifier A1Q4. The output from isolation amplifier A1Q4 is developed across the LC tank circuit consisting of inductor A1L3 and capacitor A1C24, from which it is coupled by capacitor A2C1 to the base of mixer A2Q1. The output level from isolation amplifier A1Q4 is such that it will not affect the conversion gain of mixer A2Q1; therefore, the tuning of tank circuit A1L3, A1C24 is not critical. Isolation amplifier A1Q4 prevents mixer A2Q1 from loading oscillator A1Q2 and also prevents any of the 10 kHz spectrum from appearing in the 10 and 2 kHz output. The 10 kHz spectrum output from frequency dividers module 1A6 (para 1-16) is applied to connector J1A-A1. From there it is coupled by capacitor A2C3 to the emitter of mixer A2Q1. The 6.59 to 6.50 MHz output from oscil-

lator A1Q2 is additively mixed with the 10 kHz spectrum (2.48 to 2.57 MHz). The output circuit for mixer A2Q1 is tuned to 9.07 MHz, attenuating some of the other mixing products. The 9.07 MHz signal is applied to filter A2FL1 to attenuate (more than 60 dB) all mixing products except the desired 9.07 MHz. The 9.07 MHz output from filter A2FL1 is coupled by capacitor A2C8 to the base of mixer A2Q2.

(2) The 1 kHz pulsed output from frequency dividers module 1A6 is applied to connector J1A-A2. From there it is coupled by capacitor A1C30 to the base of pulse amplifier A1Q1. With no pulse input, pulse amplifier A1Q1 is biased into saturation. The positive portions of the 1 kHz pulsed input will drive pulse amplifier A1Q1 into cutoff. This effectively switches the collector of pulse amplifier A1Q1 from 20 to 0 volt at a 1 kHz rate. This pulsed output is used to gate keyed amplifier-spectrum generator A1Q3 on and off at the 1 kHz keying rate. The output from keyed amplifier spectrum generator is tuned to 1.97 MHz. The output from oscillator A1Q8 (1.940 to 1.949 MHz) is additively mixed in the primary of transformer A1T1 with the harmonic of the 1 kHz pulsed input (21 to 30 kHz) that will produce a 1.97 MHz output. Diodes A1CR3 and A1CR4 provide a complete ac short across the primary of transformer A1T1 (while in the forward-biased condition) at the 1 kHz keying rate. Diode A1CR5 is used to place the top of transformer A1T1 at ac ground potential and to reference the tuned circuit at the dc supply voltage, thereby preventing the tuned circuit from ringing as the ac short is switched in and out of the tuned circuit. The output from keyed amplifier-spectrum generator A1Q3 is tuned for 1.97 MHz to attenuate some of the other mixing products. This signal is applied to filter A2F12, which attenuates (more than 60 dB) all the spectrum points except the desired 1.97 MHz. The 1.97 MHz output from filter A2FL2 is coupled by capacitor A2C8 to the base of mixer A2Q2.

(3) Mixer A2Q2 subtractively mixes the 1.97 MHz signal with the 9.07 MHz signal to produce the desired 7.1 MHz output. The output from mixer A2Q2 is coupled by capacitor A2C11 to the base of amplifier A2Q3. The gain of mixer A2Q2 is controlled by the agc voltage applied to resistor A2R7 ((4) below). Amplifier A2Q3 raises the 7.1 MHz signal to a level suitable for use in 100 KHz synthesizer module 1A2 (para 1-19). The output from amplifier A2Q3 is coupled by transformer A2T3 to connector J1B-A1.

(4) The output from amplifier A2Q3 is coupled by capacitor A2C15 to the base of amplifier A2Q4. Amplifier A2Q4 raises the level of the 7.1 MHz signal and develops it across the tuned-tank circuit. The base of detector-dc amplifier A2Q5 is referenced near the supply voltage level by diode A2CR1, thereby controlling the biasing of detector-dc amplifier A2Q5. When the 7.1 MHz signal swings positive, diode A1CR1 conducts more, causing the base-to-emitter junction of detector-dc amplifier A2Q5 to be even more dc reversed-biased. When the 7.1 MHz signal swings negative, diode A1CR1 conducts less, forward-biasing detector-dc amplifier A2Q5. The 7.1 MHz signal will be half-wave rectified by detector-dc amplifier A2Q5, filtered by capacitors A2C20 and A2C22, and applied to resistor A2R7 to control the gain of mixer A2Q2. The output level of the 7.1 MHz signal is determined by the amount of forward bias on detector-dc amplifier A2Q5. This closed-loop circuit will stabilize and insure a constant 7.1 MHz output from mixer A2Q2. Resistor A2R18 provides a dc path for A2CR1. Capacitor A2C18 is the bypass for resistor A2R18. Resistor A2R17 is used to adjust the load for the secondary of transformer A2T4 and the amount of signal to be detected, thereby adjusting the output level of the 7.1 MHz signal.

1-18. MHz Synthesizer Module 1A9

(fig. 4-43)

a. General. MHz synthesizer module 1A9 produces a band of mixing frequencies, in 1 MHz steps, between 2.5 and 23.5 MHz for injection into translator module 1A8 (para 1-7). The MHz synthesizer module also produces the hi/lo information for 100 kHz synthesizer module 1A2 (para 1-19) and translator module 1A8 (para 1-7).

NOTE

Prefix all reference designators in this paragraph with MHz Synthesizer module reference designator 1A9, unless otherwise specified.

b. Injection Frequency Generation. The 2.5 to 23.5 MHz band of injection frequencies is produced by oscillator A3Q1, A3Q2. The frequency output from oscillator A3Q1, A3Q2 is determined by 1 of 17 crystals (A4Y1 through A4Y17), which are automatically switched into the circuit by the digital tuning circuit (para 1-23d) according to the setting of the frequency controls on the front panel. Due to the wide range of fre-

quencies used, it is necessary to switch a capacitor (A5C1 through A5C17) for each crystal into the feedback network in order to produce a uniform output level. The selected capacitor and capacitor A3C6 form a reactive voltage divider. The signal at the output of oscillator A3Q1, A3Q2 is applied back to this divider through resistor A3R15 and thermistor A3R17. Thermistor A3R17 compensates the amount of feedback as the temperature changes. The output from oscillator A3Q1, A3Q2 is limited to the forward voltage drop of diodes A3CR2 and A3CR3. The output from oscillator A3Q1, A3Q2 is locked to the exact frequency required by voltage variable capacitor (vvc) A3CR1. The dc control voltage for vvc A3CR1 is the output voltage from dc amplifier A2Q3 (*b* below). The complete feedback path for oscillator A3Q1, A3Q2 consists of the selected crystal (A4Y1 through A4Y17), vvc A3CR1, capacitors A3C4, A3C10, A3C6, and the selected capacitor (A5C1 through A5C17), resistor A3R15, and thermistor A3R17. Capacitor A3C4 is a temperature-compensating capacitor, providing compensation for variations in crystal frequency as the temperature varies. Capacitor A3C10 allows the capacity of the feedback circuit to be adjusted to compensate for the variations in the tolerances of the vvc used in the circuit. The output from oscillator A3Q1, A3Q2 is coupled by capacitor A3C8 to isolation amplifier A2A1Q1 and emitter follower A3Q3. Emitter follower A3Q3 prevents the circuit of translator module 1A8 from loading the output from oscillator A3Q1, A3Q2. The output from emitter follower A3Q3 is coupled by capacitor A3C9 to connector J1A2 for application to translator module 1A8 (para 1-7).

c. Phase Lock Loop. The phase lock loop generates a dc voltage proportional to the frequency error of oscillator A3Q1, A3Q2. This dc voltage is applied to vvc A3CR1 to maintain the oscillator output at the exact frequency required.

(1) The 1 MHz output from frequency standard module 1A3 (para 1-15) is applied to connector J1A1, from which it is applied through resistor A1R2 to autotransformer A1T1. Resistor A1R2 prevents loading of the 1 MHz input signal. The level of the 1 MHz signal is stepped up by autotransformer A1T1, which is tuned to 1 MHz by capacitor A1C1, and is applied to a clipper circuit consisting of diode A1CR2 and resistor A1R3. The positive portion of the 1 MHz signal is removed and the resulting negative pulses are coupled by capacitor A1C3 to the base of pulse amplifier A1Q1. The negative-going pulses

drive pulse amplifier A1Q1 into saturation, producing a positive-going pulse with a fast risetime at the collector of pulse amplifier A1Q1. If the base of pulse amplifier A1Q1 attempts to go more positive than the emitter, diode A1CR3 will become forward-biased. This clamps the base voltage, preventing excessive reverse bias on the base-to-emitter junction of pulse amplifier A1Q1. The positive pulsed output from pulse amplifier A1Q1 is coupled by capacitor A1C4 to the base of pulse shaper A1Q2, driving it into saturation. The positive pulsed input to pulsed shaper A1Q2 is differentiated by capacitor A1C4 and the input impedance to pulse shaper A1Q2. Capacitor A1C6 is used to compensate for frequency roll-off at the higher frequencies to maintain a uniform spectrum output from pulse shaper A1Q2. The negative pulsed output from pulse shaper A1Q2 is coupled to the base of pulse shaper A1Q3 by capacitor A1C8. The negative pulsed input to pulse shaper A1Q3 is differentiated by capacitor A1C8 and the input impedance of pulse shaper A1Q3. The shape of the waveform is determined mainly by the value of capacitor A1C8. Pulse shaper A1Q3 is a class C amplifier which produces a sharp amplifier output pulse. Diode A1CR4, like diode A1CR3, is used as a protective device to clamp the positive portions of the input signal. The positive-going output signal is developed across inductor A1L1. The value of inductor A1L1 is chosen so that the output signal will have the correct bandwidth and amplitude from 1 to 25 MHz. The negative portions of the output signal are removed by the clipping circuit, consisting of diode A1CR5 and resistor A1R17. The positive pulsed output from pulse shaper A1Q3 is coupled by capacitor A2C2 to the base of mixer A2Q1.

(2) The output from oscillator A3Q1, A3Q2 is coupled by capacitor A2A1C1 to the input of isolation amplifier A2A1Q1. The output of isolation amplifier A2A1Q1 is coupled by capacitor A2C3 to the base of mixer A2Q1. Isolation amplifier A2A1Q1 prevents any of the pulsed output from pulse shaper A1Q3 from being fed back to oscillator A3Q1, A3Q2 and producing unwanted spurious signals. The double-tuned output circuit (transformer A2T1, capacitor A2C6 and transformer A2T2, capacitor A2C8) for mixer A2Q1 is tuned to 1.5 MHz. Therefore, the oscillator output will be subtractively mixed in mixer A2Q1 with those two spectrum points of the pulsed output pulse shaper A1Q3 that will produce two tones close to 1.5 MHz. This results

in a two-tone output from mixer A2Q1, the envelope of which is varying by twice the error of the output from oscillator A3Q1, A3Q2. To make this more understandable, assume that the input from oscillator A3Q1, A3Q2 should be 2.500000 MHz, but is 2.500100 MHz (100 hertz error). This signal will be mixed with the 1 MHz and 4 MHz spectrum points, resulting in two tones: 1.500100 MHz and 1.499900 MHz. Therefore, the envelope of the two-tone signal will be varying at a 200 hertz rate. The output from mixer A2Q1 is coupled by capacitor A2C7 to another tuned circuit (A2T2, A2C8), which in combination with the tuned output of mixer A2Q1, provides the selectivity required to attenuate all mixer products of mixer A2Q1, except those at or near 1.5 MHz. The output from this tuned circuit is coupled by capacitor A2C12 to the base of IF amplifier A2Q2. A small amount of degeneration, to stabilize the gain of IF amplifier A2Q2, is provided by the temperature-compensated network consisting of resistor A2R11 and thermistor A2R21. The output from IF amplifier A2Q2 is developed across the tuned circuit consisting of capacitor A2C15 and the primary of transformer A2T3, from which it is coupled to diode A3CR1. Diode A2CR1 envelope detects the two-tone output from IF amplifier A2Q2. Assuming the same error as before, the output from diode A1CR1 would be 200 hertz. This 200 hertz signal would be applied to the emitter of dc amplifier A2Q3. The input level to dc amplifier A2Q3 is set by resistor A2R15. Thermistor A2R20 provides temperature compensation for the base and emitter-biasing circuits. The output from dc amplifier A2Q3 is applied to vvc A3CR1. This creates a closed-loop to lock the output of oscillator A3Q1, A3Q2 at the exact output frequency required. This output is a dc level, which is varied by the error (ac) voltage. The ac output of dc amplifier A2Q3 varies the capacitance of vvc A3CR1 by varying the applied voltage about the dc reference, sweeping the frequency of oscillator A3Q1, A3Q2 accordingly. Since the loop is closed, this sweep frequency will decrease with time due to the decrease in the oscillator error as it is swept. When the error signal has been reduced to one that is within the pull-in or capture range of the oscillator, the oscillator will be locked exactly at the desired frequency. At this time, only the dc level will be applied to vvc A3CR1 to hold the oscillator in lock. If the phase of the oscillator begins to drift the dc reference on the vvc A3CR1 will shift accordingly to hold the oscillator locked to the 1 MHz reference signal. Resistors

A3R16 and A3R14 and capacitor A3C2 form a compensating network for both phase and amplitude margin. Since there will be some high-frequency rolloff of the spectrum output from pulse shaper A1Q3, the 1.5 MHz IF output from IF amplifier A2Q2 will be less at the higher spectrum frequencies than it will be at the lower spectrum frequencies. Resistor A2R15 is set to provide a maximum dc swing at the output of dc amplifier A2Q3 at the higher spectrum points. Therefore, at the lower frequencies, the output from dc amplifier A2Q3 will be clipped. The phase lock loop cannot lock oscillator A3Q1, A3Q2 for any phase differences greater than 180°. Since the two-tone output from mixer A2Q1 incorporates a 90° phase shift, the remaining networks must not have a phase shift greater than 90°. The time constant of resistors A3R14 and A3R16 and capacitor A3C2 is fixed, so that the phase shift caused by this combination will lag the phase shift of the previous circuits. This insures that the oscillator can always be locked.

d. Hi/Lo Information. The hi/lo information is generated by switch A6S1C. The position of the switch is determined by the setting of the RT-662/GRC front panel MHz controls. The MHz digit selected at the front panel determines whether a hi or lo output should be produced in order that the predetermined mixing process can be satisfied. Either 20 volts dc (lo) or ground (hi) is applied to pins 1 and 2 of connector J1 by switch A6S1C. This information is applied to 100 kHz synthesizer module 1A2 to select the correct band of frequencies (para 1-19) and to translator module 1A8 to select the corresponding filtering (para 1-7).

1-19. 100 KHz Synthesizer Module 1A2

(fig. 4-35)

a. General. The 100 kHz synthesizer module 1A2 produces two bands of frequencies, in 100 kHz steps, for injection into translator module 1A8 (para 1-7). One band is between 22.4 and 23.3 MHz and the other band is between 32.4 and 33.3 MHz.

NOTE

Prefix all reference designators in this paragraph with 100 KHz Synthesizer module reference designator 1A2, unless otherwise specified.

b. Injection Frequency Generation. The 22.4 to 23.3 MHz band of frequencies is produced by mixing the output from switched crystal oscilla-

tor A4Q1 with a 17.847 MHz signal. This 17.847 MHz signal is produced by mixing the output from switched crystal oscillator A4Q1 with a spectrum point of 100 kHz spectrum from frequency divider module 1A6 (para 1-16). The resulting product is then mixed with the 7.1 MHz output from 10 to 1 KHz synthesizer module 1A4 (para 1-17 and *c* below). The 32.4 to 33.3 MHz band of frequencies is produced by mixing the output from switched crystal oscillator A4Q1 with a 27.847 MHz signal. This 27.847 MHz signal is produced by mixing the 17.847 MHz signal (*e* below) with the 10 MHz output from frequency standard module 1A3 (para 1-15 and *d* below).

(1) Switched crystal oscillator A4Q1 produces any 1 of 10 frequencies between 4.553 and 5.453 MHz, in 100 kHz steps. The frequency produced is determined by the selection of 1 to 10 crystals (A4Y1 through A4Y10). The crystal is selected using 100 kHz ((KC or kHz) switch A4S1 on the front panel of the receiver-transmitter. The output from oscillator A4Q1 is coupled by capacitor A4C1 through resistor A2R20 to the emitter of isolation amplifier A2A1Q1. The output is also gated through diode A1CR1 or A1CR2, depending on the required band of frequencies.

(2) The gate (A1CR1 or A1CR2) through which the output from oscillator A4Q1 passes is determined by the hi/lo switching voltage. This voltage depends upon whether the hi or lo band of mixing frequencies is the required output from 100 kHz synthesizer 1A2. Zener diode A3VR1 regulates the 20 volts dc supply voltage to 10 volts dc. This dc voltage is applied to the anode of diode A1CR1 and the cathode of diode A1CR2. When the lo band of mixing frequencies is required, 20 volts dc is applied through current-limiting resistors A1R2 and A1R3 to anode of diode A1CR2 and the cathode of diode A1CR1. This will forward-bias diode A1CR2 and reverse-bias diode A1CR1. When the hi band of mixing frequencies is required, ground is effectively applied to the anode of diode A1CR2 and the cathode of diode A1CR1. This causes diode A1CR2 to be reverse-biased and diode A1CR1 to be forward-biased.

(3) When the hi band of mixing frequencies is required, diode A1CR1 is forward-biased, allowing the output from oscillator A4Q1 to pass. This signal is coupled by capacitor A1C4 to mixer A1CR4. Mixer A1CR4 consists of two matched backward diodes that form a balanced circuit with the primary of transformer A1T1.

The output from oscillator A4Q1 is mixed with the 27.847 MHz signal applied to the center tap of transformer A1T1 (*d* below), to produce a band of frequencies between 32.4 and 33.3 MHz. Mixer A1CR4 due to its balanced condition, will effectively cancel the 27.847 MHz. Most of the output from oscillator A4Q1 will be dropped across the matched backward diodes. The output from mixer A1CR4 is coupled through transformer A1T1 and capacitor A1C7 to the base of amplifier A1Q1. When the hi band of mixing frequencies is required, the ground present at the hi/lo control line is applied to resistor A1R7, terminating it. The supply voltage is applied to resistors A1R9 and A1R11. Therefore, the supply voltage will be developed across voltage divider A1R7, A1R9 to provide the proper bias for amplifier A1Q1. When the lo band of mixing frequencies is required, the hi/lo control line has 20 volts dc on it; therefore, voltage divider A1R7 A1R9 will have 20 volts dc on both ends, reverse-biasing amplifier A1Q1. Resistor A1R13 provides a small amount of degeneration to stabilize amplifier A1Q1. The mixing products from mixer A1CR4 are raised in level by amplifier A1Q1 and are applied to a triple-tuned filter circuit. The triple-tuned filter circuit has a passband from 32.4 to 33.3 MHz, eliminating all harmonic and mixing products except the desired additive product. The output from the triple-tuned filter is coupled by capacitor A1C22 to the base of amplifier A1Q3. When the hi band of mixing frequencies is required, base-biasing voltage divider A1R20, A1R21 is terminated with the ground on the hi/lo control line. When the lo band of mixing frequencies is required, 20 volts dc is present on both ends of the voltage divider to reverse-bias amplifier A1Q3. A small amount of degeneration is provided by resistor A1R27 to stabilize the operation of amplifier A1Q3. A trap circuit is placed in the emitter circuit of amplifier A1Q3 to eliminate any of the 27.847 MHz that was not canceled out by balanced mixer A1CR4 or attenuated by the triple-tuned filter. At 27.847 MHz, trap circuit A1C28, A1L4 will provide increased degeneration. The output from amplifier A1Q3 is coupled to the base wideband amplifier A1Q5.

(4) When the lo band of mixing frequencies is required, diode A1CR2 is forward-biased ((2) above), allowing the output from oscillator A4Q1 to pass. The lo band circuits are identical with the hi band circuits ((3) above), except for the switching voltages and frequencies that are used. Balanced mixer A1CR3 mixes the output from oscillator A4Q1 with the 17.847 MHz sig-

nal. The mixing products are amplified by amplifier A1Q2 and applied to a triple-tuned filter circuit that has a passband from 22.4 to 23.3 MHz. The 22.4 to 23.3 MHz output from the triple-tuned circuit is raised in level and applied through amplifier A1Q4 to wideband amplifier A1Q5. Amplifier A1Q4 has a trap circuit in the emitter to attenuate any 17.847 MHz that was not canceled out by balanced mixer A1CR3 or attenuated by the triple-tuned filter. Amplifier A1Q2 is turned on when the lo band of mixing frequencies is required, by the presence of 20 volts dc at base-bias resistor A1R5 and emitter resistor A1R10. When the hi band of mixing frequencies is required, ground is applied to both ends of the voltage divider and to emitter resistor A1R10, turning off amplifier A1Q2. When the lo band of mixing frequencies is required, 20 volts dc from the hi/lo control line is applied to resistor A1R28 to forward-bias amplifier A1Q4. When the hi band of mixing frequencies is required, ground is applied to the emitter resistor, reverse-biasing amplifier A1Q4. Diode A1CR5 protects amplifier A1Q4 from excessive base-to-emitter (reverse) bias. This is done to maintain the reverse bias on the base-to-collector junction which prevents distortion of the input signal to wideband amplifier A1Q5 when the hi band path is used.

(5) Wideband amplifier A1Q5 raises the level of 22.4 to 23.3 MHz or 32.4 to 33.3 MHz signals. The output from wideband amplifier A1Q5 is coupled by capacitor A2C1 to the base of emitter follower A2Q1. Emitter follower A2Q1 provides impedance matching between 100 kHz synthesizer module 1A2 and translator module 1A8. The output from emitter follower A2Q1 is coupled by capacitor A2C2 to connector J1A4 for application to translator module 1A8 (para 1-7).

c. 17.847 MHz Generation. The 17.847 MHz signal is produced by subtractively mixing the output from oscillator A4Q1 with the 100 kHz spectrum output from frequency dividers module 1A6. This produces a 10.747 MHz signal, which is additively mixed with the 7.1 MHz output from 10 to 1 kHz synthesizer module 1A4.

(1) The output from oscillator A4Q1 is coupled by capacitor A2A1C1 to the emitter of isolation amplifier A2A1Q1. Isolation amplifier A2A1Q1 prevents any of the spectrum frequencies at mixer A2Q4 from being applied to the other output circuit paths of oscillator A4Q1. The output from isolation amplifier A2A1Q1 is developed across transformer A2T3, from which it

is coupled by capacitor A2C18 to the base of mixer A2Q4. The 15.3 to 16.2 MHz frequency spectrum output from frequency divider module 1A6 (para 1-15) is applied to connector J1A3, from which it is coupled by capacitor A2C21 to the emitter of mixer A2Q4. Mixer A2Q4 mixes the signal from oscillator A4Q1 with each of the spectrum points. The resulting mixing products are developed across a tank circuit, consisting of capacitor A2C20 and the primary of transformer A2T2, which is tuned to 10.747 MHz. The output from the tuned circuit is filtered by crystal lattice filter A2FL1. Filter A2FL1 has enough selectivity to attenuate all adjacent 100 kHz mixer products. The output from filter A2FL1 is capacitively center-tapped to the tuned tank circuit consisting of capacitors A2C17 and A2C19 and the primary of transformer A2T1. The 10.747 MHz output is coupled by capacitor A3C20 to the base of mixer A3Q2.

(2) The 7.1 MHz output from 10 to 1 kHz synthesizer module 1A4 (para 1-17) is applied to connector J1A2, from which it is coupled by capacitor A3C17 to the emitter of mixer A3Q2. Mixer A3Q2 mixes the 10.747 MHz with the 7.1 MHz signals and develops the resulting mixing products across the tuned circuit consisting of the primary of transformer A3T4 and capacitor A3C16. This circuit is tuned to 17.847 MHz, the desired additive product. The amount of desired output from mixer A3Q2 is controlled by the dc output of the age circuit (*e* below). The base bias for mixer A3Q2 is developed by voltage divider A3R13, A3R14, A3R15 from the 20 volts dc applied to resistor A3R13 and the age voltage applied to resistor A3R14. The gain of mixer A3Q2 will vary as the base bias is varied by the age voltage.

(3) The output from mixer A3Q2 is coupled to a crystal filter circuit consisting of transformers A3T4 and A3T3, capacitors A3C13 and A3C14, and crystal A3Y2. Crystal A3Y2 is cut to be series resonant at 17.845 MHz but is warped so that it is series resonant at 17.847 MHz. Capacitor A3C14 is adjusted to balance the filter circuit the same as capacitor 1A6A2C18 (para 1-16*e*) to prevent any undesired signal from passing through the filter circuit. The output termination of the crystal filter circuit is the tuned tank consisting of the primary of transformer A3T3 and capacitor A3C13. The output of the crystal filter circuit is applied to balanced mixer A1CR3 (*b* above), and also is coupled by capacitor A3C12 to the base of mixer A3Q1.

d. 27.847 MHz Generation. The 27.847 MHz signal is produced by mixing the 17.847 MHz signal (*c* above) with the 10 MHz output from frequency standard module 1A3 (para 1-15).

(1) Mixer A3Q1 is turned on when the desired injection frequency of translator module 1A8 is in the hi band. This is accomplished by applying the ground from the hi/lo control line to resistor A3R8 to terminate it. Therefore, the 20 volts dc supply voltage will be developed across base-bias voltage divider A3R7, A3R8. If the lo band of injection frequencies is required, 20 volts dc is applied to both ends of this voltage divider, reverse-biasing mixer A3Q1, shutting it off. The 10 MHz output from frequency standard module 1A3 is applied to connector J1A1, from which it is coupled by capacitor A3C1 to the anode of diode A3CR2. If the lo band of injection frequencies is required, the 20 volts dc on the hi/lo control line will be applied through resistor A3R5 to the cathode of diode A3CR2, reverse-biasing it. This 20 volts dc is also applied through resistor A3R4 to the anode of diode A3CR1, forward-biasing it. Therefore, the 10 MHz signal will be shunted to ac ground. If the hi band of mixing frequencies is required, the hi/lo control line will apply ground to resistors A3R4 and A3R5. This will forward bias diode A3CR2 and reverse-bias diode A3CR1. Therefore, the 10 MHz signal will pass and be coupled by capacitor A3C8 to the emitter of mixer A3Q1. Mixer A3Q1 mixes the 17.847 MHz signal with 10 MHz signal and develops the resulting mixing products across the tuned circuit consisting of capacitor A3C11 and the primary of transformer A3T2. This circuit is tuned to the 27.847 MHz additive mixing product.

(2) The output from mixer A3Q1 is coupled to a crystal filter circuit consisting of transformers A3T1 and A3T2, capacitors A3C3 and A3C5, and crystal A3Y1. This circuit functions identically with the 17.847 MHz crystal filter circuit (*c* above) to provide the required 27.847 MHz output. The 27.847 MHz output from the crystal filter circuit is applied to balanced mixer A2CR4 (*b* above).

e. Age Circuit. The injection frequency output from emitter follower A2Q1 (*b* above) is coupled to the base of age amplifier A2Q3 by capacitor A2C3. Age amplifier A2Q3 raises the level of the input from emitter follower A2Q1 and develops it across inductor A2L3, which is used to adjust the difference in levels between the hi and lo bands of injection frequencies. Therefore, inductor A2L3 can be set to provide a uniform out-

put for both the lo and hi bands of mixing frequencies, or can be set to make one band higher in level than the other band. Resistor A2R8 produces degeneration to increase the bandwidth and provide additional stability for age amplifier A2Q3. The bias for dc amplifier A2Q2 is developed by the temperature-compensated voltage divider consisting of resistors A2R10, A2R13, A2R17, and A2R18 and thermistor A2R27. Diode A2CR1 will detect the negative portions of the output from age amplifier A2Q3 and charge capacitor A2C8. As the signal strength increases, the base bias on amplifier A2Q2 will become more negative, thus cutting down its rate of conduction. The output from dc amplifier A2Q2 is filtered by capacitor A2C9 to eliminate ripple and prevent any low-frequency oscillation in the age loop. As the output gain varies, the conduction of dc amplifier A2Q2 varies. This in turn controls the base bias of mixer A3Q2, and therefore, the stage gain of mixer A3Q2 (*c* above). Since this circuit forms a closed loop with all the other circuits of 100 kHz synthesizer module 1A2, the gain of all circuits will reach a steady-state condition. Therefore, the output from emitter follower A2Q1 will reach a constant value.

1-20. Frequency Scheme

a. Figure 1-3 illustrates the frequency scheme used to translate any rf signal between 2.0 MHz and 29.999 MHz to a 1.75 MHz IF or, conversely, to translate the 1.75 MHz IF to an rf signal between 2.0 MHz and 29.999 MHz.

b. The frequency conversion involves translator module 1A8, and the setting of the crystal switches in MHz Synthesizer module 1A9, 100 kHz synthesizer module 1A2, and 10 and 1 kHz synthesizer module 1A4. The frequency controls on the front panel are used to select the correct crystals in these synthesizer modules and place the hi/lo switching circuits in the correct conditions. The synthesizer modules inject the correct frequencies to the mixers in translator module 1A8. Translator module 1A8 separately mixes the three injection frequencies with the incoming received signal to produce the 1.75 MHz IF or with the 1.75 MHz IF to obtain the desired rf. As an example, assume that the kHz and MHz controls on the receiver-transmitter front panel are set at 07275 and the unit is in receive operation. The input to translator module 1A8 from RF amplifier module 1A12 is a 7.275 MHz signal. The output from MHz synthesizer module 1A9, which is the injection to the hf mixer, is 12.5

MHz and the hi/lo switching circuits are in the lo condition. The output from the hf mixer is applied to filter FL1, which passes the sum of the hf mixer outputs (19.775 MHz). This 19.775 MHz signal is now applied to the mf mixer. The mf mixer injection frequency, from 100 kHz synthesizer module 1A2, is 22.600 MHz. The output from the mf mixer is applied to filter FL3, which passes the difference between the 19.775 MHz and 22.600 MHz frequencies (2.825 MHz). The 2.825 MHz signal is applied to the LF mixer, where it is subtractively mixed with the 4.575 MHz injection frequency from 10 to 1 kHz synthesizer module 1A4. The resulting 1.75 MHz output is the operating IF signal.

c. Since the MHz and 100 and 10 kHz drive mechanisms control the tuning of rf amplifier module 1A12 as well as the injections from the synthesizer modules, any frequency between 2.0 and 29.999 MHz may be converted to the 1.75 MHz IF. In transmit, the reverse mixing takes place to convert the 1.75 MHz IF to the selected rf output.

1-21. Error Cancellation

(fig. 1-4)

a. General. Three error cancellation loops are used in the frequency synthesizing circuits of receiver-transmitter, to insure that the output frequency will be the exact frequency indicated by the setting of the frequency controls on the front panel. These error cancellation loops are explained in *b* through *d* below.

b. MHz Synthesizer Module 1A9. A phase lock loop is used to compensate for any crystal errors in the oscillator circuit of MHz Synthesizer module 1A9. How this loop functions to cancel frequency errors is explained in paragraph 1-18*c*.

c. 100 kHz Synthesizer Module 1A2. The errors in the crystals used in 100 kHz synthesizer module 1A2 are canceled through the internal loops used to produce the output frequencies. The output from 100 kHz synthesizer module 1A2 also contains the error from the crystals in 10 and 1 kHz synthesizer module 1A4. For simplicity of discussion, assume the 7.1 MHz output from 10 and 1 kHz synthesizer module 1A4, has no error, and that the output from crystal oscillator A4Q1 in 100 kHz synthesizer module 1A2 should be 4.553 MHz but is 4.5533 MHz (300 hertz high). Also, assume that the required output from 100 kHz synthesizer module 1A2 is 22.400 MHz. An output from oscillator A4Q1 is

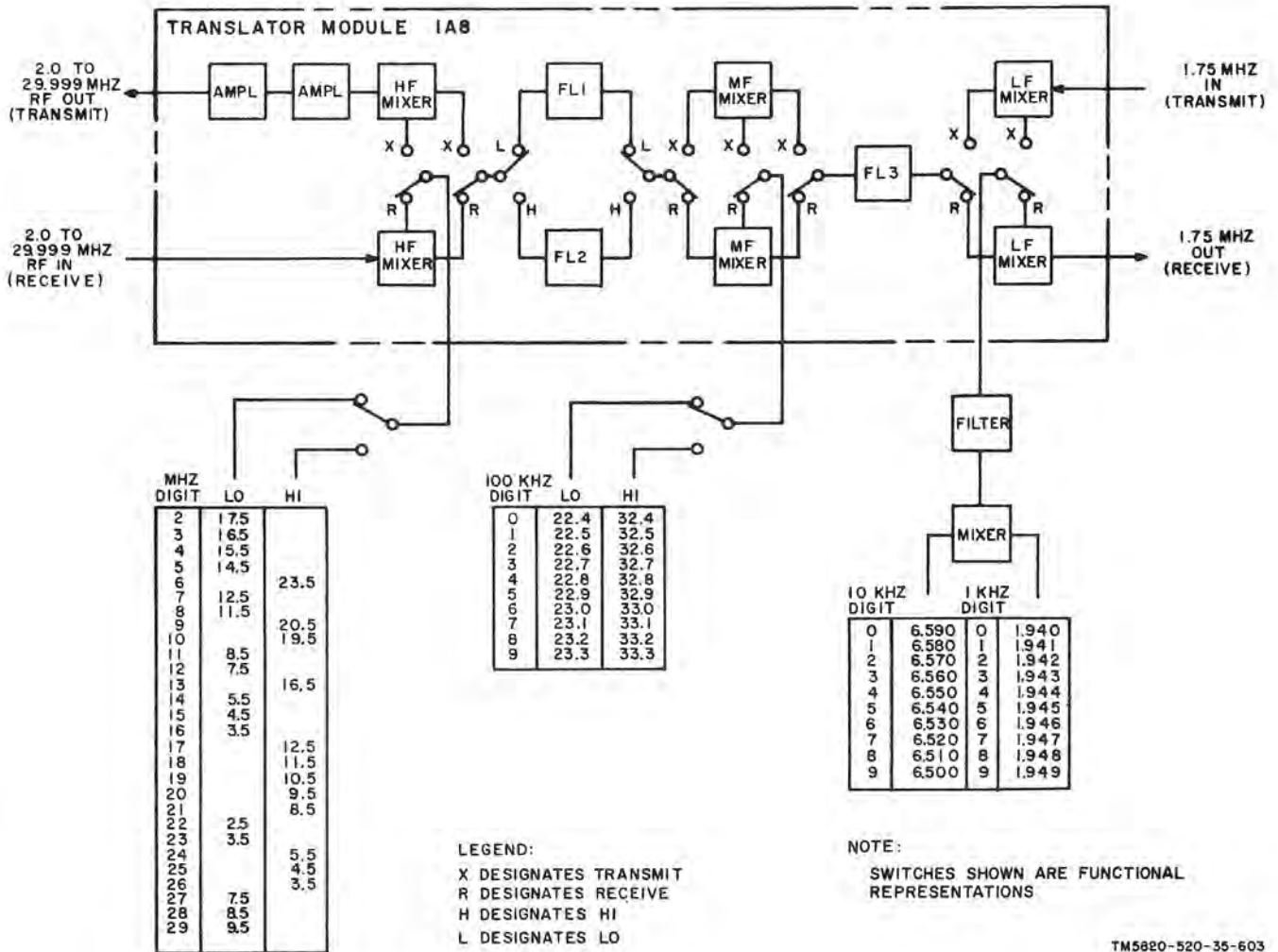

TM5820-520-35-603

Figure 1-3. Receiver-Transmitter, Radio RT-662/GRC, frequency scheme, block diagram.

applied to mixer A2Q4, where it is mixed with that spectrum point in the 100 kHz spectrum that will produce an output of 10.747 MHz from filter A2FL1. The difference product between the 15.3 MHz spectrum point and the assumed 4.5533 MHz oscillator output is a 10.7467 MHz output. This frequency is within the passband of filter A2FL1. Therefore, the 10.7467 MHz signal will be applied to mixer A3Q2, where it will be mixed with the 7.1 MHz signal from 10 and 1 kHz synthesizer module 1A4. The mixing products from the output of mixer A3Q2 are applied to filter A3Y2. Filter A3Y2 will allow only the additive product (17.8467 MHz) to pass. This frequency is applied to balanced mixer A1CR3, since the desired output lies in the lo band of output frequencies. The output from oscillator A4Q1 is also applied to balanced mixer A1CR3. The 17.8467 MHz and 4.5533 MHz signals are mixed in bal-

anced mixer A1CR3, from which the products are applied to amplifier A1Q2. The output for amplifier A1Q2 is a triple-tuned filter, which has a bandpass from 22.4 to 23.3 MHz. Therefore, the additive product (22.4 MHz) will be at the output from the module and will be at the exact frequency required. If a hi band frequency output were required, a similar cancellation would have taken place as follows. The 17.8467 MHz would have been applied to mixer A3Q1, where it would have been mixed with the 10 MHz input and applied to filter A3Y1. This would have resulted in a 27.8467 MHz output from filter A3Y1, which would be applied to balanced mixer A1CR4. The 4.5533 MHz output from oscillator A4Q1 is also applied to balanced mixer A1CR4. These two inputs are mixed and filtered in the hi band input to the triple-tuned filter, which has a passband from 32.4 to 33.3 MHz. There-

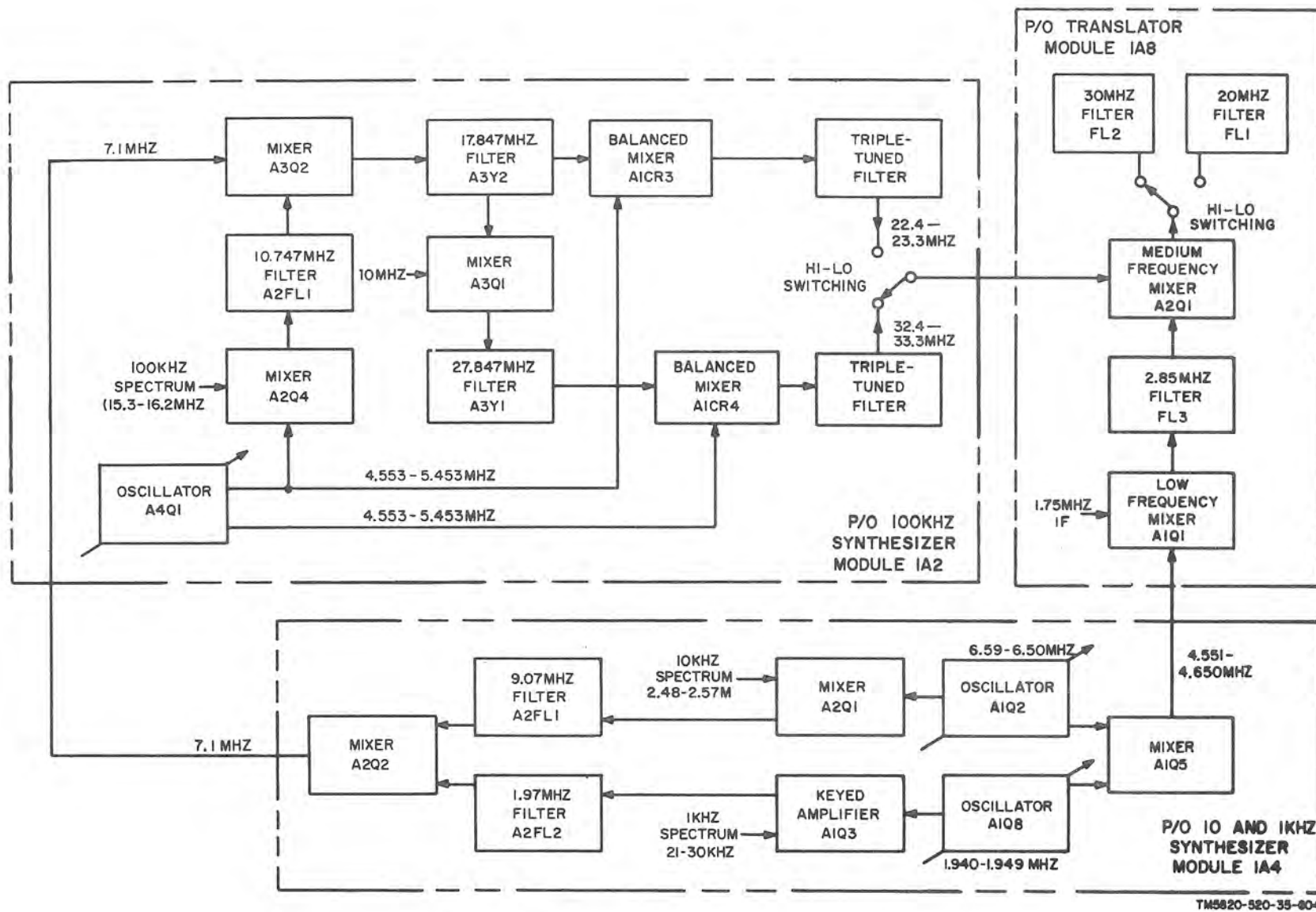

TM5820-520-35-804

Figure 1-4. Receiver-Transmitter, Radio RT-662/GRC, error cancellation, block diagram.

fore, the additive mixing product (27.8467 MHz plus 4.5533 MHz, 32.4 MHz) will be at the module output and will be the exact frequency required.

d. 10 and 1 kHz Synthesizer Module 1A4. The errors of the two crystal oscillators in 10 and 1 kHz synthesizer module 1A4 are also introduced into the output from 100 kHz synthesizer module 1A2. During the process of conversion in translator module 1A8, the errors will be completely eliminated. For simplicity of discussion, assume that crystal oscillator A4Q1 in 100 kHz synthesizer module 1A2 has no error. Also, assume that the output from oscillator A1Q2 in 10 and 1 kHz synthesizer module 1A4 should be 6.50 MHz, but is 300 hertz high, or 6.5003 MHz. Further, assume that the output from oscillator A1Q8 should be 1.949 MHz, but is 100 hertz high, or 1.9491 MHz. These two outputs will be applied to mixer A1Q5, producing a difference product output of 4.5512 MHz (200 hertz error). This output is injected into low-frequency mixer A1Q1 in translator module 1A8, where it is mixed with the 1.75 MHz IF input. The output from mixer 1A8A1Q1 is applied to filter 1A8FL3, which has a passband from 2.80 to 2.90 MHz. Therefore, the difference product (4.5512 MHz, 1.75 MHz, or 2.8012 MHz) will pass and be applied to medium-frequency mixer 1A8A2Q1. The output from oscillator 1A4A1A2 (6.5003 MHz) is also applied to mixer 1A4A2Q1, where it will mix with the 2.57 MHz spectrum point in the 10 kHz spectrum. The output from mixer 1A4A2Q1 is then applied to filter 1A4A2FL1, which will pass only the additive mixing product (9.0703 MHz). Similarly, the output from oscillator 1A4A1Q8 (1.9491 MHz) will be additively mixed with the 21st harmonic of the 1 kHz pulse, producing a 1.9701 MHz output from filter 1A4A1FL2. These two outputs are applied to mixer 1A4A2Q2, where they are subtractively mixed, resulting in a 7.1002 MHz output. This 7.1002 MHz output is applied to mixer 1A2A3Q2 in 100 kHz synthesizer module 1A2, where it is mixed with the 10.747 MHz output from filter 1A2A2FL1. Assuming that the output from 100 kHz synthesizer module 1A2 should be 22.4 MHz, the low band path will be energized. Therefore, the output from filter 1A2A3Y2 will be applied to balanced mixer 1A2A1CR3. This output (10.747 MHz plus 7.1002 MHz or 17.8472 MHz) is additively mixed with the 4.553 MHz output from oscillator 1A2A4Q1. Therefore, the output from the triple-tuned filter will be 22.4002 MHz (200 hertz high). The output from the triple-tuned fil-

ter is applied to medium-frequency mixer 1A8A2Q1 in translator module 1A8. Since a low band frequency output from 100 kHz synthesizer module 1A2 is used, the output from medium-frequency mixer will be applied to filter 1A8FL1, which has a passband from 19.5 to 20.5 MHz. The mixing product output from mixer 1A8A2Q1 that falls in this passband is the difference product. Since both inputs of mixer 1A8A2Q1 are 200 hertz high, and are subtractively mixed, the error will be canceled. Therefore, any crystal error will be canceled, resulting in an output from the receiver-transmitter exactly as indicated by the MHz and kHz controls on the front panel.

1-22. Frequency Synthesis for RT-834/GRC

a. General. The addition of 100 Hz tuning in the RT-834/GRC requires a change in the method used to obtain the necessary frequencies. A discussion of the theory of operation for the 10 and 1 kHz synthesizer module 1A4 is given in paragraph 1-23 and a discussion of the 100 Hz module 1A1A2A8 is presented in paragraph 1-24. Throughout this description reference is made to the block diagram of the frequency synthesis system for Receiver-Transmitter Unit RT-834/GRC (fig. 1-5). The frequency synthesis system involves the following modules:

- Frequency standard 1A3
- Frequency divider 1A6
- MHz synthesizer 1A9
- 100 kHz synthesizer 1A2
- 10 kHz and 1 kHz synthesizer 1A4
- 100 Hz synthesizer 1A1A2A8
- Translator 1A8
- IF amplifier 1A7
- 1750 kHz SSB crystal filter

The same frequency synthesis system is used for both the receive mode and the transmit mode, except that the synthesis for the transmit mode is followed in the reverse order from that for the receive mode. Basically, the function of the frequency synthesis system is to convert any frequency within the range of 2 to 29.999 MHz to a 1.75 MHz signal when the RT-834/GRC is in the receive mode. Conversely, in the transmit mode the function is to convert the 1.75 MHz intermediate frequency to any desired frequency within the range of 2 to 29.999 MHz. Frequency accuracy and frequency stability are achieved by the use of a stable, oven controlled, master oscillator in the Frequency Standard module. All of the injection frequencies are derived from the master oscillator. In addition, a frequency error cancelling system has been incorporated into the

synthesis system. Thus, the frequency control system has the same accuracy and stability as the master oscillator.

b. Receive Mode Functional Description. The frequency synthesis system of the RT-834/GRC is shown by a specific example below. All frequencies are synthesized by the same process, so the example serves to illustrate the general functions.

(1) Assume that the received signal is a continuous sine wave at a frequency of 7.276,000 MHz. The easiest way to detect this signal is to tune the receiver to a frequency slightly different than the received signal so that an audio beat frequency can be heard. For this example the frequency selector knobs on the front panel are tuned to 7.275,300 MHz so that a 700 Hz audio tone is heard. The receiver must always be tuned to a frequency lower than the received signal if a beat frequency is to be heard. This is due to the modulation system which is single sideband in all operational modes. This system employs the upper sideband only, thus beat frequencies that would normally be audible when the receiver is tuned to a frequency higher than the received signal are filtered out by the ssb crystal filter in the receiver IF module.

(2) The 7.260 MHz signal from the rf amplifier module 1A12, is applied to the high frequency mixer in the translator module 1A8, where it is mixed with the output of the MHz synthesizer module 1A9. (For an explanation of how the module output frequencies are derived, see the discussion for the individual modules.) The output of the MHz synthesizer for the 7 MHz digit is 12.5 CHz and low band operation. The output of the high frequency mixer in the translator module is then applied to the low band filter FL1 where the mixer product in the band from 19.5 to 20.5 MHz is selected. The mixing action is as follows:

Rf amplifier module 1A12 output	7.260 MHz
MHz synthesizer module 1A9 output	12.500 MHz
<hr/>	
Filter FL1 in translator module output	19.760 MHz

(3) The 19.76 MHz signal is then applied to the medium frequency mixer in the translator module. The other input to the medium frequency mixer is the output of the 100 kHz synthesizer module 1A2 which carries the 100 kHz and 100 Hz digit information. The output frequency of the 100 kHz synthesizer is 22.6 MHz due to the 100 kHz digit of 2 and low band operation, plus the 300 Hz information to the 100 Hz digit of 3

which is 22.6003 MHz at the output of the 100 kHz synthesizer module. This 22.6003 MHz signal is the other input to the medium frequency mixer and is mixed with the output of filter FL1. The mixer products are then applied to filter FL3 where the product in the range of 2.8 to 2.9 MHz is selected. With the frequencies of the example, the following mixing takes place:

100 kHz synthesizer module 1A2 output	22.6003 MHz
Filter FL1 output	19.7760 MHz
<hr/>	
Filter FL3 output	2.8243 MHz

(4) The 2.8243 MHz signal from filter FL3 is then applied to the low frequency mixer where it is mixed with the output of the 10 and 1 kHz synthesizer module 1A4. The output frequency of the 10 and 1 kHz synthesizer module is 4.575 MHz when the 10 kHz digit is 7 and the 1 kHz digit is 5. The mixer products from the low frequency mixer then go to the SSB crystal filter where the product in the range of 1750.4 to 1753.4 kHz is selected. For example, the following mixing is accomplished:

10 and 1 kHz synthesizer module 1A4 output	4.5750 MHz
Filter FL3	2.8243 MHz
<hr/>	
SSB crystal filter output	1.7507 MHz

Thus, the frequency synthesis is essentially complete since the original 7.276 MHz input signal has been converted to the desired 1.75 MHz signal. However, one more step in the example will show how the 700 Hz audio frequency is produced.

(5) The 1.7507 MHz signal from the SSB crystal filter flows into the IF amplifier module 1A7 where, in all receive modes except cw, it is mixed with the 1.75 MHz output from the frequency divider module 1A6. An audio frequency filter in the IF amplifier module allows the mixer product in the audio frequency range to pass out of the module. The mixing takes place as follows:

SSB crystal filter output	1.7507 MHz
Frequency divider module 1A6 output	1.7500 MHz
<hr/>	
Audio frequency out of IF amplifier module	0.0007 MHz

Thus, tuning the receiver 700 Hz lower than the incoming signal produces a 700 Hz audio frequency.

(6) In the cw mode, the 1.75 MHz signal from the frequency divider is not used. Instead, a variable frequency oscillator in the receiver IF module 1A7, that can be varied plus or minus a few thousand Hz about 1.75 MHz, is used as the

mixer input. The audio frequency can then be varied depending on the frequency of this bfo oscillator.

(7) The use of the frequency standard module 1A3 and the frequency divider module 1A6 outputs are obvious. These two modules have been included in the block diagram so that a more complete representation of the synthesis system can be seen. The frequencies used as examples in the individual module descriptions are the same frequencies used in the example of the complete synthesis scheme.

c. *Error Cancellation.* As an example of the frequency error cancellation system, assume that the input from the 1A4 module is 4.575396 MHz for the 10 and 1 kHz output and 7.089396 MHz for the 7.089 MHz output. The method by which these frequencies are generated is explained below in the 10 and 1 kHz synthesizer module discussion (3). The 7.089 MHz output from the 10 and 1 kHz synthesizer module is applied to the 100 Hz synthesizer module where the 100 Hz information is added to the 7.089,396 MHz carrier. The mixing process is accomplished as follows:

7.089 MHz output from 10 and 1 KHz synthesizer module	7.089,396 MHz
100 Hz information from 100 Hz synthesizer	.011,300 MHz
<hr/>	
100 Hz synthesizer module output	7.100,696 MHz

(1) This output from the 100 Hz synthesizer module is applied to the 100 kHz synthesizer module 1A2 where the difference between 7.100,000 MHz and the 7.1 MHz input signal is added to the output of the 100 kHz synthesizer. The output frequency at the 100 kHz synthesizer is then:

100 Hz synthesizer module output reference	7.100,696 MHz
	7.100,000 MHz
<hr/>	
added to the 100 kHz information	0.000,696 MHz
100 kHz information in 100 kHz synthesizer	22.600,000 MHz
<hr/>	
100 kHz synthesizer module output	22.600,696 MHz

(2) The 100 kHz synthesizer output is then applied to the medium frequency mixer in the translator module 1A8 where it is mixed with the output of filter FL1 as follows:

100 kHz synthesizer module output	22.600,696 MHz
Filter FL1 output	19.776,000 MHz
<hr/>	
Filter FL3 output	2.824,696 MHz

(3) The output of filter FL3 is then applied to the low frequency mixer where it is mixed with the 10 and 1 kHz output from the 10 and 1kHz synthesizer module as follows:

10 and 1 kHz synthesizer module output	4.575,396 MHz
Filter FL3 output	2.824,696 MHz
<hr/>	
SSB crystal filter output	1.750,700 MHz

(4) This is exactly the same frequency that was obtained at this point in the example that assumed no frequency error. Hence, by subtractively mixing the error in two mixers, the frequency error due to the 10 and 1 kHz synthesizer module has been eliminated.

d. *Transmit Mode Functional Description.* The transmit mode functions in reverse order of the receive mode. However, the frequency vernier is not operational in the transmit mode and the transmitted signal in the cw mode is 2 kHz higher than the dialed frequency due to the 2 kHz sidetone. The 1 kHz pulse from the frequency divider module 1A6 goes to the transmit IF and audio module 1A5 when the cw transmit mode where the frequency is doubled to produce the 2 kHz sidetone which follows the same signal path as the audio input signal to the transmit IF and audio module. The 2 kHz sidetone is also routed into the audio system of the RT-834/GRC to produce an audio frequency used to monitor cw keying.

(1) The RT-834/GRC uses single sideband modulation employing the upper sideband only, no output signal is present at the output of the RT-834/GRC unless an audio modulation signal is applied to the input. This is due to the narrow passband of the ssb crystal filter. The lower limit of the passband is 1750.4 kHz, so the 1750 kHz signal that would represent the am carrier in normal am modulation is filtered out by the ssb crystal filter. This is true for all transmit modes except the am mode. The 2 kHz tone is also the effective audio input in the cw mode. In the am mode the 1750 kHz carrier is reinserted after the ssb crystal filter. This process does not produce true amplitude modulation, because the am signal consists of the upper sideband and a reduced level carrier. The lower sideband is missing, having been removed by the ssb crystal filter. However, this modified am signal can still be detected using conventional am methods.

(2) In all modes except the am mode, there is no carrier present at the RT-834/GRC output. If a single audio tone is used as a modulating signal, the rf output of the RT-834/GRC will be the frequency selected by the front panel knobs plus the frequency of the modulating tone.

(3) As an example of transmit operation, assume that the RT-834/GRC is tuned to the same frequency that was used in the receive mode

example and that the 700 Hz audio tone that was the output in the receive example is used as a modulation input. Then the output frequency of the RT-834/GRC should be the dial frequency, 7.2753 MHz, plus the modulation frequency, 700 Hz, or 7.1760 MHz.

(4) The output frequencies of the individual synthesizer modules are then the same as those shown in the receive mode example and the action of the frequency error cancelling loop is the same. The synthesis system starts with the 700 Hz audio signal being applied to the transmit IF and Audio module 1A5 where it is mixed with the 1.75 MHz carrier reinsertion signal from the frequency divider module 1A6. The mixer products then go to the ssb crystal filter where the product in the range of 1750.4 to 1753.4 to 1753.4 kHz is selected as follows:

Carrier reinsertion from frequency divider	1.750,000 MHz
Audio input	0.000,700 MHz
<hr/>	
SSB crystal filter output	1.750,700 MHz

(5) This 1.75 MHz signal is then applied to the low frequency mixer in the translator module 1A8 where it is mixed with the 10 and 1 kHz output from the 10 and 1 kHz synthesizer module 1A4. The mixer products are then applied to filter FL3 where the product in the range of 2.8 to 2.9 MHz is selected as follows:

10 and 1 KHz synthesizer module 1A4 output	4.575,000 MHz
SSB crystal filter output	1.750,700 MHz
<hr/>	
Filter FL3 output	2.824,300 MHz

(6) This output from filter FL3 is then applied to the medium frequency mixer in the translator module where it is mixed with the output of the 100 kHz synthesizer module 1A2. The mixer products are applied to filter FL1 where the product in the range of 19.5 to 20.5 MHz is selected as follows:

100 kHz synthesizer module 1A2 output	22.600,300 MHz
Filter FL3 output	2.824,300 MHz
<hr/>	
Filter FL1 output	19.776,000 MHz

(7) The output of filter FL1 is then applied to the high frequency mixer in the translator module where it is mixed with the output of the MHz synthesizer module 1A9. The mixer products are then sent to the rf amplifier module 1A12 where the 7 MHz product is selected as follows:

Filter FL1 output	19.776,000 MHz
MHz synthesizer module 1A9 output	12.500,000 MHz
<hr/>	
Rf amplifier module 1A12 output	7.276,000 MHz

(8) This is the desired frequency, thus the frequency synthesis process is complete. The output frequency, 7.2760 MHz is 700 Hz higher than the dial frequency as was stated in the beginning of the example.

1-23. 10 and 1 kHz Synthesizer Module 1A4 Functional Description

a. *Inputs.* The inputs are as follows:

(1) 10 kHz Spectrum (J1A-A1)—2.48 to 2.57 MHz spectrum in 10 kHz increments with an amplitude of 2.6 +1.2 MV (heterodyne voltmeter).

(2) 1 kHz Spectrum (J1A-A2)—1 kHz pulses with a pulse repetition rate of 1 millisecond and an amplitude of 1.5 +0.5 volts peak-to-peak (oscilloscope).

b. *Outputs.* The outputs are as follows:

(1) 10 and 1 kHz Synthesizer (J1B-A3)—4.55 to 4.650 MHz sine wave at an amplitude of 120 +30 MV rms (RF Voltmeter).

(2) 7.089 MHz (J1A-A1)—7.089 MHz +400 Hz sine wave at an amplitude of 35 +5 MV rms (RF Voltmeter).

c. *Functional Description.* Refer to the detailed block diagram (fig. 1-6) for the 10 and 1 kHz synthesizer module 1A4. The module consists of two oscillators and a series of mixers. The 10 and 1 kHz output of the module provides information for controlling both the 10 kHz and 1 kHz frequency selection. The 7.089 MHz output serves as a carrier for 100 Hz information which is impressed on it in the 100 Hz synthesizer module 1A1A2A8, and as a carrier for frequency error in the module. That is, the 7.089 MHz output contains exactly the same frequency error as the 10 and 1 KHz output. Since no internal frequency error correction is provided within the module, the frequency error on the 7.089 MHz output is used to correct the 10 and 1 kHz output frequency error in a circuit external to this module. This frequency error correction system can be seen only from a study of the total synthesis system of the RT-834/GRC.

(1) Two examples will serve to illustrate the internal functions of the module. The first example assumes that the oscillators have no frequency error and will show the basic internal module functions. The second example, an error will be introduced in the oscillator frequencies to

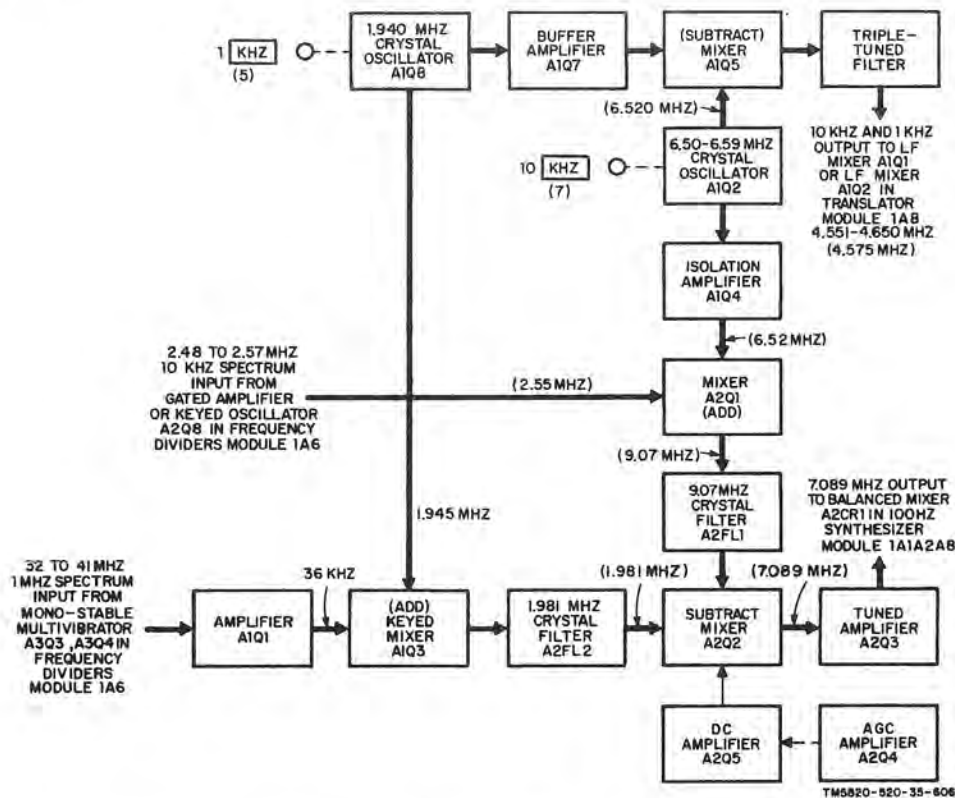

Figure 1-6. Receiver-Transmitter, Radio RT-834/GRC, 10 and 1 kHz synthesizer 1A4, detailed block diagram.

show that both module outputs contain the same frequency error.

(2) For the first example, assume that the 10 kHz and the 1 kHz frequency selector knobs on the front panel of the RT-834/GRC are in the 7 and the 5 positions respectively. Also, assume that crystal oscillators A1Q2 and A1Q8 have no frequency error. Then, referring to the block diagram, the 10 kHz crystal oscillator A1Q2 is oscillating at 6.520 MHz. One output from this oscillator goes to mixer A1Q5 where it is mixed with one output of the 1 kHz crystal oscillator A1Q8, 1.945 MHz, which flows through buffer amplifier A1Q7 into mixer A1Q5. The mixer products from mixer A1Q5 then flow into the triple tuned filter where the mixer product, that is the difference between the two mixing frequencies, is selected. In the example, the mixing is accomplished as follows:

10 kHz crystal oscillator A1Q2 output	6.520 MHz
1 kHz output from buffer amplifier A1Q7	1.945 MHz
<hr/>	
Mixer product selected by triple tuned filter	4.575 MHz

The 4.575 MHz output from the triple tuned filter serves as the 10 and 1 kHz synthesizer mod-

ule output and goes to the low frequency mixer in the translator module 1A8.

(3) The other output from the 10 kHz crystal oscillator A1Q2 flows through isolation amplifier A1Q4 into mixer A2Q1 where it is mixed with the 10 kHz spectrum input from the frequency divider module 1A6. The mixer products from mixer A2Q1 flow into crystal filter A2FL1 where the product closest to 9.07 MHz is selected. Observe that regardless of which crystal frequency is selected in the 10 kHz crystal oscillator, there is a particular 10 kHz spectrum point that can be mixed with the oscillator frequency to produce a signal near 9.07 MHz. This is also the case for the 1 kHz crystal oscillator and the 1 kHz spectrum input for producing 1.981 MHz. The 10 kHz oscillator frequency and the 10 kHz spectrum are mixed as follows:

10 kHz output from isolation amplifier A1Q4	6.520 MHz
10 kHz spectrum point at	1.550 MHz
<hr/>	
Output of crystal filter A2FL1	9.070 MHz

The output of crystal filter A2FL1 goes to mixer A2Q2. The other input to mixer A2Q2 is derived from the 1 KHz crystal oscillator.

(4) The other output from 1 kHz crystal oscillator A1Q8 flows to keyed mixer A1Q3 where it is mixed with the 1 kHz spectrum input from the frequency divider module 1A6 through amplifier A1Q1. The mixer action is the same as described for the 9.07 MHz crystal filter output. The mixer products from keyed mixer A1Q3 flow into crystal filter A2FL2 where the product nearest 1.981 MHz is selected. In the example, the following mixing takes place:

1 kHz crystal oscillator A1Q8 output	1.945 MHz
1 kHz spectrum point from amplifier A1Q1	.036 MHz
<hr/>	
Output of crystal filter A2FL2	1.981 MHz

(5) The 1.981 MHz output from crystal filter A2FL2 is the second input to mixer A2Q5, along with the 9.07 MHz output from crystal filter A2FL1. The mixer products from mixer A2Q5 flow into tuned amplifier A2Q3 where the product nearest 7.089 MHz is selected and amplified. In this example the mixing takes place as follows:

Crystal filter A2FL1 output	9.070 MHz
Crystal filter A2FL2 output	1.981 MHz
<hr/>	
Tuned amplifier A2Q3 output	7.089 MHz

The 7.089 MHz output from tuned amplifier A2Q3 serves as the 7.089 MHz module output and goes to the balanced mixer in the 100 Hz Synthesizer module 1A1A2A8.

(6) A sample of the 7.089 MHz output signal from tuned amplifier A2Q3 is fed to agc amplifier A2Q4 where it is amplified and detected. The dc output is applied to dc amplifier A2Q5 where it is amplified and used to control the output level of mixer A2Q2. Since the output of dc amplifier A2Q5 is proportional to the output level of the 7.089 MHz signal, the output level of mixer A2Q5 changes in such a way as to maintain the 7.089 MHz module output at a constant level.

(7) For the next example, assume the same conditions as was used in the first example except that the 10 kHz crystal oscillator has a frequency error or 186 Hz high and the 1 kHz crystal oscillator has a frequency error of 210 Hz low. The crystal oscillator frequencies are then 6.520,186 MHz for the 10 kHz crystal oscillator A2Q2 and 1.944,790 MHz for the 1 kHz crystal oscillator A1Q8. A numerical study of the mixing system will show that both the 10 and 1 kHz module output and the 7.089 MHz module output have exactly the same frequency error.

(8) Following the same signal flow as described in the first example, the first mixer encountered is mixer A1Q5 which subtractively mixes the two crystal oscillator frequencies to produce the 10 and 1 kHz module output frequency as follows:

10 kHz crystal oscillator A1Q2 output	6.520,186 MHz
1 kHz output from buffer amplifier A1Q7	1.944,790 MHz
<hr/>	
Mixer product selected by triple tuned filter (also output frequency of the 10 and 1 kHz output (from the module.)	4.575,396 MHz

Notice that this frequency differs by 396 Hz from the 10 and 1 kHz module output frequency in the first example. The same 396 Hz difference should be seen at the 7.089 MHz output from the module.

(9) The next mixer encountered in the signal flow is mixer A2Q1 which adds the 10 kHz oscillator frequency to the 10 kHz spectrum point to produce an output near 9.07 MHz, as follows:

10 kHz output from isolation amplifier A1Q4	6.520,186 MHz
10 kHz spectrum point at	2.550,000 MHz
<hr/>	
Output of crystal filter A2FL1	9.070,186 MHz

The next mixer in the signal flow is keyed mixer A1Q3 where the 1 kHz crystal oscillator frequency is added to the 1 kHz spectrum point to produce an output near 1.981 MHz as follows:

1 kHz crystal oscillator A1Q8 output	1.944,790 MHz
1 kHz spectrum point from amplifier A1Q1	.036,000 MHz
<hr/>	
Output of crystal filter A2FL2	1.980,790 MHz

(10) The last mixer encountered is mixer A2Q2 which subtractively mixes the 9.07 MHz output of crystal filter A2FL1 with the 1.981 MHz output of crystal filter A2FL2 to produce the 7.089 MHz output from the module as follows:

Crystal filter A2FL1 output	9.070,186 MHz
Crystal filter A2FL2 output	1.980,790 MHz
<hr/>	
Tuned amplifier A2Q3 output and also the 7.089 MHz module output.	7.089,396 MHz

(11) This output is 396 Hz higher than the 7.089 MHz output in the first example. Thus, the 396 MHz error due to the crystal oscillators is the same in both the 7.089 MHz module output and the 10 and 1 kHz module output.

d. Module Test Points. The following measurements (table 1-1) can be made with the mod-

ule mounted in the RT-834/GRC chassis. The output frequencies of the 10 and 1 kHz module are listed in table 1-2. Frequency measurements are made with a frequency counter and output level measurements are made with a high impedance rf voltmeter.

Table 1-1. 10 and 1 kHz Module Test Points

Test Point	Measurements
7.089 MHz OUT	7.089 MHz \pm 400 Hz sine wave with an amplitude of 35 \pm 5 MV RMS for all positions of the 10 kHz and the 1 kHz frequency selector knobs.
10 and 1 kHz SYNTH OUT	4.551 to 4.650 MHz sine wave with the same frequency error as the 7.089 MHz output at a level of 90 to 150 MV RMS. See table 1-2 for output frequency without error at various 10 kHz and 1 kHz frequency selector knob positions.

Table 1-2. 10 and 1 kHz Module Output Frequencies

10 kHz knob	1 kHz knob	Freq. without error—kHz
0	0	4650
1	0	4640
2	0	4630
3	0	4620
4	0	4610
5	0	4600
6	0	4590
7	0	4580
8	0	4570
9	0	4560
9	1	4559
9	2	4558
9	3	4557
9	4	4556
9	5	4555
9	6	4554
9	7	4553
9	8	4552
9	9	4551

1-24. 100 Hz Synthesizer Module 1A1A2A8

(fig. 4-47)

a. *Inputs.* The inputs are as follows:

(1) 7.089 MHz (A2-J1): 7.089 MHz \pm 400 Hz sine wave with an amplitude of 35 \pm 5 MV RMS (rf voltmeter).

(2) 1 kHz pulse (A1-J1): 1 kHz pulse with a pulse repetition rate of 1 millisecond, a

pulse width of 5 \pm 2 microseconds at 50% amplitude, and an amplitude of 1.5 \pm 0.5 volts peak-to-peak (oscilloscope).

b. *Outputs.* The outputs are as follows:

(1) 7.1 MHz (A2-J2): With an input of 7.089,000 MHz the 7.1 MHz output is a sine wave from 7.100,100 to 7.100,900 MHz in 100 Hz steps with an amplitude of 35 \pm 10 MV RMS (rf voltmeter). The frequency error in the 7.1 MHz output is the same as the frequency error of the 7.089 MHz input.

(2) 1 kHz pulse (A1-J2): the same as the 1 kHz pulse input at A1-J1.

c. *Functional Description.* Refer to the block diagram (fig. 1-7) for the 100 Hz synthesizer module 1A1A2A8. The module consists of a phase locked, voltage controlled oscillator, and a mixer. The voltage controlled oscillator is used to produce the 100 Hz information which is then impressed on the 7.089 MHz carrier in the mixer stage. The 7.089 MHz carrier also relays frequency error correcting information from the 10 and 1 kHz synthesizer module 1A4. This frequency error information along with the 100 Hz information is present at the output of the module. The internal functions of the module can best be shown by choosing a specific example.

(1) For example, assume that the 100 Hz frequency selector knob on the front panel of the RT-834/GRC is in the 3 position. Also assume that the 7.089 MHz input frequency is 7.089,000 MHz. Then, the voltage controlled oscillator, vco, is oscillating near 113 kHz. The 113 kHz output then goes to pulse shaper A2Q5 and A2Q6 where the level is adjusted so that the signal is compatible with the requirements of the integrated circuits. One output of the pulse shaper goes to preset divider A1Z1 through A1Z8. This preset divider is programable and is set to divide by any number from 110 to 119 depending on the position of the front panel switch. For this example the preset divider is programed to divide by 113, thus the 113 kHz input is divided to produce a 1 kHz signal which goes to one input of phase detector A1Z4. The other input to the phase detector comes from the 1 kHz pulse input from the frequency divider module 1A6 through pulse shaper A1Q1. The phase detector compares the frequency and phase of the 1 kHz signal from the preset divider to the frequency and phase of the 1 kHz signal from the frequency divider module 1A6. The output of the phase detector is pro-

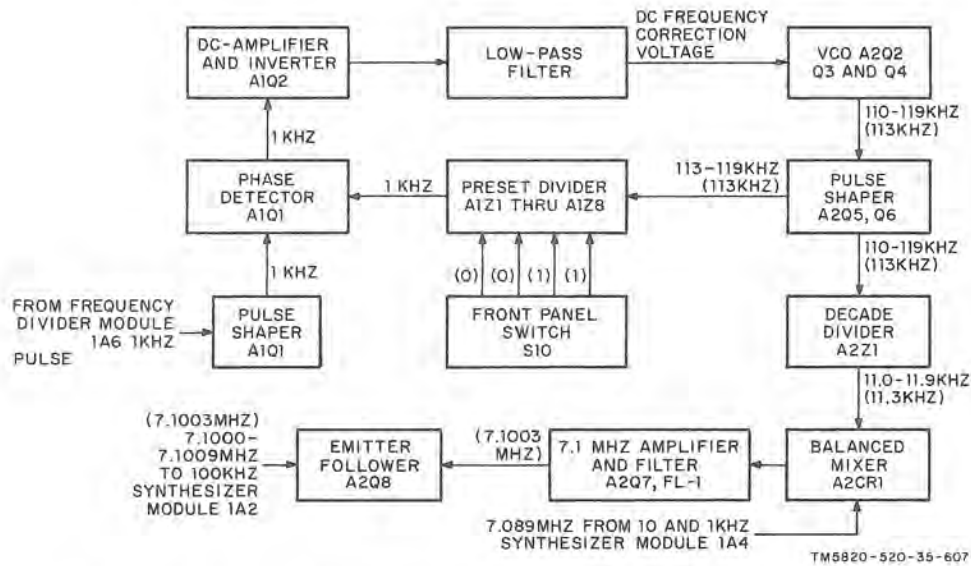

Figure 1-7. Receiver-Transmitter, Radio RT-834/GRC, error cancellation, block diagram.

portional to the frequency and phase difference of the two 1 kHz signals. The output of the phase detector goes to dc amplifier and inverter A1Q2 where the signal is amplified and inverted in polarity. From here, the signal flows through the low-pass filter where the ac component of the signal is removed. The dc output of the filter is used as a frequency error correction voltage to insure that the voltage controlled oscillator is running at exactly 113 kHz. Thus, the output frequency of the vco has the same frequency accuracy as the 1 kHz pulse input from the frequency divider Module 1A6.

(2) The other output of pulse shaper A2Q5 and A2Q6 goes to a decade divider that divides the 113 kHz signal by 10 to produce a 11.3 kHz signal. The 11.3 kHz signal is one input to balanced mixer A2CR1. The 7.089 MHz input from the 10 and 1 kHz synthesizer module 1A4 is the other input to balanced mixer A2CR1 where it is mixed with the 11.3 kHz signal. The mixer products then go to the 7.1 MHz amplifier and filter A2Q7 and FL1 where the mixer product nearest 7.1 MHz is selected and amplified. In the example, the following mixing takes place:

10 and 1 kHz synthesizer module input	7.089,000 MHz
Decade divider A2Z1 output	.011,300 MHz
<hr/>	
Amplifier and filter A2Q7 and FL1 output	7.100,300 MHz

(3) The 7.100,300 MHz signal then flows to emitter follower A2Q8 which serves as an im-

pedance matching stage for the module output. The 7.1003 MHz signal out of the emitter follower is the 7.1 MHz module output and goes to the 100 kHz synthesizer module 1A2.

(4) Since there is only one mixer in the module and the mixing action is additive, it can be shown that any frequency error on the 7.089 MHz input will appear at the 7.1 MHz output of the module. For example, if the 7.089 MHz input had a frequency error of 128 Hz, the 7.089 MHz input frequency would be 7.089,128 MHz. With the same 11.3 signal used in the previous example, the module output frequency would be:

7.089 MHz input from 10 and 1 kHz synthesizer	7.089,128 MHz
Decade divider A2Z1 output	.011,300 MHz
<hr/>	
100 Hz synthesizer module output	7.100,428 MHz

When the 300 Hz that is used for the 100 Hz tuning information is subtracted from the output frequency, the original 128 Hz frequency error is seen. This is the method used to carry the frequency error information from the 10 and 1 kHz synthesizer module to the 100 kHz synthesizer module. Thus, the 7.1 MHz module output carries the 100 Hz information and the 10 and 1 kHz synthesizer module frequency error information.

(5) The 1 kHz pulse output from the module is exactly the same as the 1 kHz pulse input to the module since the 100 Hz synthesizer module only samples the 1 kHz pulse signal.

**Section VI. POWER AND OPERATIONAL CONTROL, FUNCTIONAL
CIRCUIT ANALYSIS, RECEIVER-TRANSMITTER RADIO, RT-662/GRC
AND RT-834/GRC**

**1-25. Dc-to-Dc Converter and Regulator
Module 1A11**

(fig. 4-45)

a. General. Dc-to-Dc converter and regulator module 1A11 provides all operating voltages required by the receiver-transmitter, except the 27 ± 3 volts dc. A 20-volt regulator circuit and a dc-to-dc converter circuit are used to produce the required voltages from the 27 volts dc primary power.

NOTE

Prefix all reference designators in this paragraph with Dc-to-Dc converter and regulator module reference designator 1A11, unless otherwise specified.

b. 20-Volt Regulator. The 20-volt regulator circuit provides a 20-volt regulated output to all modules of the receiver-transmitter for any operate position (SSB NSK, AM, CW, and FSK) of the SERVICE SELECTOR switch.

(1) The 27 volts dc is applied to the collector of transistor 1A1Q1 on the chassis. The effective collector-to-emitter resistance of transistor 1A1Q1, in series with the 27 volts dc line, drops the voltage to a constant 20 volts dc for any given current required by the external circuit. The value of the series resistance is determined by the rate of conduction of transistor 1A1Q1, which is controlled by the regulator circuit.

(2) Differential amplifier A1Q3, A1Q4 compares the output from transistor A1Q1 with the reference established by 4.7 volt Zener diode A1VR2. The output at the emitter of transistor 1A1Q1 is developed across the voltage divider consisting of resistors A1R7, A1R8, and A1R9. Assume that the 20 volt dc output instantaneously increases the 22 volts dc. The voltage across the voltage divider will increase, increasing the forward bias on transistor A1Q4. Transistor A1Q4 will have an increased rate of conduction, increasing the voltage developed across resistor A1R6. This decreases the forward-biasing of transistor A1Q3. This increased voltage will decrease the forward bias on dc amplifier A1Q2, increasing the voltage on the collector of dc amplifier A1Q2. The base voltage of dc amplifier A1Q2 is stabilized by Zener diode A1VR1. Therefore, the emitter-to-base voltage on driver A1Q1 will decrease, decreasing the voltage on the col-

lector of driver A1Q1. The collector voltage of driver A1Q1 is the base bias for transistor 1A1Q1. Therefore, the decrease at the collector of driver A1Q1 causes transistor 1A1Q1 to conduct less. This increases the collector-to-emitter resistance to drop the voltage back to 20 volts dc. A similar sequence will occur if the 20 volts dc decreases. However, the reverse will occur in all the circuits in order to increase the conduction rate of transistor 1A1Q1, thereby decreasing the collector-to-emitter resistance to increase the voltage at the emitter of transistor 1A1Q1 to 20 volts dc.

(3) Capacitor A1C5 provides filtering for the 20-volt dc output line. Capacitor A1C4 provides collector-to-base feedback for transistor A1Q4. Therefore, any ripple on the 20-volt dc output line will be fed back into the regulator circuit, and in turn to transistor 1A1Q1, 180° out of phase with itself. This allows the ripple to be canceled. Capacitors A1C1, A1C2, and A1C3 provide high-frequency filtering. If the 20 volt dc line becomes shorted, the resulting ground will forward-bias diode A1CR1. This will shut off dc amplifier A1Q2, which in turn shuts off driver A1Q1 and transistor 1A1Q1. When the short is removed, the regulator will recover and resume regulating action.

c. Dc-to-Dc Converter. The dc-to-dc converter is a saturable core oscillator used to produce the dc and ac operating voltages required by amplifier tubes 1A12V1 and 1A12V2. This circuit is in operation during STAND BY or any operating position (SSB NSK, AM, CW, or FSK) of the SERVICE SELECTOR switch.

(1) The 27 volts dc primary power is applied to pin 7 of connector J1, from which it is applied through a pi-section filter network to pin 9 of transformer T1. The pi-section filter consists of inductor L1 and capacitors A2C1, A2C2, A2C3, and A2C4. The 27 volts dc is applied through the transformer winding to the collector of both transistors Q1 and Q2 and through resistor A2R1, the transformer winding, and resistors R1 and R2 to the bases of transistors Q1 and Q2. The differences in the two transistors will cause one of them to turn on first. Assume that transistor Q1 turns on first. Then application of 27 volts dc will induce a voltage in the windings of transformer T1 with the following polarities: pin 9, plus; pin 2, minus; pin 1; and pin 3, minus. Therefore, transistor Q1 is more forward-biased

by the positive voltage on its base, driving it toward saturation. Transistor Q1 will conduct into saturation, at which time the magnetic field created in the windings will collapse since the current becomes constant. Therefore, the polarities of the windings will be reversed, turning transistor Q2 on. This action will continue, producing a square wave ac signal across the primary of transformer T1. Resistors R1 and R2 are base current-limiting resistors. Diode A2CR1 will clamp pin 10 of transformer T1 at ground so that maximum drive can be applied to the conducting transistor to drive it into saturation.

(2) The 54 volts ac output from de-to-dc converter switch Q1, Q2 is stepped down in transformer winding 4-5, filtered, and applied to pins 1 and 9 of connector J1. This stepped-down voltage is the 6.3 volts ac required for the filaments of amplifier tubes 1A12V1 and 1A12V2. The 54 volts ac is stepped up by transformer winding 6-12, full-wave rectified by diodes A3CR1 through A3CR4, filtered, and applied to pin 6 of connector J1. This voltage is the positive 125 volt dc output for the plates and screens of amplifier tubes 1A12V1 and 1A12V2. The 54 volts ac is stepped up by transformer winding 7-8, full-wave rectified by diodes A3CR5 through A3CR8, regulated by 33 volt Zener diode A3VR1 when SERVICE SELECTOR switch is at STAND BY filtered and applied to pin 14 of connector J1. This voltage will be nominally 130 volts dc but will vary ± 10 percent with like variations in the 27 volt dc primary power input. This voltage is the -30 volts dc used to develop the agc voltage used in rf amplifier module 1A12 during receive operation. During standby, this voltage will result in the full-scale deflection of the front panel signal level meter to allow the operator a means of insuring the dc-to-dc converter module 1A11 is functioning. When the receiver-transmitter is tuning, this -33 volts dc is used to bias the rf amplifier tubes to cutoff to prevent over-dissipation in their screen circuits.

1-26. Front Panel and Chassis Assembly 1A1

(fig. 4-33)

a. *General.* Front panel and chassis assembly 1A1 contains all the interconnections for the modules, the code switches for intraunit tuning (receiver-transmitter, and interunit tuning) (Amplifier, Radio Frequency AM-3349/GRC-106), Internal alC assembly 1A1A5, 100 Hz module 1A1A2A8 and all switches and controls for de-

termining and controlling the various modes of operation in either a transmit or receive condition.

NOTE

Prefix all reference designators in this paragraph with front panel and chassis assembly reference designator 1A1, unless otherwise specified.

b. *SERVICE SELECTOR Switch.* SERVICE SELECTOR switch S4 is used to select the mode of operation for Radio Set AN/GRC-106(*).

(1) The 27 volts dc applied to pins A and B POWER connector J24 is applied through FUSE 2 AMP F1, diode CR1, and filter FL1 to contact 2 of switch S4 section 1, front. Diode CR1 is used to insure correct polarity of the 27 volts dc applied to POWER connector J24. Zener diode VR2 will fire when the voltage approaches 30 volts dc, increasing the current through fuse F1 to insure that it opens. Filter FL1 is a low-pass radio frequency interference (rfi) feedthrough filter, designed to suppress unwanted rfi that may be present on the 27 volt dc input line. When the SERVICE SELECTOR switch is set at OVEN-ON, the 27 volts dc is applied through contacts 1 and 2 of switch S4, section 1, front, to pin 3 of connector XA3-A. This voltage is then used in frequency standard module 1A3 to energize the oven assembly (para 1-15). When the SERVICE SELECTOR switch is set at STAND BY, the 27 volts dc is applied through contacts 2 and 3 of switch S4, section 1 front, and to pin 7 of connector XA11, pin 28 to connector XA5, and to the OVEN-ON circuits (XA3A-3). This voltage is used in Dc-to-Dc converter and regulator module 1A11 to energize the dc-to-dc converter circuit (para 1-25). This voltage is used in transmitter IF and audio module 1A5 to energize the vox circuit (para 1-6) so that when the receiver-transmitter is placed in operation, surges from the 20 volts dc application will not place the system into transmit condition. When the SERVICE SELECTOR switch is placed at any operate position (SSB NSK, FSK, AM, CW), the 27 volts dc is applied to all STAND BY and OVEN-ON circuits as previously explained and through contacts 1 and 4 of switch S4, section 1, front, to the following places:

(a) Pin K of AUDIO connectors J18 and J19 for auxiliary used.

(b) Pin 8 of connector XA10 to energize the 2 watt amplifier portion of receiver audio module 1A10 (para 1-13).

(c) Pin 3 of relay K2 and pin E3 of assembly A7.

(d) Contact 6 of relay K2, from which it is applied through contact 8 (when motor B1 is unenergized) to pin 2 of relays K3 and K4, pin 4 of relay K1, the collector of transistor Q1 (para 1-25), and pin 13 of connector XA11 to energize the 20-volt regulator circuit of Dc-to-Dc Converter and regulator module 1A11 (para 1-25).

(e) Contact 5 of relay K2, from which motor B1 is energized through contact 2 of relay K2 (*d* below).

(2) When the SERVICE SELECTOR switch is set at CW, the 20 volt dc output from transistor Q1 (para 1-25) is applied through contacts 5 and 6 of switch S4, section 1, rear, to the BFO control, pin 10 of connector XA7, and pin 13 of connector XA5. The switched 20 volts dc is applied to receiver IF module 1A7 to energize the bfo circuit (para 1-12). The switched 20 volts dc is applied to transmitter IF and audio module 1A5 to disable the microphone circuits and to energize the 2 kHz generator circuit (para 1-6). When the SERVICE SELECTOR switch is set at SSB NSK or AM, the output from the vox switch is connected through contacts 10 and 11 of switch S4, section 3, front. When the SERVICE SELECTOR switch is set at CW or FSK, contacts 10 and 11 of switch S4, section 1, rear, are open to disable the vox switch for cw or fsk operation.

(3) When the SERVICE SELECTOR switch is set at STAND BY, the required standby ground for the AM-3349/GRC-106 is applied through contacts 9 and 8 of switch S4, section 2, front, and pin N of PA CONTROL connector J20. When the SERVICE SELECTOR switch is set at any operate position (SSB NSK, CW, AM, FSK), the required operate ground for the AM-3349/GRC-106 is applied through contacts 9 and 10 of switch S4 section 2, front, and pin P of PA CONTROL connector J20.

(4) When the SERVICE SELECTOR switch is set at SSB NSK, the ground on contact 9 of switch S4, section 2, front, is applied through contacts 11 and 12 of switch S4, section 2, rear, to the vox switch (*c* below). When the SERVICE SELECTOR switch is set at FSK, ground is applied through contacts 11 and 1 of switch S4, section 2, rear, to pin 5 of connector XA10 and pin 22 of connector XA5. This ground is used to disable the squelch circuit in receiver audio module 1A10 (para 1-13), and to disable the vox circuit in transmitter IF and audio module 1A5 (para 1-6). When the SERVICE SELECTOR switch is set at AM, the ground is applied to the

vox switch (*c* below) through contacts 11 and 12 of switch S4, section 2, rear, and to pin 9 of connector XA5 through contacts 11 and 2 of switch S4, section 2, rear, to energize the carrier reinsertion gate in transmitter IF and audio module 1A5 (para 1-6). When the SERVICE SELECTOR switch is set at CW, the ground is applied through contacts 11 and 1 to disable the squelch and vox circuits, as was the case during fsk operation, and through contacts 11 and 3 to pin 14 of connector XA5. This ground is used to energize the 2 kHz amplifier in transmitter IF and audio module 1A5 (para 1-6).

(5) Switch S4, section 3, front, is used in conjunction with the vox switch (*c* below).

(6) Switch S4, section 3, rear, is used to select the correct tap of voltage divider R11, R5, R6, for applying the necessary apc control voltage to transmitter IF and audio module 1A5.

c. Vox Switch S1. The vox switch, in conjunction with the SERVICE SELECTOR switch, is used to select the method in which the ground will be applied to transmitter-receiver No. 3 (tr line 3) output from transmitter IF and audio module 1A5 to place the AN/GRC-106 into the transmit mode of operation. The vox switch is operating during the ssb and am modes of operation only. During the cw and fsk modes of operation, the vox switch is bypassed.

(1) *SERVICE SELECTOR switch set at SSB NSK.*

(a) *PUSH TO TALK.* When the vox switch is set at PUSH TO TALK, the ground for keying tr line 3 is supplied by the push-to-talk switch on the H-33/PT or M-29B/U. Ground is applied to pin F of AUDIO connector J18 or J19 each time the push-to-talk switch on the M-29B/U or H-33(*)/PT is depressed. This ground is applied to contact 8 of switch S4, section 3, front, from which it is applied through contacts 8 and 6 of switch S1, rear, and contacts 10 and 11 of switch S4, section 1, rear, to contact 10 of switch S4, section 3, front. From this point, the ground is applied to pin 29 of connector XA5 to turn off transmit-receive switch 1A5A1Q11 and turn on transmit-receive switch 1A5Q1 (para 1-6), placing ground on tr line 3 (*e* below). In order to insure no hangtime when the push-to-talk switch is released, the bias developed by voltage divider 1A5A2R43, 1A5A2R44 (fig. 4-39) is applied through pin 27 of connector XA5, contacts 3 and 11 of switch S1, front, diode CR5, contacts 10 and 11 of switch S4, section 1, rear, contact 10 of switch S4, section 3, front, to pin 29 of connector XA5. Therefore, inverter 1A5A2Q11 is turned

back on as soon as the push-to-talk switch is released, turning off transmit receive switch 1A5-Q1 and removing the ground from tr line 3. This insures that the unit is placed into receive operation immediately after the push-to-talk switch is released, without any hangtime (para 1-6).

(b) *PUSH TO VOX*. When the vox switch is set at PUSH TO VOX, the ground for keying tr line 3 is produced by the voice input at the AUDIO connectors when the push-to-talk switch on the M-29B/U or H-33(*)/PT is depressed. When the push-to-talk switch is depressed, ground is applied to pin F of AUDIO connector J18 or J19. This ground is applied through contacts 8 and 9 of switch S4, section 3, front, contacts 5 and 3 of switch S1 front to pin 27 of connector XA5. Thus, vox detector 1A5A2-Q9 is enabled, allowing the voice to key the AN/GRC-106(*) (para 1-6). As long as the handset is held depressed, the hangtime function (para 1-6) is present. If the push-to-talk switch is released, the hangtime function is bypassed, immediately placing the AN/GRC-106 into receive operation. This bias on voltage divider 1A5A2R43, 1A5A2R44 is applied through pin 27 of connector XA5 to contact 3 of switch S1, front, from which it is applied through diode CR6, contacts 10 and 6 of switch S1, rear, contacts 10 and 11 of switch S4, section 1, rear, contact 10 of switch S4, section 3, front, to pin 29 of connector XA5. Therefore, transmit-receive switch 1A5A2-Q11 is turned on, which turns off transmit-receive switch 154Q1 and removes the ground from tr line 3, to bypass the hangtime function in a manner similar to the PUSH TO TALK position of switch S1.

(c) *VOX*. When the vox switch is set at VOX, the ground for keying tr line 3 is produced by the voice input present at AUDIO connector J18 and J19 (para 1-6). Ground is applied to contact 9 of switch S4, section 2, front, from which it is applied through contacts 11 and 12 of switch S4, section 2, rear, and contacts 7 and 3 of switch S1, front, to pin 27 of connector XA5. Therefore, the vox circuit will be enabled, permitting the voice to supply the ground to tr line 3 and key the AN/GRC-106(*) (para 1-6).

(2) *SERVICE SELECTOR switch set at FSK*. When the SERVICE SELECTOR switch is set at FSK, the vox switch is bypassed by opening contacts 8 and 9 of switch S4, section 3, front, and contacts 10 and 11 of switch S4, section 1, rear. The keying information is still applied to pin F of AUDIO connector J18 or J19. This information is then applied through contacts 8 and

10 of switch S4, section 3, front, to pin 29 of connector XA5. Therefore, transmit-receive switch 1A4A1A11 and transmit-receive switch 1A5Q1 will be turned off and on at the keying rate of the radio-teletypewriter terminal equipment.

(3) *SERVICE SELECTOR switch set at AM*. When the SERVICE SELECTOR switch is set at AM, the AN/GRC-106 is keyed the same as SSB NSK for the PUSH TO TALK and VOX positions of the vox switch. With the vox switch set at PUSH TO VOX, the keyline is applied through contacts 8 and 11 of switch S4, section 3, front, rather than 8 and 9 as is done in SSB NSK.

(4) *SERVICE SELECTOR switch set at CW*. When the SERVICE SELECTOR switch is set at CW, the vox switch is again disabled as it was in FSK. However, the keying information is still applied to pin F of AUDIO connectors J18 and J19. This keying information is then applied through contacts 8 and 12 of switch S4, section 3, front, to pin 30 of connector XA5, keying the vox circuit (para 1-6).

d. *Intraunit Tuning*. The turret in rf amplifier module 1A12, which contains MHz strips for the tuned input and output circuits (para 1-8 and 1-10), and the switch in MHz synthesizer module 1A9 (para 1-18), which contains crystals, capacitors and hi/lo information, are repositioned every time a change of 1 MHz or more is made in the operating frequency (2 to 29 MHz). When either MC or MHz switch (S5 or S6) is rotated, a ground is established on one contact of switch S9, front. This ground is mechanically coupled to switch S9, rear, which in turn, applies the ground to pin 7 of motor relay K2. Since 27 volts dc is applied to pin 3 of relay K2 (b above), the relay will be energized. This action removes the 27 volts dc from pin 18 of connector 1XA11, the collector of transistor 1A1Q1, and relays K1, K3, and K4. The removal of the 27 volts from pin 13 of connector 1XA11 and transistor 1A1Q1 will in turn prevent a 20 volt dc output from dc-to-dc converter and regulator module 1A11. This renders the unit inoperative while tuning is in progress. When relay K2 is energized, 27 volts dc is applied through contacts 5 and 2 of the relay to one side of turret motor B1. The other side of turret motor B1 is grounded; therefore, it will rotate. The motor drives a gear train assembly, which rotates the MHz synthesizer switch, the turret, and the rotors of switch S9. The rotation will continue until the notch in the switch rotor (S9), front reaches the grounded contact. This removes the ground from pin 7 of

relay K2, deenergizing it. When relay K2 is deenergized, the 27 volts dc is removed from motor B1 and ground is applied through contacts 4 and 2. With ground on both sides, the motor is dynamically braked. The 27 volts dc is reapplied to all operating circuits when relay K2 is deenergized. When switch S5 or switch S6 is rotated, within the operating frequency, a five-wire code is generated and applied to the AM-3349/GRC-106 to reposition the turret in that unit (para 1-

49). The two codes are generated simultaneously and are independent of each other.

e. *Tr Line 3.* During receive operation, tr line 3 is open while during transmit operation, it is grounded. When tr line 3 is grounded, relays K1, K3, K4, and K5 are energized. The ground applied to tr line 3 corresponds to system keying and is applied as outlined in table 1-3 and c above.

Table 1-3. System Keying for TR Line 3

SERVICE SELECTOR switch position	VOX switch position	Keyed by
AM or SSB NSK	PUSH TO VOX	Applied voice when the minor electrical component push-to-talk switch is depressed.
AM or SSB NSK	VOX	Applied voice.
AM or SSB NSK	PUSH TO TALK	Minor electrical component push-to-talk switch.
CW	Disabled	Cw key.
FSK	Disabled	Radioteletypewriter terminal equipment key.

(1) *Relays K3 and K4.* Initially, relays K3 and K4 are deenergized (receive operation). Relay K3 connects the input rf signal from RECEIVER IN connector J16 to rf amplifier module 1A12 (para 1-10) through coupling capacitor A7C49 and contacts A3 and A2. When energized (transmit operation), relay K3 connects the rf output from translator module 1A8 to rf amplifier module 1A12 through contacts A2 and A1 (para 1-8). Relay K4 (deenergized) connects the rf output from rf amplifier module 1A12 to translator module 1A8 through contacts A3 and A2 (para 1-10). When energized (transmit operation), relay K4 connects the rf output from rf amplifier module 1A12 to RF DRIVE connector J21 through contacts A2 and A1, in parallel with internal ALC assembly 1A1A5 (f below).

(2) *Relay K5.* During receive operation, relay K5 (deenergized), serves no function. When energized (transmit operation), relay K5 ground the rf input from RECEIVER IN connector J16.

(3) *Relay K1.* Relay K1 generates tr line 1 and tr line 2 information. When relay K1 is deenergized (receive operation), tr line 2 applies a ground (contacts 8 and 12 of relay K1) to all circuits not required for receiving, and tr line 1 applies 20 volts dc (contacts 14 and 10 of relay K1) to all circuits required for receiving. When transmitting (relay K1 energized), tr line 1 applies ground (contacts 13 and 10 of relay K1) to all circuits not required for transmitting, and tr line 2 applies 20 volts dc (contacts 9 and 12 relay K1) to all circuits required for transmitting.

f. *Internal Alc Assembly 1A1A5.* Internal Alc assembly 1A1A5 (fig. 4-31) produces a dc output corresponding to the peak voltage output from the RT-662/GRC, during the normal system operation (with an AM-3349/GRC-106). The output from this assembly is over-ridden by the automatic level control (alc) signal from the AM-3349/GRC-106 (para 1-6f and g). The output from Internal Alc assembly 1A1A5 is used to control the gain of transmitter IF and audio module 1A5 and to provide a relative indication of rf output on the front panel level meter when the RT-662/GRC is used separately from the AM-3349/GRC-106. The rf output from rf amplifier module 1A12 is applied to 1A1A5E2 through relay 1A1K4, from which it is connected to 1A1A5E4 for application to RF DRIVE connector 1A1J21 (fig. 4-33). The rf input to 1A1A5E2 is sampled and coupled by capacitor 1A1A5C1 to the anode of diode 1A1A5CR1. Diode 1A1A5CR1 peak detects the positive envelope of the signal. The output from diode 1A1A5CR1 is filtered by capacitors 1A1A5C2 and 1A1A5C4 and inductor 1A1A5L1 to remove any rf. The resulting dc output is applied to the base of emitter follower 1A1A5Q1. Emitter follower 1A1A5Q1 is used to minimize the loading on diode 1A1A5CR1 by resistor 1A1A5R3 and the input of transmitter IF and audio module 1A5. The output from emitter follower 1A1A5Q1 is processed by the low-pass filter consisting of capacitors 1A1A5C6 and 1A1A5C7 and inductor

1A1A5L3 and applied to 1A1A5E6. From 1A1A5E6, this dc level is applied to transmitter IF and audio module 1A5 for use as the internal

automatic level control signal (para 1-6f and g) when the RT-662/GRC is operating separately from the AM-3349/GRC-106.

Section VII. BLOCK DIAGRAM FUNCTIONAL ANALYSIS OF AMPLIFIER, RADIO FREQUENCY AM-3349/GRC-106

1-27. Transmit Operation, Functional Description

(fig. 4-21)

NOTE

Prefix all reference designations in *a* through *e* below with unit reference number 2, unless otherwise specified.

a. Main Signal Flow. The rf output from receiver-transmitter, is connected to RF DRIVE connector A5J3. RF DRIVE connector A5J3 connects this rf signal to the input bridge circuit. The input bridge circuit provides the necessary isolation between the receiver-transmitter and the feedback loop in Amplifier, Radio Frequency AM-3349/GRC-106. Output signals from the input bridge circuit are connected to driver amplifier A8V1, where they are raised in level and applied to power amplifier A1A1V1, A1A1V2. One of thirty tuned transformers (mounted on the motor-driven turret assembly) is connected into the output circuit of driver amplifier A8V1. The tuned transformer is automatically programmed into the circuit according to the operating frequency selected at the receiver-transmitter (para 1-49). These tuned transformers insure optimum load impedance for drive tube A8V1, providing low distortion and maximum voltage transfer. Power amplifier A1A1V1, A1A1V2 consists of two electron tubes connected in parallel then raise the rf signal level to 450 watts (pep.). The output signals from power amplifier A1A1V1, A1A1V2 are fed through phase discriminator A4A1 and load discriminator A4A2 to the antenna coupler circuits. Feedback is provided between power amplifier A1A1V1, A1A1V2 and driver amplifier A8V1 to insure linear operation. One of nineteen tuned transformers (mounted on the motor-driven turret assembly) is connected into the output circuit of power amplifier A1A1V1, A1A1V2. The transformer is automatically programmed into the circuit according to the frequency selected at the receiver-transmitter (para 1-49). These tuned transformers insure optimum load impedance on the power amplifier tubes providing low distortion and maximum power output to the antenna coupler. The antenna coupler consists of the manually tuned

antenna tuning and antenna loading circuits, and the automatically programmed (para 1-43) antenna switching circuits. When the TUNE-OPERATE switch is set to OPERATE, the power output from the antenna coupler is applied through relay A5K1 and switch A5S5 to either WHIP connector A5J6 or 50 OHM LINE connector A5J5.

b. Tuning. The phase and load discriminator circuits are each essentially a torodial transformer through which the output signals from power amplifier A1A1V1, A1A1V2 are passed to the antenna coupler circuits. Tune discriminator A4A1 senses any phase difference between the transmitted voltage and current waveforms and displays a relative indication proportional to the difference on ANT. TUNE meter A5M2. Load discriminator A4A2 senses any difference in magnitude between the transmitted voltage and current waveforms and displays a relative indication, proportional to this difference, on ANT. LOAD meter A5M3. The antenna tuning and antenna loading circuits are varied by the ANT. LOAD and ANT. TUNE controls, respectively. When the TUNE-OPERATE switch is set at TUNE, the ANT. TUNE and ANT. LOAD controls are adjusted for zero indications (center scale) on their respective meters, A5M2 and A5M3. When the ANT. TUNE meter gives a zero indication, there is no phase difference between the transmitted voltage and current waveforms. When the ANT. LOAD meter gives a zero indication, the voltage and current waveforms are in proper ratio for a 50 ohm line impedance. The antenna and the AM-3349/GRC-106 will be correctly matched in this condition for a 50-ohm resistive line impedance. A counter is mechanically coupled to the ANT. LOAD and ANT. TUNE controls to provide a reference indication, which is recorded on the LOGGING CHART for future tuning to the same operating frequency.

c. Level Control Signal Generation. Two level control signals are generated in the AM-3349/GRC-106: operate and tune. The output from power amplifier A1A1V1, A1A1V2 is envelope-detected by adapter A4A3CR1 and applied to emitter follower A4A3Q1. The modulated dc output from emitter follower A4A3Q1 is applied to pin C of CONTROL connector A5J2. This signal

is then applied to the voltage-divider network in the receiver-transmitter where it is processed and used for controlling the system gain (para 1-46). The input to power amplifier A1A1V1, A1A1V2 is also envelope-detected by detector A1A1A1CR1 and applied to emitter followers A1A1A1Q2 and A1A1A1Q1. The emitter followers provide a high shunt impedance for the detector load. The modulated dc output from the emitter followers is applied to pin B of CONTROL connector A5J2 through TUNE-OPERATE switch A5S6, when it is set at TUNE. This signal is then connected to the receiver-transmitter. The tune level control signal provides the additional control in the system gain, which is required when tuning the system (para 1-46).

d. Power Supply. When the SERVICE-SELECTOR switch on the receiver-transmitter is set at STAND BY or any operating position, a ground is applied from pin N of CONTROL connector A5J2 to the coil of relay A5A2K1. When PRIM. PWR. circuit breaker A5A2CB1 is set ON, 27 volts dc is also applied from PRIM POWER connector A5J7 to relay A5K1. This energizes relay A5A2K1 which, in turn, applies the 27 volts dc to the dc-to-dc converter assembly (part of A5) and to the dc-to-ac inverter assembly (part of

A6). These two assemblies produce all voltages used in the AM-3349/GRC-106, except the 27 volts dc. Undervoltage and overcurrent protection is provided for the dc-to-dc converter assembly.

e. Parameter Monitoring. TEST METER A5-M1 is provided to monitor various voltages and parameters of the AM-3349/GRC-106 to determine whether or not the equipment is functioning properly. TEST METER M1 provides indications of the parameters selected by TEST METER switch S2.

1-28. Receive Operation, Functional Description

(fig. 4-21)

During receive operation, any rf signal received by the antenna is applied to either WHIP connector 2A5J6 or 50 OHM LINE connector 2A5J5, depending on the antenna being used. The rf signal is applied through switch 2A5S5, and antenna switching relay 2A5K1, to RCVR. ANT. connector 2A5J4. RCVR. ANT. connector 2A5J4 is connected to RECEIVER IN connector 1A1J16 on the receiver-transmitter.

Section VIII. MAIN SIGNAL FLOW FUNCTIONAL CIRCUIT ANALYSIS OF AMPLIFIER, RADIO FREQUENCY AM-3349/GRC-106

1-29. General

Amplifier, Radio Frequency AM-3349/GRC-106 amplifies the low-level output from the transmitter section of the receiver-transmitter to a 400-watt peak-envelope-power (pep) level in voice operation (ssb or am) and 200 watts of average power in cw or fsk operation. This output can be matched to either whip or 50-ohm antenna loads.

1-30. Driver Amplifier 2A8V1

(fig. 4-16)

NOTE

Prefix all reference designators in this paragraph with driver assembly reference designator 2A8, unless otherwise specified.

a. Driver amplifier 2A8V1 amplifies the low-level output from the receiver-transmitter to a level suitable for driving power amplifier 2A1A1V1, 2A1A1V2 (para 1-31). The output from the receiver-transmitter is applied to RF DRIVE connector 2A5J3 on the front panel. From here, it is

routed through connectors 2A5J1-A1, 2A1XA5-A1, 2A1A1XA8-A4, J1-A4, and P1 to connector A1J1. From connector A1J1, the rf input signal is applied to an input bridge (fig. 1-8). The input bridge algebraically sums the rf input with an inverse feedback signal that is proportional to the output from power amplifier 2A1A1V1, 2A1A1V2 (fig. 4-23). The inverse feedback maintains the gain characteristics of the AM-3349/GRC-106 relatively constant over the entire range of transmitted frequencies. It also increases the linearity, thereby reducing the intermodulation distortion.

b. The rf input is coupled by capacitor A1C1 to the primary of transformer A1T1, and coupled by transformer action to the secondary of transformer A1T1. Resistor A1R1 provides the proper termination for the rf input signal. The primary of transformer A1T1 is tuned by capacitor A1C1 and the secondary of transformer A1T1 is tuned by capacitor A1C2, the interelectrode capacity Cgk, and the stray capacity of the transformer. Both the primary and secondary windings of

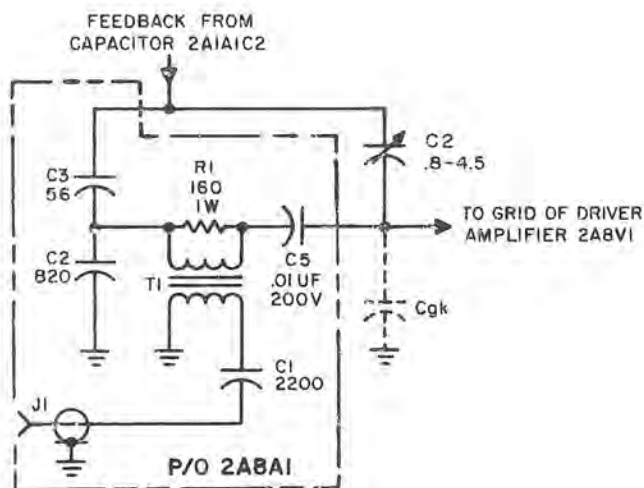

NOTE:
Cgk REPRESENTS THE GRID-TO-CATHODE INTERELECTRODE CAPACITANCE OF DRIVER AMPLIFIER 2A8V1.

TM5820-520-35-608

Figure 1-8. Driver amplifier 2A8V1, input bridge, schematic diagram.

transformer A1T1 are tuned to the geometric center (8 MHz) of the passband. This provides a broadband tuned input for operating frequencies between 2 and 30 MHz and minimizes the vswr on the input line.

c. The feedback signal from the plates of power amplifier 2A1A1V1, 2A1A1V2 is applied to connector J1-A1 (para 1-31), from which it is applied to the junction of capacitors A1C3 and C2. Normally, the feedback is 180° out of phase with the rf input. The feedback signal is divided by the capacitive divider arms of the bridge: A1C2, A1C3, and C2, CGK. When the bridge is balanced, a very small portion of the feedback signal appears across the secondary of transformer A1T1. However, the low reactance of capacitor A1C2 causes the rf input signal at the secondary of transformer A1T1 to appear between the grid of driver amplifier V1 and ground. This rf input signal is algebraically summed with the feedback signal. The resultant signal (the net difference) is coupled by capacitor A1C5 to the grid of driver amplifier V1. Capacitor C2 is adjusted for best bridge balance at the worst conditions of CGK (30 MHz). Since the signal applied to driver amplifier V1 is the difference between two relatively large signals, it is evident that, given a constant rf input, a small change in feedback will produce a large change in the signal applied to the grid of driver amplifier V1. It is also evident that this change will, in effect, minimize

the original change in the feedback signal as a result of the system gain. The feedback signal is directly related to the input by the gain factor of the AM-3349/GRC-106. Therefore, moderate changes in the regulated supply voltages resulting from temperature variations, or changes in tube or component characteristics that would normally have great effect on the overall gain and sensitivity, will be minimized.

d. The output from the input bridge is raised in level by driver amplifier V1 and is developed across 1 of 30 interstage tuned circuits, which form a part of Turret assembly 2A2. These tuned circuits are mounted on a motor-driven turret and are automatically programmed into the circuit according to the operating frequency (para 1-49). The output from the tuned circuit is applied to connectors J1-A2 and J1-A3 for application to power amplifier 2A1A1V1, 2A1A1V2. Capacitor C6 is adjusted to compensate for the input capacitance of power amplifier 2A1A1V1, 2A1A1V2, and the output capacitance of driver amplifier V1. This prevents mistuning to insure optimum power transfer.

e. The 500-volt dc output from the dc-to-dc converter assembly (part of 2A5) is regulated to 200 volts dc by Zener diode 2A1A1VR3 (fig. 4-49). This regulated 200 volts dc and the 27-volt dc primary power are used to develop the operating voltages for driver amplifier V1. The 27 volts dc, applied to pin 3 of connector J1 (fig. 4-16), is regulated to 15 volts dc by Zener diode A2VR1 and applied across resistors A2R5 and A2R6. A portion of this voltage is applied through isolating resistor A2R2 to the grid of driver amplifier V1 as a fixed bias. Driver amplifier V1 also develops a self-bias across resistors A2R3 and A2R4. This combination of biasing results in a cathode dc load line (on the transfer characteristics) that has a very shallow slope with respect to using either the self-biasing method or fixed-biasing method alone. Therefore, changes in tube characteristics will have only a minimum effect on the operating point of driver amplifier V1. Capacitors A2C6, A2C7, and A2C8 are rf bypass capacitors. Capacitors A2C9 and A2C10 are audio bypass capacitors, used to reduce intermodulation distortion when voice transmissions are being made. The 200 volts dc present at pin 1 of connector J1 is used as the plate supply for driver amplifier V1 and is regulated to 164 volts dc by Zener diodes VR1 and VR2 for use as the screen supply for driver amplifier V1.

1-31. Power Amplifier 2A2A1V1, 2A2A1V2

(fig. 4-49)

NOTE

Prefix all reference designators in this paragraph with chassis reference designator 2A1, unless otherwise specified.

a. Power amplifier A1V1, A1V2 amplifies the output from driver amplifier 2A8V1 to a level of approximately 450 watts pep. for application to the impedance-matching networks in antenna coupler assembly 2A3. The output from driver amplifier 2A8V1 is coupled by the interstage tuned transformer (2A2A16 through 2A2A30) to the neutralization bridge (fig. 1-9). The neutralization bridge is used to compensate for the feedback between the output and input of power amplifier A1V1, A1V2 through the interelectrode capacitance. One leg of the bridge is composed of the two interelectrode capacities C_{pg} and C_{gk} . The other leg of the bridge is composed of capacitors A1C3, A1C4, and A1C24. Capacitor A1C4 is adjusted so that the voltage developed across each leg of the bridge is equal in magni-

tude to $(\frac{C_N}{A1C24} = \frac{C_{pg}}{C_{gk}})$. C_N is equal to A1C3

times A1C4 divided by A1C3 plus A1C4. Therefore, since the voltages in the two legs are in phase with each other, the feedback will be cancelled and the input to the grids of power amplifier A1V1, A1V2 will be the output from driver amplifier 2A8V1. Resistor A1R8 provides the correct termination for the rf input signal. The amount of feedback to driver amplifier 2A8V1 is determined by capacitor A1C2.

b. The output from the neutralization bridge is coupled by capacitors A1C5, A1C18, A1C6, and A1C19 to the control grids of power amplifier A1V1, A1V2. Power amplifier A1V1, A1V2 consists of two electron tubes connected in parallel to raise the level of the output from driver amplifier 2A8V1 to a level of 450 watts. This rf output from power amplifier A1V1, A1V2 is developed across 1 of 19 tuned transformers mounted on motor-driven turret assembly 2A2. The transformer in the circuit depends on the frequency of the operating channel. The auto-

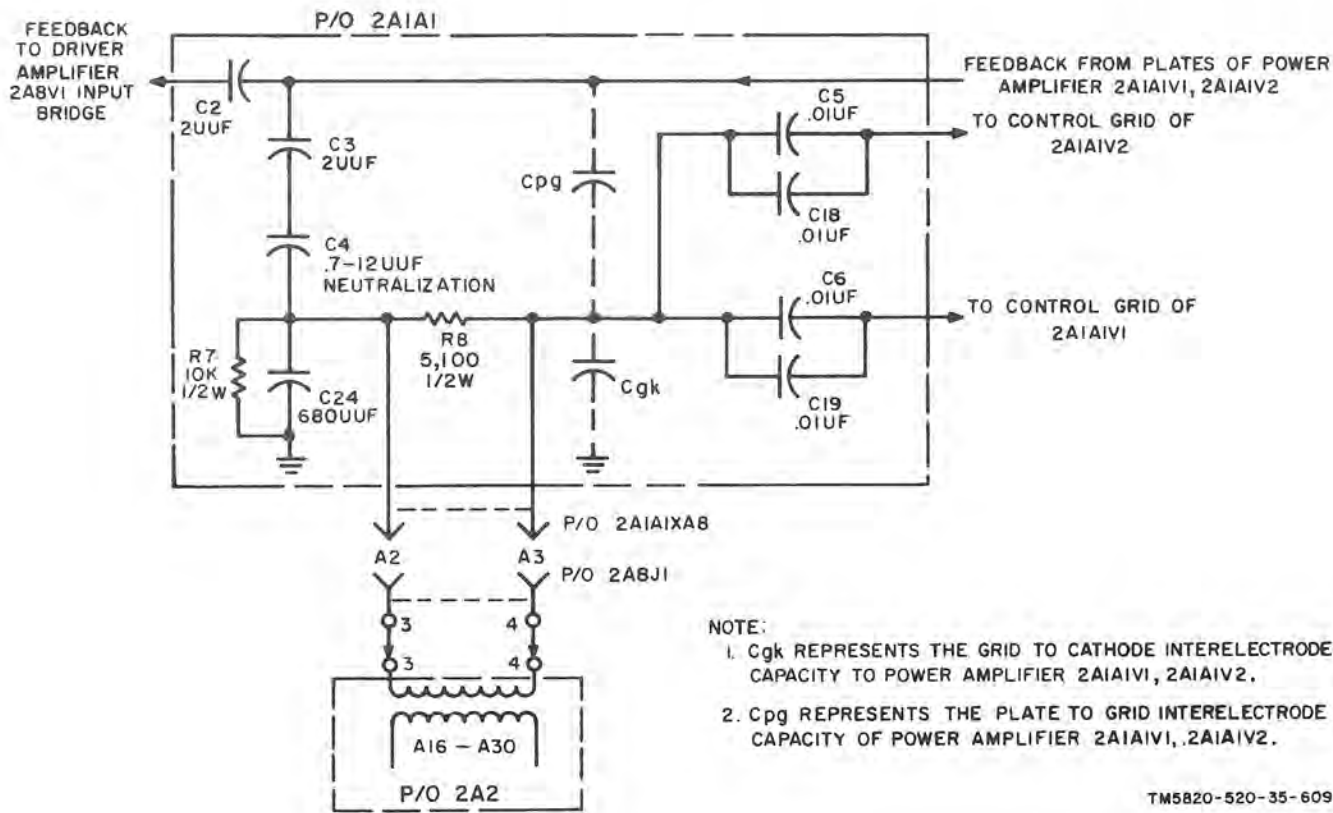

Figure 1-9. Power amplifier 2A1A1V1 and 2A1A1V2, neutralization bridge, schematic diagram.

matic tuning system automatically switches the correct transformer into the circuit (para 1-49). The required capacitance for tuning the primary and secondary of the transformer used is mounted on Stator Assembly 2A9. Capacitor 2A9C3 is adjusted so that at 30 MHz, capacitor 2A9C2D will exactly equal 90 micromicrofarads ($\mu\mu\text{f}$). Capacitor A1C22 is adjusted to compensate for the output capacity of power amplifier A1V1, A1V2. The output from power amplifier A1V1, A1V2 is applied through connectors 2A9J1B, 2A1XA9B, and 2A1P1 and discriminator assembly 2A4 to the antenna coupler.

c. The 2,400-volt dc output from dc-to-dc converter assembly 2A5A2 is applied through the primary of the transformer and switched into the output circuit of power amplifier A1V1, A1V2 to the plates of power amplifier A1V1, A1V2. The screen voltage for power amplifier A1V1, A1V2 is developed from the 500-volt dc output from dc-to-dc converter assembly 2A5A4. This 500 volts dc is regulated to 400 volts dc by Zener diodes A1VR1 and A1VR2. The 500 volts dc is also regulated to 200 volts dc by Zener diode A1VR3. This 200 volts dc is used as the required plate and screen supply for driver amplifier 2A8V1. The bias for power amplifier A1V2, A1V2 is developed from the -100 volt dc output from dc-to-ac inverter assembly 2A6A1. This -100 volts dc is regulated to a -40 volts dc by Zener diodes A1A1VR2 and A1A1VR3. Potentiometer A1A1R5 is used to adjust the amount of bias applied to tube A1V2 and potentiometer A1A1R6 is used to adjust the bias applied to tube A1V1. The arrangement of Zener diodes A1A1VR2 and A1A1VR3 and potentiometers A1A1R5

and A1A1R6 is such that the bias to the two tubes can be varied from -40 to -20 volts dc. The two separate adjustments are used to insure that both tubes are at the same operating point and share the load during operation.

1-32. Antenna Coupler Assembly 2A3

(fig. 4-51)

Antenna coupler assembly 2A3 is a semiautomatic, impedance-matching network consisting of manually and automatically programmed parts. This network matches the impedance of the system antenna to the 50 ohm output impedance of power amplifier 2A1A1V1, 2A1A1V2, at the desired operating frequency. Bandswitch 2A3S1 is automatically programmed (para 1-40) to rough-tune the AM-3349/GRC-106 so that it is within the tuning range of the manually variable circuit (2A3L1, 2A3C26). After antenna coupler assembly 2A3 is programmed, ANT. LOAD control 2A3L1 is adjusted so that power amplifier 2A1A1V1, 2A1A1V2 looks into an impedance of 50 ohms. Capacitor 2A3C26 is adjusted so that the phase angle of the impedance is zero. Therefore, after tuning, power amplifier 2A1A1V1, 2A1A1V2 works into the desired resistive load of 50 ohms. Figure 1-10 illustrates the circuitry according to the operating frequency. The rf power output applied through relay 2A5K1 (energized when transmitting) and switch 2A5S5 to WHIP connector 2A5J6 or 50 OHM LINE connector 2A5J5, depending on whether a whip or doublet antenna is being used. From the connector being used, the power is connected to the antenna for propagation.

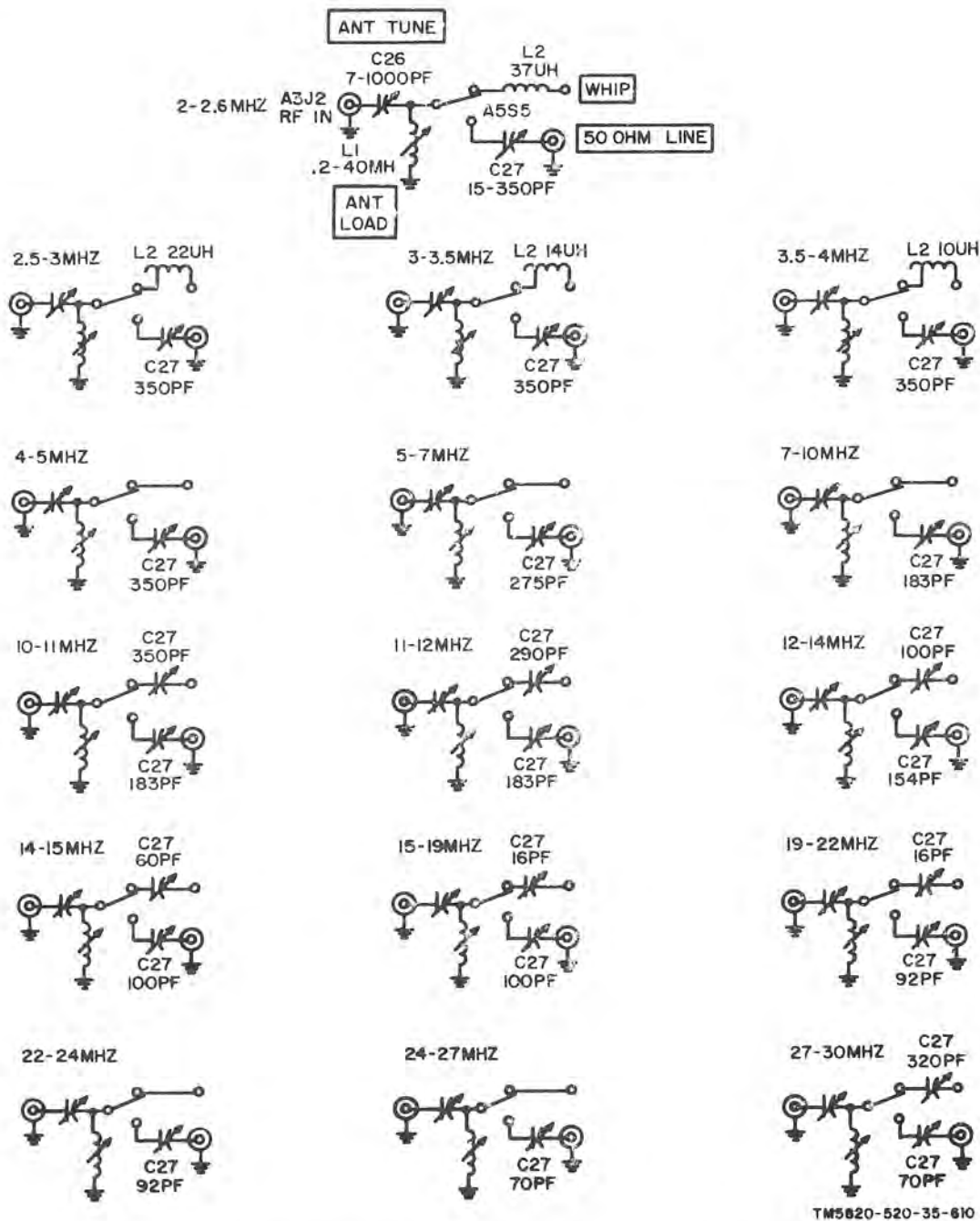

Figure 1-10. Antenna coupler assembly 2A3, bandswitching simplified circuits.

**Section IX. POWER CONTROL AND PROTECTION CIRCUIT
FUNCTIONAL ANALYSIS FOR AMPLIFIER, RADIO FREQUENCY
AM-3349/GRC-106**

1-33. General

Primary power for Amplifier Radio Frequency AM-3349/GRC-106 is the +27 volts ± 3 vehicular supply. This 27 volt supply is applied to assembly 2A6A1 and the dc-to-dc converter as-

sembly (part of 2A5). These two assemblies develop all voltages required internally, except the 27 volts dc. The dc-to-ac inverter assembly (para 1-34) produces outputs of 6.3 volts ac, 128 volts ac, and -110 volts dc. The dc-to-dc converter assembly (para 1-35) produces out-

puts of 2,400 volts dc and 500 volts dc. This assembly is provided with overcurrent (para 1-36) and undervoltage (para 1-37) protection.

1-34. Dc-to-Ac Inverter Assembly 2A6A1

(fig. 4-54)

NOTE

Prefix all reference designations in this paragraph with dc-to-ac inverter assembly reference designations 2A6A1, unless otherwise specified.

a. The dc-to-ac inverter assembly utilizes a saturable-core transformer oscillator circuit to develop a square-wave ac output from the 27-volt dc input. When the receiver-transmitter SERVICE SELECTOR switch is at STAND BY or any operating mode (AM, CW, FSK, SSB/NSK) and Amplifier, Radio Frequency AM-3349/GRC-106 PRIM. PWR. circuit breaker is at ON, 27 volts P1 (para 1-47). This 27 volts dc is applied to pin 4 of transformer T1 and through current-limiting resistor R1 to pin 1 of transformer T1 (fig. 4-54). From pin 4, 27 volts dc is applied through primary winding 4-3 to the collector of switch Q1 and through primary winding 4-5 to the collector of switch Q2. From pin 1, 27 volts dc is applied through feedback winding 1-2 and current-limiting resistor R2 to the base of switch Q1 and through feedback winding 1-6 and current-limiting resistor R3 to the base of switch Q2. These applications are simultaneous, and both transistors will be forward-biased. However, due to inherent differences in components and circuit unbalance, one transistor will start conducting first. For purposes of this discussion, assume the switch Q1 starts conducting first.

b. When switch Q1 starts conducting, the voltage at pin 3 of transformer T1 will begin to decrease. This will induce a voltage across winding 4-3 with pin 4 positive and pin 3 negative, which will create a field through the transformer core with the same polarity. Therefore, since pin 1 of transformer T1 is referenced to ground through diode CR1, the polarity of the field around the core will cause the level at pin 2 to rise and the level at pin 6 to decrease. As long as the level at pin 6 is decreasing (or negative with respect to pin 1), switch Q2 will be reverse-biased. As long as the level at pin 2 is increasing (or positive with respect to pin 1), switch Q1 will be driven toward saturation. When switch Q1 reaches saturation, the voltage induced across

winding 4-3 will stabilize. This condition (Q1 saturated; Q2 cut off) will continue until the transformer core reaches saturation. At this point, the field around the core will collapse. This will induce voltages in the primary and feedback windings of opposite polarity to that just described. Therefore, the level at pin 2 will decrease and the level at pin 6 will increase. When the level at pin 2 decreases, switch Q1 is cut off. When the level at pin 6 increases, switch Q2 is forward-biased and starts conducting. When switch Q2 starts conducting, the level at pin 5 decreases. The voltage induced across winding 4-5 by this decrease is of the same polarity as that induced by the collapsing field; therefore, a new field is developed around the transformer core with the same polarity. Since pin 1 of transformer T1 is referenced to ground through diode CR1, the level at pin 2 will continue to decrease, holding switch Q1 cut off, and the level at pin 6 will continue to increase, driving switch Q2 toward saturation. When switch Q2 reaches saturation, the voltage induced across winding saturation, the voltage induced across winding 4-5 will stabilize. This condition (Q1 cut off; Q2 saturated) will continue until the core is again saturated. At this time, the field will collapse. Switch Q1 will be driven to saturation and switch Q2 will be cut off. The oscillations caused by this process produce a square-wave ac output. The output is a square wave because a square hysteresis loop material is used in the core of the transformers. The frequency of the ac output, which is determined by the saturation time of the transformer core, is approximately 400 Hz. Any transients or spikes produced at the collector of either switch by the instantaneous transfer from cutoff to saturation are applied through either diode CR2 or CR3 to Tenor diode VR1. If these peaks exceed 68 volts, Zener diode VR1 will fire, shunting the peaks to ground.

c. There are three outputs from the dc-to-ac inverter assembly: 6.3 ac, 128 volts ac, and -110 volts dc. The 6.3 volts ac, 400 Hz driver amplifier 2A8V1 filament supply is developed across winding 7-8 and applied to pins 5 and 6 of connector P1. The voltage developed across winding 9-13 is applied across bridge rectifier CR4, CR5, CR6, and CR7. The -100-volt dc output from the bridge rectifier is applied to pin 13 of connector P1 to be used as the bias supply for power amplifier tubes 2A1A1V1 and 2A1A1V2. The voltage devel-

oped across winding 9-13 is also applied to pins 1 and 2 and pins 9 and 10 of connector P1. From pins 1 and 2, the 400 Hz 128 volts ac is applied to the internal blower motor on the main frame plenum. Pin 9 of connector P1 is connected to one side of the external blower motor on the case. Winding 9-13 is tapped, and this line is applied to pin 11 of connector P1. Pins 10 and 11 of connector P1 are connected to thermostat 2A6S1. Thermostat 2A6S1 is connected to the other side of the external blower motor. While the temperature in the case is below 75° C., the voltage between pins 9 and 11 of connector P1 is applied to the external blower motor. If the temperature in the case exceeds 75° C., the 128 volts ac between pins 9 and 10 of connector P1 is applied to the external blower motor, which will increase its speed to provide more airflow. Pins 7 and 8 of connector P1 are jumpered to provide an interlock so that if the dc-to-ac inverter is disconnected, the groundpath to standby relay 2A5A2K2 is broken. Therefore, no power can be applied to the power amplifier tube filaments, if dc-to-ac inverter 2A6A1 is disconnected.

1-35. Dc-to-Dc Converter Assembly (Part of 2A5)

(fig. 4-53)

NOTE

Prefix all reference designations in this paragraph with the front panel assembly reference designation 2A5, unless otherwise specified.

a. When Amplifier, Radio Frequency AM-3349/GRC-106 PRIM. PWR. circuit breaker 2A2CB1 is set at ON and the receiver-transmitter, SERVICE SELECTOR switch is set at any operate setting (AM, CW, FSK, SSB, NSK), 27 volts dc is applied to the following points: switch Q1 collector, switch A2Q2 collector, pins 4 and 7 of relay A2K2, terminal A3E17, switch A6Q1 collector, pin 3 of relay A3K2, pin 4 of relay A3K3, capacitor A7C8, and pin 1 of relay K1 (para 1-47).

b. The 27 volts dc at contact 4 of relay A2K2 is applied through contact 2 to charge capacitor A6C1 while relay A2K2 is deenergized. When the radio set is keyed, the keyline ground is applied to pin N of CONTROL connector J2, through contacts 5 and 1 of relay A3K3 (deenergized) to pin 3 of relay A2K2. Since 27 volts dc is applied to pin 7 of relay A2K2 (a above), the relay will energize.

When relay A2K2 is energized, the converter feedback path is completed through contacts 1 and 6 of relay A2K2 and capacitor A6C1 discharges through contacts 2 and 5 of the relay, the parallel combination of resistor A6R4 and resistor A6R5, and the base-emitter junction of switch A6Q1. Twenty-seven volts dc is applied to the collector of switch A6Q1 (a above); therefore, when capacitor A6C1 discharges, switch A6Q1 is forward-biased and conducts. The conduction of switch A6Q1 causes current flow through resistor A6R3 and the base-emitter junction of switch A2Q2. Since 27 volts dc is applied to the collector of switch A2Q2, the base circuit starts a flow of collector current. When switch A2Q2 starts conducting, the level at pin 3 of transformer A2T1 will decrease. This will induce a voltage across winding 2-3, which results in a voltage being induced across winding 8-10 of transformer A2T1. This voltage is applied across pins 1 and 3 of transformer A2T2 through contacts 1 and 6 of relay A2K2 (energized). The field developed as a result of this voltage induces a voltage across the secondary of transformer A2T2 so that pin 4 is positive and pin 5 is negative. The positive level at pin 4 is applied to the base of switch A2Q2, which drives switch A2Q2 into saturation. The negative level at pin 6 holds switch Q1 at cutoff. When switch A2Q2 reaches saturation, the voltages induced in the various windings stabilizes until the core of transformer A2T2 is saturated. At this time, the field around transformer A2T2 collapses; the polarities at pin 4 and 6 reverse, switch A2Q2 is cut off, switch Q1 is driven into saturation, and the process if repeated in essentially the same way as described for the dc-to-ac inverter assembly (para 1-34). In this way, a square-wave ac output is developed at the secondaries of transformer A2T1.

c. There are three outputs from transformer A2T1. The signal across winding 8-10 is the feedback signal applied to transformer A2T2. The signal across winding 6-7 is rectified by bridge rectifier A4CR1, A4CR2, A4CR3 and A4CR4. The resulting 500 volts dc is applied to pin 1 of connector J1 to be used as the plate and screen grid supply for driver amplifier 2A8V1 and the screen grid supply for power amplifier 2A1A1V1, 2A1A1V2. A representative portion of this voltage is applied to the front panel TEST METER circuit (para 1-44). The signal across winding 4-5 is rectified by bridge rectifier unit A2CR6, and the

resulting 2,400 volts dc is applied to pin A4 of connector J1 to be used as the plate supply for power amplifier tubes 2A1A1V1 and 2A1A1V2. A representative portion of this voltage is applied to the front panel TEST METER circuit (para 1-44). The power amplifier (pa) plate current flows through resistor A5R1, and the resultant voltage drop is applied to the front apanel TEST METER circuit to provide an indication of pa plate current when desired (para 1-44).

d. When the AN/GRC-106(*) is unkeyed, the feedback path through contacts 1 and 6 of relay A2K2 is broken and the oscillations stop. At this time, 27 volts dc is applied through contacts 4 and 2 of relay A2K2 to capacitor A6C1. Capacitor A6C1 will recharge to the supply voltage and when the AN/GRC-106(*) is keyed again, the process described in *b* above is repeated.

1-36. Overcurrent Protection Circuit

(fig. 4-53)

NOTE

Prefix all reference designations in this paragraph with front panel assembly reference designation 2A5 unless otherwise specified.

a. The dc-to-dc converter assembly is provided with an overcurrent protection circuit that will turn off the dc-to-dc converter when the power amplifier tubes draw plate current in excess of approximately 450 milliamperes (ma) for approximately 200 milliseconds (ms).

b. When the radio set is keyed, the ground keyline is applied through contacts 5 and 1 of relay A3K3 (deenergized) to pin 3 of relay A2K2 to start dc-to-dc converter (para 1-35b). If power amplifier 2A1A1V1, 2A1A1V2 draws excess plate current, relay A3K1, which is in the plate current return path, will be energized. When relay A3K1 is energized, the 20-volt dc output from regulator A3VR1 is applied through contacts 2 and 5 of the relay and feedthrough capacitor A7C5 to the combination of resistor A7R7 and capacitor A7C14 (fig. 2-19). The time constant of this re combination is such that after approximately 40 ms, the charge on capacitor A7C14 will exceed 10 volts dc. This will cause Zener diode A7VR3 to fire. When Zener diode A7VR3 conducts, current flows through resistor A7R8. This current flow creates a positive potential

across resistor A7J8. This potential is applied to silicon-controlled rectifier (scr) A7Q2 to fire it. Since the coil of relay A3K3 is apart of the conduction path for scr A7Q2, when the positive potential is applied to scr A7Q2 and the scr conducts, relay A3K3 is energized. When relay A3K3 is energized, the ground keyline to relay A2K2 (above) is broken, which deenergizes relay A2K2. When relay A2K2 is deenergized, the feedback path from transformer A2T1 to transformer A2T2 is opened, which turns off the dc-to-dc converter assembly.

c. This condition (*b* above) will continue until the AN/GRC-106(*) is reset (conduction path for scr A7Q2 broken) by switching TUNE-OPERATE switch S6 from one position to the other. This will turn off scr A7Q2; relay A3K3 will be deenergized; and the ground keyline will again be completed.

1-37. Undervoltage Protection Circuit

(fig. 4-53)

NOTE

Prefix all reference designations in this paragraph with front panel assembly reference designation 2A5, unless otherwise specified.

a. The dc-to-dc converter assembly is provided with an undervoltage protection circuit that will turn off the dc-to-dc converter whenever the output voltage from the dc-to-dc converter is below a predetermined level.

b. While the dc-to-dc converter assembly is turned off, no feedback voltage is at pins 1 and 3 of transformer A2T1, no signal is applied to the cathode of Zener diode A7VR2, and the cathode of Zener diode A7VR1 is held essentially at ground through contacts 8 and 6 of relay A2K2 and winding 2-3 of transformer A2T1. When the AN/GRC-106(*) is keyed, the dc-to-dc converter assembly is turned on (para 1-35b). The feedback signal is detected by diodes A3CR1 and A3CR2, and the resultant output is applied through isolating resistor A3CR1 and A3CR2, and the resultant output is applied through isolating resistor A3R1 and feedthrough capacitor A7C3 to the cathode of Zener diode A7VR2. Under normal operation, the level at the cathode of Zener diode A7VR2 is of sufficient amplitude to fire Zener diode A7VR2 (within approximately 30 milliseconds from the instant the dc-to-dc

converter is keyed). This will supply enough current through the base-emitter junction of switch A7Q1 to keep switch A7Q1 conducting in saturation. Since the coil of relay A3K2 is in the conduction path for switch A7Q1, when switch A7Q1 is saturated, relay A3K2 is energized. This condition will continue as long as the operation of the dc-to-dc converter assembly is normal.

c. When the radio set is keyed and the dc-to-dc converter assembly is turned on (para 1-35b), the ground at the junction of resistors A7R1 and A7R2 is removed (contacts 6 and 8 of relay A2K2 opened). The 20-volt output from regulator A3VR1 is then applied to the rc combination of resistors A7R1 and A7R2 and capacitor A7C10. The time constant for this rc combination is such that after 130 MHz, the charge on capacitor A7C10 will reach 10 volts. However, as long as relay A3K2 is energized (b above), there is no conduction path for Zener diode A7VR1.

d. If the output voltage from the dc-to-dc converter assembly should decrease, the feedback voltage will also decrease. If the voltage at capacitor A7C3 drops below approximately 10 volts, Zener diode A7VR2 will stop conducting. Therefore, the base-to-emitter junction of switch A7Q1 will be reverse-biased and stop conducting. Diode A7CR1 in the emitter circuit of switch A7Q1 provides reverse biasing to hold switch A7Q1 nonconducting when Zener diode A7VR2 is not conducting. At this time, relay A3K2 is deenergized, and a conduction path is provided for Zener diode A7VR1 (c above) through feedthrough capacitor A7C4, inductor A7L1, and resistor A7J8. This fires scr A7Q2 and the dc-to-dc converter assembly is turned off as described in paragraph 1-35c. Normal operation can be resumed, after the faulty condition is repaired, by resetting the AN/GRC-106(*) as described in paragraph 1-36c.

Section X. OPERATIONAL CONTROL FUNCTIONAL CIRCUIT ANALYSIS OF AMPLIFIER, RADIO FREQUENCY AM-3349/GRC-106

1-38. General

a. The operational control circuits of Amplifier, Radio Frequency AM-3349/GRC-106 provide the following control functions: detection of phase difference between the rf output voltage and current for fine tuning; detection of magnitude difference between the rf output voltage and current for fine tuning; generation of the operate automatic level control signal; generation of the tune automatic level control signal; coding required to rough-tune the impedance-matching networks in antenna coupler assembly 2A3; and metering to monitor the important parameters of the circuits. Paragraphs 1-39 through 1-44 provide a detailed description of these circuits.

b. The two discriminator circuits enable the AM-3349/GRC-106 to be fine-tuned to provide a 50 ohm pure resistive load for the output transformers of power amplifier 2A1A1V1, 2A1A1V2. This provides maximum rf power and maximum efficiency to prevent overdissipation.

1-39. Tune Discriminator 2A4A1 (Meter 2A5M2)

a. When the AM-3349/GRC-106 is correctly tuned (50 ohm resistive load), the rf output voltage and current are in phase with each other. When the output load is reactive,

tune discriminator 2A4A1 (fig. 4-52) detects the resulting phase angle between the rf output voltage and current and produces a dc voltage proportional to the phase difference. This dc voltage is applied to meter 2A5M2 (fig. 4-53) on the front panel to provide a relative indication of the magnitude of phase difference for fine tuning.

NOTE

Prefix all reference designators in the following subparagraphs with phase discriminator reference designator 2A4A1, unless otherwise specified.

b. The rf output from power amplifier 2A1A1V1, 2A1A1V2 is applied to connector 2A1P1 (para 1-31), from which it is applied through connectors 2A4J1 and 2A4P1 to connector J1 (fig. 4-52). This cable passes through toroidal transformer T1. Since toroidal transformer T1 is center-tapped, the rf output current will induce a voltage in each half of the winding. These voltages, designated E1 and E2, will be of equal magnitude, 90° out of phase with the rf output current, and 180° out of phase with each other. The rf output voltage is sampled across a capacitance voltage divider consisting of capacitors C4 and C1. This voltage, which is vectorially in phase

with the rf output voltage, is applied to the center tap of toroidal transformer T1. The vectoral summation of the sampled voltage (E_s) and induced voltage E_1 is detected by diode CR1, producing a dc voltage E_1' at the cathode of diode CR1. Similarly, the vectoral summation of E_s and E_2 is detected by diode CR2, producing a dc voltage E_2' at the cathode of diode CR2. Voltage E_1' is applied 2A1P2, pin 28 of connectors 2A1XA5 and 2A5J1, and resistor 2A5A5R8 to one side of ANT. TUNE meter 2A5M2. Voltage E_2' is applied through pin 7 of connectors 2A4J2 and 2A1P2 and pin 29 of connectors 2A2SA5 and 2A5J1 to the other side of ANT. TUNE meter 2A4M2.

c. If the impedance of the rf output line is resistive, the rf output voltage and current will be in phase. Therefore, the two vectoral summations will result in E_1' and E_2' being equal ((a), Fig. 1-11), and there will be no difference in voltage across ANT. TUNE meter 2A5M2. The meter will then indicate center scale, 0° phase difference between the rf output voltage and current. If the impedance of the rf output line is inductive, the rf output current will lag the rf output voltage by some angle θ . Therefore, as shown in (b), figure 1-11, E_1' will be greater than E_2' , causing ANT. TUNE meter 2A5M2 to deflect to the left of center. The degree of deflection will be proportional to the phase difference between the rf output current and voltage. If the impedance of the rf output line is capacitive, the rf output current will lead the rf output voltage by some angle θ . Therefore, as shown in (c), figure 1-11 E_1' will be less than E_2' , causing ANT. TUNE meter 2A5M2 to deflect to the right of center. The degree of deflection will be proportional to the phase difference between the rf output voltage and current. The phase angle is corrected by varying the value of capacitor 2A3C26 (para 1-37), when TUNE-OPERATE switch 2A5S6 is set at TUNE. When TUNE-OPERATE switch 2A5S6 is set at TUNE, E_1' is applied through contacts C2 and 4 of switch 2A5S6. This path changes the sensitivity of meter 2A5M2 by bypassing resistor 2A5A5R8.

d. Inductor L1 provides a dc return for capacitors C1 and C4. The values of these components are such that they are not frequency-sensitive within the operating passband of the AM-3349/GRC-106. Capacitors C2 and C3 are rf bypasses. Resistors R1 and R2 provide

a dc path for diodes CR1 and CR2, respectively. Resistor R3 is an equalizing resistor to make the dc output from the phase discriminator the same as the output from the load discriminator (para 1-40). Capacitor 2A5C5 bypasses any rf present in the meter voltage around meter 2A5M2.

1-40. Load Discriminator 2A4A2

(fig. 4-52)

a. When Amplifier, Radio Frequency AM-3349/GRC-106 is correctly loaded (50 ohm impedance), the rf output voltage and current are of the correct magnitude to produce an output of 400 watts pep. If the load for the AM-3349/GRC-106 is greater or less than 50 ohms, the rf output voltage and current will no longer be of the correct magnitude to produce a 400-watt pep. output. This difference in magnitude is detected by the load discriminator, which produces a dc output proportional to the difference. The resulting dc voltage is applied to ANT. LOAD meter 2A5M3 on the front panel to provide a relative indication of this difference in magnitude for fine tuning.

NOTE

Prefix all reference designators in this paragraph with load discriminator reference designator 2A4A2, unless otherwise specified.

b. The rf output from power amplifier 2A1A1V2, 2A1A1V2 is applied through tune discriminator 2A4A1 (para 1-39) to connector 2A4A1J4. From this point, the power output is connected through connector P1 and the load discriminator to connector J1. The current flow in this line induces a voltage in toroidal transformer T1. This induced voltage is detected by diode CR2, producing a dc voltage, which is applied through pin 2 of connectors 2A4J2 and 2A1P2, pin 30 of connectors 2A1XA5 and 2A5J1, to one side of ANT. LOAD meter 2A5M3. The rf output voltage is sampled by capacitive divider C1, C2 and detected by diode CR1 to produce a dc voltage, which is applied through pin 8 of connectors 2A4J2 and 2A1P2, pin 31 of connectors 2A1XA5 and 2A5J1, and resistor 2A5A5R7 to the other side of ANT. LOAD meter 2A5M3. When the impedance of the rf output line equals 50 ohms, capacitor C1 is adjusted so that the voltage at pin 8 of connector 2A4J2 is equal in magnitude to the voltage at pin 2 of connector 2A4J2. If the load impedance differs

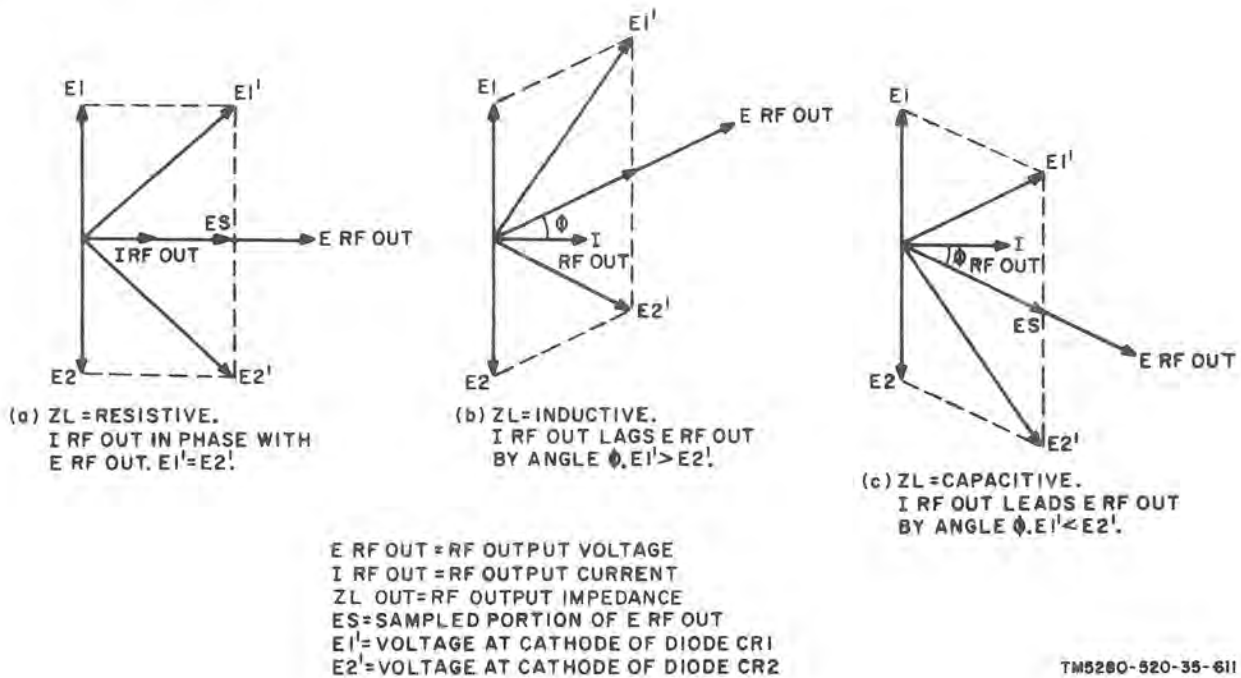

Figure 1-11. Phase discriminator 2A4A1, vector diagram.

from the desired 50 ohms, the voltages at pins 8 and 2 of connector 2A4J2 will differ. The amount of difference will be proportional to the degree of variation from 50 ohms. These two voltages will cause ANT. LOAD meter 2A5M3 to deflect either right or left from center scale, indicating that the load must be decreased or increased to reach the 50 ohm balance point. The load is varied by varying the value of inductor 2A3L1, when TUNE-OPERATE switch 2A5S6 is set at TUNE. When TUNE-OPERATE switch 2A5S6 is set at TUNE, the voltage at pin 2 of connector 2A4J2 is applied through contacts C3 and 6 of switch 2A5S6. This new path changes the sensitivity of ANT. LOAD meter 2A5M3 by bypassing resistor 2A5A5R7.

c. Resistor R1 provides a dc return for capacitors C1 and C2. Resistor R3 is a swamping resistor for toroidal transformer T1 to minimize the effects of frequency variations. Capacitors C3 and C4 are rf bypasses. Resistors R2 and R4 provide a dc path for diodes CR1 and CR2, respectively. Capacitor 2A5C6 bypasses any rf present in the voltage applied to meter 2A5M3.

1-41. Operate Automatic Level Control Signal Generation (fig. 4-52)

a. The output from the AM-3349/GRC-106 is sampled and detected to provide a dc signal to the receiver-transmitter, to control the output from the receiver-transmitter (para 1-6 and 1-46). The output from power amplifier 2A1A1V1, 2A1A1V2 is applied through the tune discriminator (para 1-39) and load discriminator (para 1-40) to connector 2A4A3P1, from which it is applied through connectors 2A4A3J1, 2A4P3, and 2A3J2 to the impedance matching networks in antenna coupler assembly 2A3 (para 1-32).

NOTE

Prefix all reference designators in this paragraph with operate alc circuit reference designator 2A4A3, unless otherwise specified.

b. The power on the 50 ohm line is sampled across capacitive divider C1, C2. This sampled voltage is detected by diode CR1, filtered by capacitor C3, and used to drive emitter follower Q1. The output from emitter follower Q1 is applied through connectors 2A4J2-A1, 2A1P2-A1, 2A1XA5-A3, 2A5J1-A3, feed-through capacitor 2A5A1C13, and pi-section

filter 2A5A1A2C8, 2A5A1A2L6, 2A5A1A2C6, to pin C of CONTROL connector 2A5J2 for connection to the receiver-transmitter (para 1-6 and 1-46). The output from emitter follower Q1 is also sampled across resistive divider R3, R6, and applied to pin 10 of connector 2A4J2, from which it is applied to TEST METER 2A5M1 (when TEST METER switch is set at POWER OUT) to provide a relative indication of the power output from the AM-3349/GRC-106 (para 1-44).

c. Resistor R1 provides a discharge path for capacitors C1 and C2. Resistor R2 provides a dc path to ground for detector CR1. Capacitors C4 and C5 are rf bypasses. Capacitor C6 is an audio bypass to remove all ac from the dc voltage applied to the TEST METER. Emitter follower Q1 is used to isolate the detector from the circuits in the receiver-transmitter.

1-42. Tune Automatic Level Control Signal Generation (fig. 4-52)

a. The input to power amplifier 2A1A1V1, 2A1A1V2 is detected and applied to the receiver-transmitter, when the TUNE OPERATE switch is set at TUNE. This voltage is used in addition to the operate alc signal to provide the additional control over the receiver-transmitter required for tuning.

NOTE

Prefix all reference designators in this paragraph with reference designator 2A1A1A1, unless otherwise noted.

b. The input to the grids of power amplifier 2A1A1V1, 2A2A2V2 is applied to a shunt detector circuit. When the signal goes positive capacitor C1 will charge to nearly the peak value of the applied signal through the low impedance of diode CR1. On the positive portion of the signal, diode CR1 will be reverse-biased, causing capacitor C1 to discharge through resistors R10 and R11 and thermistor RT1 (fig. 4-49). The discharge time constant is such that a modulated dc signal is applied to the base of emitter follower Q2. Emitter followers Q1 and Q2 are used to provide a high-impedance load for the shunt detector circuit and a low-impedance output to the receiver-transmitter. The output from emitter follower Q1 is applied through pin 25 of connectors 2A1XA5 and 2A5J1 and contacts 8 and 4 of

TUNE-OPERATE switch 2A5S6 (TUNE position) to pin B of CONTROL connector 2A5J2 for application to the receiver-transmitter (para 1-46).

c. Thermistor RT1 provides temperature compensation for the drive to emitter follower Q2. Capacitor C2 is an rf bypass Resistor 2A1A1R7 provides a dc return for the tune alc circuit.

1-43. Tuning of Antenna Coupler Assembly 2A3 (fig. 4-22)

NOTE

Prefix all reference designations used in *a* through *d* below with unit reference number 2.

a. *General.* When the interunit tuning cycle is completed (para 1-49), switches A2S4 and A2S5 will be positioned according to the MHz frequency setting for which the units are to be tuned. These switches provide coding information for programming the antenna coupler assembly for the frequency band in use. The chart in figure 4-22 provides a listing of the 30 tuning positions of these switches and their corresponding MHz passband. Whip coding switch A2S4 generates the coding information to position capacitor A3C27 and bandswitch A3S1 when a whip antenna is being used. The 50 ohm line coding switch, A2S5, generates the coding information to position capacitor A3C27 and bandswitch A3S1, when a doublet antenna (50 ohm line) is being used. As shown, the unit is tuned for position 1 (2.0 to 2.5 MHz). Assume that the operating frequency is changed (at the receiver-transmitter), to 26.xxx MHz. The interunit tuning will be accomplished and will set switches A2S4 and A2S5 at 13. These switches will then function to program the antenna coupler assembly for this new frequency. The programming provides the configuration according to the operating frequency as shown on figure 1-10. The following subparagraphs provide a detailed description of the programming necessary to obtain the configuration for the operating frequency for various types of antennas.

b. *Whip Antenna Programming.* When using a 15-foot whip antenna, whip coding switch A2S4 will program bandswitch A3S1 and capacitor A3C27. A detailed description of how this program is accomplished is given in (1) and (2) below.

(1) *Bandswitch A3S1 positioning.* When switch A5S5 connects WHIP connector A5J6 into the circuit, it mechanically positions microswitch A5S4. A ground from microswitch A2S4 is applied through pin 17 of connectors A5J1 and A1XA5 and pin 35 of connectors A1XA2 and A2J1 to the common contact of switch A5S4. This ground is applied through contact 13 (corresponding to position 13) of switch A2S4 to pin 9 of connector A2J1, which mates with pin 9 of connector A1XA2. A groundpath is then established through pin 3 of connectors A1XA3 and A3J1, feedthrough capacitor A3C1, contact 10 of switch A3S2, contact 4 of switch A3S2, feedthrough capacitor A3C23, pin 23 of connectors A3J1 and A1XA3, and pin 2 of connectors A1A1XA7 and A7J1 to pin 3 of bandswitch motor relay A7K3. Since 27 volts dc is applied to pin 7 of bandswitch motor relay A7K3, bandswitch motor relay A7K3 will energize and apply 27 volts dc (para 1-47d(1)) through contacts 1 and 6 of relay A7K3, pin 3 of connectors A7J1 and A1A1XA7, pin 22 of connectors A1XA3 and A3J1, and feedthrough capacitor A3C22 to motor A3B2. Since the other side of motor A3B2 is grounded, it will rotate, turning rf bandswitch coding switch A3S2 and the cam of switch A3S1 until the notch of the wiper of switch A3S2 aligns with contact 10. This will then break the groundpath to pin 3 of bandswitch motor relay A7K3, causing it to de-energize. Ground will be connected (in place of 27 volts dc) to motor A3B2 through contacts 8 and 6 of bandswitch motor relay A7K3. Motor A3B2 is then dynamically braked. With the antenna connected to WHIP connector A5J6, the rf bandswitch coding will vary, depending on frequency.

(2) *Capacitor A3C27 positioning.* Assuming that the interunit tuning has placed switch A2S4 at position 13 (*a* above), there would be no groundpath. Using another example, such as position 12 (19.xxx MHz), a groundpath will be produced as follows: ground ((1) above) is connected from the common contact of switch A2S4 through contact 12 of switch A2S4 to pin 20 of connector A2J1, which mates with pin 20 of connector A1XA2. The ground is then connected through pin 13 of connectors A2XA3 and A3J1, feedthrough capacitor A3C12, and contact 9 of switch A3S3 to contact 20 of switch A3S3. Contact 20 of switch A3S3 connects the

ground through feedthrough capacitor A3C12, pin 12 of connectors A3J1 and A1XA3, and pin 9 of connectors A1A1XA7 and A7J1 to pin 3 of capacitor motor relay A7K2. Since 27 volts dc is connected to pin 7 of capacitor motor relay A7K2 will energize and apply 27 volts dc (para 1-47d(1)) through contacts 1 and 6 of relay A7K2, pin 1 of connectors A7J1 and A1A1XA7, pin 14 of connectors A1XA3 and A3J1, and feedthrough capacitor A3C14 to motor A3B1. Since the other side of motor A3B1 is grounded, it energizes and rotates switch A3S3 and capacitor A3C27. Capacitor A3C27 is only in the circuit, however, when bandswitch A3S1 is in position 6 (*d* below). When the wiper notch of switch A3S3 is aligned with contact 9, the groundpath is broken and capacitor motor relay A7K2 de-energizes. Motor A3B1 is then dynamically braked by a ground (instead of 27 volts dc) connected from contact 8 of capacitor motor relay A7K2 through contact 6, pin 1 of connectors A7J1 and A1A1XA7, pin 14 of connectors A1XA3 and A3J1, and feedthrough capacitor A3C14.

c. Doublet (50-Ohm Line) Antenna Positioning. When using a doublet antenna switch A3S2 will program bandswitch A3S1, and a 50-ohm line switch A2S5 will program capacitor A3C27. Subparagraphs (1) and (2) below provide a detailed description of how this programing is accomplished.

(1) *Bandswitch A3S1 positioning.* When the antenna is connected to 50 OHM LINE connector A5J5, the groundpath to switch A2S4 from switch A5S4 (*b*(1) above) is broken. A new groundpath is then applied from SWITCH A5S4 through pin 18 of connectors A1XA2 and A2J1, diode A2A31CR1, pin 27 of connectors A2J1 and A1XA2, pin 1 of connectors A1XA3 and A3J1, and feedthrough capacitor A3C1 to contact 14 of switch A3S2. The motor is energized as stated in *b*(1) above and turns switch A3S2 until the wiper notch is aligned with contact 14, breaking the groundpath. This setting of bandswitch A3S1 is then used for all frequencies.

(2) *Capacitor A3C27 positioning.* Assuming that the interunit tuning has positioned switch A2S5 to position 13 (*a* above) and that switch A5S4 is connected to 50 OHM LINE connector A5J5, the groundpath is as follows: a ground is connected from the common contact of switch A2S5 through contact 13, pin 30 of connectors A2J1 and A1XA2, pin 10 of

connectors A1XA3 and A3J1, and feed-through capacitor A3C10 to contact 7 of switch A3S3. Contact 20 of switch A3S3 then connects ground to pin 3 of capacitor motor relay A7K2, which energizes and in turn energizes motor A3B1 (*b*(1) above). Motor A3B1 rotates switch A3S3 and capacitor A3C27 until the wiper notch of switch A3S1 is aligned with contact 7, causing the ground-path to be broken. Capacitor motor relay A7K2 then deenergizes and motor A3B1 is dynamically braked (*b*(1) above).

d. Programed Configuration. The switching accomplished in *b* and *c* above results in the setting of bandswitch A3S1 and capacitor A3C27. Bandswitch A3S1 selects either a tap on inductor A3L2, the short (position 4), or capacitor A3C27, depending on the frequency and the antenna used. The cam is used to apply a short across inductor A3L2 at the various frequencies where it is not used. The setting of A3S1, A3L1, and A3C26 result in the proper rough tuning of the antenna to the AM-3349/GRC-106 for the desired operating frequencies. The AM-3349/GRC-106 is then fine-tuned, using the ANT. TUNE and ANT. LOAD controls (para 1-39 and 1-40). Figure 1-10 illustrates the band-switching configurations for the various operating frequencies of Radio Set AN/GRC-106(*).

1-44. Test Meter 2A5M1 (fig. 4-53)

NOTE

Unless otherwise specified, prefix all reference designations in this paragraph with front panel assembly designator 2A5.

a. General. TEST METER M1, in conjunction with TEST METER switch S2, permits monitoring of the critical circuit parameters of Amplifier, Radio Frequency AM-3349/GRC-106. Subparagraphs *b* through *h* below describe in detail the parameter to be monitored.

b. Primary Voltage. When the SERVICE SELECTOR switch on the receiver-transmitter, is set at any operate position (SSB NSK, AM, CW, FSK) and the AM-3349/GRC-106 PRIM. PWR. switch (A2CB1) is set at ON, the 27-volt dc primary power is applied to contact 4 of relay A2K1 from PRIM. POWER connector J7. Also at this time, ground is ap-

plied to pin 1 of relay A2K1 from pin N of CONTROL connector J2. Therefore, relay A2K1 energizes, and the 27 volts dc at contact 2 is applied through pin 5 of connectors J1 and 2A2XA5 and pin 6 of connectors 2A1A1XA7 and 2A7J1 to contacts X1 and A2 of time-delay relay 2A7K4. After 60 seconds, time-delay 2A7K4 applies the 27 volts dc through contacts A2 and A1 to pin 7 of operate relay 2A7K5, which energizes, due to the ground on pin 3 from pin P of CONTROL connector J2. At this time, the 27 volts dc is applied from contact A2 of time-delay relay 2A7K4, through contacts 1 and 6 of operate relay 2A7K5, pin 15 of connectors 2A7J1 and 2A1A1CX7, pin 24 of connectors 2A1XA5 and J1, and resistors A5R2 to contact 1 of TEST METER switch S2B. Therefore, when TEST METER switch S2 is set at PRIM. VOLT, TEST METER M1 and resistor A5R2 are connected across the 27-volt dc supply through contacts 1 and 10 of sections A and B of switch S2. Resistor A5R2 establishes the sensitivity for TEST METER M1 when measuring the 27-volt dc primary power.

c. Low-Voltage Power Supply. The 500-volt dc output from the dc-to-dc converter assembly (part of 2A5) is developed across voltage divider consisting of A4R1, A4R2, A4R3, and A4R5. When TEST METER switch S2 is set at LOW VOLT, the low-voltage output is sampled across resistor A4R5, and a proportional amount is connected to meter M1 through contacts 2 and 10 of TEST METER switch S2, sections A and B. Resistor A4R4 establishes the sensitivity for TEST METER M1 when measuring the 500-volt dc output.

d. High-Voltage Power Supply. The bleeder circuit for the 2,400 volts dc output from dc-to-dc converter assembly A2 consists of resistors A2R3 (sections A through D) which are connected between the output positive side of diode package A2CR6 and the return negative side of diode package A2CR6. When TEST METER switch S2 is set at HIGH VOLT, the high voltage output is sampled across resistor A2R3D, and this proportional amount is connected to TEST METER M1 through contacts 3 and 10 of TEST METER switch, sections A and B. Resistor A5R6 establishes the sensitivity for TEST METER M1 when measuring the 2,400-volt dc output.

e. Driver Tube 2A8V1 Plate Current. When TEST METER switch S2 is set at DRIVER CUR., TEST METER switch S2 connects

TEST METER M1 between the cathode of driver amplifier 2A8V1 and ground, through resistor 2A8A2R8 (fig. 4-16), pin 4 of connectors 2A8J1 and 2A1A1XA8, pin 27 of connectors 2A1XA5 and J1 and contacts 4 and 10 of sections A and B of TEST METER switch S2. The meter then provides an indication of the amount of self-bias developed across resistors 2A8A2R3 and 2A8A2R4, or the amount of plate current. Resistor 2A8A2R8 establishes the sensitivity for TEST METER M1 when measuring the plate current of driver tube 2A8V1.

f. Drive to Grids of Power Amplifier 2A1A1V1, 2A1A1V2. When TEST METER switch S2 is set at GRID DRIVE, TEST METER M1 is connected to the tune alc output from emitter follower 2A1A1A1Q1 through pin 25 of connectors 2A1XA5 and J1, resistor A5R5 and contacts 5 and 10 of TEST METER switch S2. This output is directly proportional to the grid drive applied to power amplifier 2A1A1V1, 2A1A1V2 (para 1-42). Resistor A5R5 establishes the sensitivity for TEST METER M1 when measuring the drive to the grids of power amplifier 2A1A1V1, 2A1A1V2.

g. Power Amplifier 2A1A1V1, 2A1A2V2 Plate Current. The return path for power amplifier 2A1A1V1, 2A1A2V2 plate current is through resistor A5R1 and the coil of overcur-

rent sensing relay A3K1 to the negative side of diode package A2CR6. When TEST METER switch S2 is set at PA. CUR., TEST METER M1 is connected across resistor A5R1. The voltage drop across resistor A5R1 is applied through resistor A5R3 and contacts 6 and 10 of TEST METER switch S2, sections A and B. Resistor A5R3 establishes the sensitivity of TEST METER M1 when measuring the plate current of power amplifier 2A1A1V1, 2A1A1V2. When setting the quiescent operating point for power amplifier 2A1A1V1, 2A1A1V2, pa. idle current switch S1 is depressed. This action parallels resistor A5R4 with resistor A5R3 to change the sensitivity of TEST METER M1.

h. Power Output From Power Amplifier 2A1A1V1, 2A1A1V2. The output from the operate alc circuit is sampled across resistors 2A4A3R3 and 2A4A3R6 (para 1-41). When TEST METER switch S3 is set at POWER OUT, the sampled output from voltage divider 2A4A3R3, 2A4A3R6 is connected through pin 10 of connectors 2A4J2 and A1P3, pin 32 of connectors 2A1ZA5 and J1, and across TEST METER M1 through contacts 7 and 10 of TEST METER switch S2. This voltage is directly proportional to the power output from the AM-3349/GRC-106.

Section XI. FUNCTIONAL DESCRIPTION OF INTERUNIT CIRCUIT

DETAILS

1-45. General

The interunit circuits of Radio Set AN/GRC-106(*) consist of the following: an automatic level control circuit to maintain the power output at the correct level, a primary power control circuit, a keying circuit, and an interunit tuning circuit. Paragraphs 1-46 through 1-49 explain these interunits circuits in detail.

1-46. Level Control Signal Circuits (fig. 4-23)

a. General. The level control signal circuits maintain the output from Amplifier, Radio Frequency AM-3349/GRC-106 at a nominal predetermined value (400 watts pep). Two level control signals are used for controlling the AM-3349/GRC-106 output. They are the operate level control signal and the tune level control signal.

NOTE

Prefix all receiver-transmitter, reference designations in *b* and *c* below with unit number 1 and all the AM-3349/GRC-106 reference designations with unit number 2.

b. Operate Level Control Signal. When AM-3349/GRC-106 TUNE-OPERATE switch A5S6 is set at OPERATE, the tune level control signal output line is grounded through contacts 7 and C4. The output from the AM-3349/GRC-106 is sampled at the 50 ohm line, after load discriminator A4A2, and envelope-detected by diode A4A3CR1. The resulting modulated dc output signals are applied to emitter follower A4A3Q1, which is used to provide a low output impedance to minimize the loading of the receiver-transmitter. The output from emitter follower A4A3Q1 is ap-

plied through pin A1 of connectors A4J2 and A1P2, pin A3 of connectors A1XA5 and A5J1, feedthrough capacitor A5A1C13, and pi-section filter A5A4A2C8, A5A1A2L6, A5A1A2C6 to pin C of CONTROL connector A5J2, which is connected to pin C of PA CONTROL connector A1J20 on the receiver-transmitter through Cable Assembly, Special Purpose, Electrical CX-10099/U. Pin C of PA CONTROL connector J20 applies the level control signal through L-section filter A1A3C2, A1A3L2 and feedthrough capacitor A1C25 to ppc control A1R15 and apc control A1R14. Ppc control A1R15 is used to adjust the peak power control dc voltage level applied from the AM-3349/GRC-106 to ppc dc amplifier A3Q4 in transmitter IF and audio module 1A5 (para 1-6g). Apc control A1R14 is used to vary the dc voltage level applied to voltage divider A1R11, A1R5, and A1R6. The mode of operations determines the point on the voltage divider that is to be connected to the SERVICE SELECTOR switch. The SERVICE SELECTOR switch connects the dc voltage from the voltage divider to apc dc amplifier A3Q1 in Transmitter IF and Audio module 1A5 through diode A1CR7 (para 1-6f).

c. Tune Level Control Signal. The tune level control signal provides the additional control of the AM-3349/GRC-106 output required during tuning. Capacitor A1A1A1C1 takes a sampling of the input to power amplifier A1A1V1, A1A1V2. The negative-going portions of this signal are shunted to ground through diode A1A1A1CR1. The positive portions of the signal are applied to voltage divider A1A1A1R10, R11, and RT1 (fig. 4-49). The rf in the signal across the voltage divider is bypassed to ground by capacitor A1A1A1C2. Thermistor A1A1A1RT1 is used for temperature compensation to maintain a relatively constant input to emitter follower A1A1A1Q2. The signal applied to the base of emitter follower A1A1A1Q2 is essentially an unfiltered dc signal, portional to the peak-power level of the signal applied to power amplifier A1A1V1, A1A1V2. The signal is applied to emitter followers A1A1A1Q2 and A1A1A1Q1 (para 1-42). The output from emitter follower A1A1A1Q1 is applied through pin 25 of connectors A1XA5 and A5J1, contacts 8 and C4 of TUNE-OPERATE switch A5S6 (when set at TUNE), feedthrough capacitor A5A1C10, and L-Section filter A5A1A2L3, A5A1A2C3,

to pin B of CONTROL connector A5J2. CONTROL connector A5J2 is connected through Cable Assembly, Special Purpose, Electrical CX-10099/U to PA CONTROL connector A1J20 on the receiver-transmitter. The dc signal is applied through L-section filter A1A3C3-A1A3L3, diode A1CR8, feedthrough capacitor A1C26, and tune level control A1R13 to pin 7 of chassis connector A1XA5. Tune level control A1R13 is used to adjust the level of the tune level control signal. Chassis connector A1XA5 connects the tune level control signal to apc dc amplifier A3Q1 in transmitter IF and audio module 1A5 (para 1-6f).

1-47. Power Control Circuits (fig. 4-24)

a. General. The following subparagraphs provide a detailed description of the sequential application of primary power and the control circuits involved.

NOTE

Prefix all receiver-transmitter, reference designations in the following subparagraphs with the unit reference number 1 and module reference number as indicated on figure 4-24. Prefix all Amplifier, Radio Frequency AM-3349/GRC-106 reference designations with the unit reference number 2 and assembly number as indicated on figure 4-24.

b. Initial Voltage Application. Twenty-seven volts dc primary voltage for the AM-3349/GRC-106 is applied to pins A and B of PRIM. POWER connector A5J7. When PRIM. PWR. circuit breaker A5A2CB1 is set at ON, the 27 volts dc is applied through polarity diode A5A2CR1 to pin 4 and contact 3 of standby relay A5A2K1. Relay A5A2K1 is not energized until a ground is applied to pin 1. This prevents 27 volts dc from being applied to the AM-3349/GRC-106 circuits until this ground is present. The ground necessary for energizing relay A5A2K1 is generated by the SERVICE SELECTOR switch on the receiver-transmitter. When the SERVICE SELECTOR switch on the receiver-transmitter is set at STAND BY or any operate (CW, AM, FSK, or SSB NSK) position, section 2, front, connects a ground through feedthrough capacitor A1C24 and L-section filter A1A4L1, A1A4C1 to pin N of PA CONTROL connect-

or A1J20, which is connected to pin N of CONTROL connector A5J2 through Cable Assembly, Special Purpose, Electrical CX-10099/U. Pin N of CONTROL connector A5J2 connects the ground through L-section filter A5A1A2C7, A5A1A2L7, feedthrough capacitor A5A1C14, pin 21 of connectors A5J1 and A1XA5, pin 8 of connectors A1J1 and A6XA1, pin 8 of connectors A6J1 and A6A1P1, pin 7 of connectors A6P1 and A6J1, pin 7 of connectors A6XA1 and A1J1, pin 19 of connectors A1XA5 and A5J1, and thermostat A5S3, which will be closed at this time, to pin 1 of relay A5A2K1. If the equipment is overheated, A5S3 will open, deenergizing relay A5A2K1 and removing the 27 volts dc.

c. Standby Voltage Distribution. When ground is applied to pin 1 of relay A5A2K1, with the 27 volts dc on pin 4 (*b* above), relay A5A2K1 will energize and apply the 27 volts dc through contacts 3 and 2 to the following points: pins 3, 4, and 5 of connector A5J1, contact 4 of relay A5A2K, voltage regulator A5A3VR1, collector of switch A5A6Q1, contact C6 of TUNE-OPERATE switch S6, and to pin 3 of relay A5A3K2. Also at this time, 27 volts dc is applied from contact 3 of relay A5A2K1 to terminal 2 of transformer A5A2T1.

(1) From pins 3 and 4 of connector A5J1, the 27 volts dc is applied through pins 3 and 4 of connector A1XA5, pins 3 and 4 of connectors A1J1 and A6XA1, pins 3 and 4 of connectors A6J1 and A6P1, and part of the primary of transformer A6A1T1 to the collectors of switches A6A1Q1 and A6A1Q2. It is also applied through resistor A6A1R1 and part of the primary of transformer A6A1T1 to the bases of switches A6A1Q1 and A6A1Q2. These two applications start the switching action in the dc-to-dc inverter assembly (para 1-34).

(2) From pin 5 of connector A5J1, the 27 volts dc is applied through pin 5 of connector A1XA5 to the following points: power amplifier A1A1V1, A1A1V2 filaments, collectors of emitter followers A1A1A1Q1 and A1A1A1Q2, pin 3 of connector A1A1XA8, and pin 6 of connector A1A1XA7 (*d* below).

(a) The 27 volts dc is the filament voltage for power amplifier A1A1V1, A1A1V2. It is applied to pin 7 of A1A1V1 and to pin 3 of A1A1V2. Capacitors A1A1C16 and A1A1C17 provide filtering.

(b) The 27 volts dc is applied to emitter followers A1A1A1Q1 and A1A1A1Q2 to be used as operating voltage. These emitter followers are the output circuit for the tune level control signal (para 1-46c) and the TEST METER grid drive indication.

(c) The 27 volts dc at pin 3 of connector A1A1XA8 is applied through pin 3 of connector A8J1 and resistors A8A1R7, A8A1R5, and A8A1R6 to grid circuit of driver amplifier A8V1. This is the grid bias for driver amplifier A8V1, which is regulated by Zener diode A8A1VR1 and adjusted by A8A1R6.

(3) The 27 volts dc applied to resistor A5A3R2 in the regulator A5A3VR1 circuit (contact C6 of TUNE-OPERATE switch S6, pin 3 of relay A5A3K2, and the collector of A5A7Q1) is used as operating voltage for the dc-to-dc converter assembly protection circuits. For a detailed description of the operation of these circuits, refer to paragraphs 1-36 and 1-37.

d. Operate Voltage Distribution. The 27 volt standby supply is used to develop the 27 volt operate supply and is used in conjunction with it throughout the equipment as described below.

(1) The standby 27 volts dc at pin 6 of Connector A1A1XA7 is applied through pin 6 of connector A7J1 to contacts X1 and A2 of time-delay relay A7K4, contact 1 of operate relay A7K5, contact 1 of turret motor relay A7K1, pin 7 of tune locking relay A7K6, contact 1 of capacitor motor relay A7K2, and contact 1 of bandswitch motor relay A7K3. After a 60-second delay, contact A2 of time-delay relay A7K4 will close with contact A1, and the 27 volts dc is applied to pin 7 of operate relay A7K5. In any operate position (AM, FSK, CW SSB NSK), SERVICE SELECTOR switch A1S4 section 2, front, on the receiver-transmitter applies a ground through contacts 9 and 10, feedthrough capacitor A1C23, L-section filter A1A4L2, A1A4C2, pin P of filter A1A4L2, A1A4C2, pin P of PA CONTROL connector, Cable Assembly, Special Purpose, Electrical CX-10099/U, pin P of CONTROL connector A5J2, L-section filter A5A1A2C4, A5A1A2L4, feedthrough capacitor A5A1C11, pin 15 of connectors A5J1 and A1XA5, and pin 10 of connectors A1A1XA7 and A7J1 to pin 3 of relay A7K5. Therefore, as soon as the time delay is over, relay A7K5 is energized, the standby 27 volts dc at contact 1 is applied through contact 6 to pin 15 of connectors A7J1 and

A1A1XA7, contacts 2 and 4 of relay A7K6, and pin 11 of connectors A1XA5 and A5J1 to pin 7 of relay A5A2K2 and pin 1 of relay A5K1 to be used as the operate 27 volts dc. Anytime ground is applied to pin 3 of relay A7K6 (para 1-16), with 27 volts dc on pin 7, the relay will be energized, breaking the operate 27-volt line during tuning. When turret motor relay A7K1 is energized (para 1-49), the 27 volts dc at contact 1 is applied through contact 6, pin 4 of connectors A7J1 and A1A1XA7, and pin 1 of connectors A1XA2 and A2J1 to energize turret motor A2B1. When capacitor motor relay A7K2 is energized (para 1-43) the 27 volts dc at contact 1 is applied through contact 6, pin 1 of connectors A7J1 and A1S1XA7, pin 14 of A1XA3 and A3J1, and feedthrough capacitor A3C14 to energize capacitor coding motor A3B1. When bandswitch motor relay A7K3 is energized (para 1-43), the 27 volts dc at contact 1 is applied through contact 5, pin 3 of connectors A7J1 and A1A1XA7, pin 22 of connectors A1XA3 and A3J1, and feedthrough capacitor A3C22 to energize bandswitch motor A3B2.

(2) When the equipment is in standby, 27 volts dc is applied through contacts 4 and 2 of relay A5A2K2 to charge up capacitor A5A6C1. At the same time, 27 volts dc is applied to the collector of switch A5A6Q1. As long as the equipment is unkeyed, this condition remains static. When the equipment is in an operating condition, 27 volts dc is applied from pin 11 of connectors A1XA5 and A5J1 ((1) above) to pin 1 of relay A5K1 and pin 7 of relay A5A2K2. When the equipment is keyed (para 1-48a), ground is applied to pin 2 of relay A5K1, which will be energized to connect the rf output line to the antenna in use. This ground is also applied through contacts 5 and 1 of relay A5A3K3 to pin 3 of relay A5A2K2. When relay A5A2K2 is energized, capacitor A5A6C1 will discharge through contacts 5 and 2 to the base of switch A5A6Q1. Switch A5A6Q1 is driven into saturation, and the pulse is applied to the base of A5A2Q2 in the dc-to-dc converter assembly. Since 27 volts dc is available from pin 3 of transformer A5A2T1, A5A2Q2 will start the dc-to-dc converter switching action (para 1-35).

(3) The operate 27 volts dc applied to dropping resistor A5A5R2 is applied to pin 1 of TEST METER switch A5S2. When TEST

METER switch A5S2 is set at PRIM. VOLT, the 27 volts dc is applied to TEST METER M1 to provide an indication of the level of the operate 27 volts dc.

1-48. Keying Circuits (fig. 4-25)

NOTE

Prefix all receiver-transmitter, reference designations with unit reference number 1 and all Amplifier, Radio Frequency AM-3349/GRC-106 reference designations with unit reference number 2.

a. Keying Function Initiation. When the receiver-transmitter is keyed, a ground is placed on the keyline. This turns on transmit-recvie switch A5A1Q11, which turns on transmit-receive switch A5Q1 in transmitter IF and audio module 1A5. With transmit-receive switch A5Q1 conducting, tr line 3 is grounded. This ground is applied through pin 32 of connectors A5J1 and A1XA5, feedthrough capacitor A1C29, and L-section filter A1A4L6, A1A4C6 to pin T of PA CONTROL connector A1J20. PA CONTROL connector A1J20 connected to CONTROL connector A5J2 on the AM-3349/GRC-106 front panel. From pin T of CONTROL connector A5J2, the ground is applied through pi-section filter A1A1C6, A1A1AL6, A1A1C8, feedthrough capacitor A1C6, diode A5CR1, and contacts 5 and 1 of relay A5A3K3 to pin 3 of relay A5A2K2. With the receiver-transmitter SERVICE SELECTOR switch set at any operate position (SSB NSK, AM, CW, or FSK), the operate 27 volts dc is applied to pin 1 of relay A5K1 and to pin 7 of A5A2K2 (para 1-47d). Relay A5K1 will be energized and connect the RF line to the antenna in use and disconnect RCVR. ANT. connector A5J4. Relay A5A2K2 is energized and triggers dc-to-dc converter assembly A5A2 and completes the feedback path for the assembly (para 1-35).

b. Tune Locking Interlock. If a frequency change is made at the receiver-transmitter, the detents of switches A1S7, rear, A1S6, section 1, rear or A1S5, rear, connect a momentary ground from contact 7 to 8, contact 7 to 4, or contact 4 to 5, respectively. The momentary ground is applied through feedthrough capacitor A1C30 and L-section filter A1A3L4, A1A3C4 to pin H of PA CONTROL connector A1J20. Pin H of PA CONTROL connector A1J20 is connected to pin H of CONTROL

connector A5J2 on the AM-3349/GRC-106. Pin H of CONTROL connector A5J2 applies this momentary ground through L-section filter A1A2C5, A1A2L5, feedthrough capacitor A1C12, pin 20 of connectors A5J1 and A1XA5, pins 36 and 29 of connectors A1XA2 and A2J1, and pin 11 of connectors A1A1XA7 and A7J1 to pin 3 of tune locking relay A7K6 (para 1-47d), which energizes and locks itself through contacts 1 and 6. The ground contact 2 of operate relay A7K5 (para 1-47d) is applied through contact 5, pin 7 of connectors A7J1 and A1A1XA7, pin 13 of connectors A1XA5 and A5J1, contacts C1 and 1 of TUNE-OPERATE switch A5S6, pin 23 of connectors A5J1 and A1X5 and pin 12 of connectors A1A1XA7 and A7J1 to contact 1 of tune locking relay A7K6. When tune locking relay A7K6 energizes, the connection between contacts 2 and 4 is broken. This breaks the 27-volt operate line, deenergizing relays A5K1 and A5A2K2 (*a* above). Tune locking relay A7K6 will not deenergize until TUNE-OPERATE switch A5S6 is set at TUNE, breaking the self-locking groundpath. This serves as a reminder to the operator that the tuning must be rechecked and the ANT. TUNE and ANT. LOAD controls on the AM-3349/GRC-106 must be readjusted before reoperating the unit.

c. Turret Position Interlock. If the AM-3349/GRC-106 turret assembly is not positioned correctly, switch A2S1 will connect a ground through pin 29 of connectors A2J1 and A1XA2 and pin 11 of connectors A1A1XA7 and A7J1 to pin 3 of tune locking relay A7K6. As a result, tune locking relay A7K6 will be energized, and the process described in *b* above will be repeated.

d. Tune Information. When the TUNE-OPERATE switch is set at TUNE, the ground at contact 2 of operate relay A7K5 is applied through contact 5, pin 7 of connector A7J1 and A1A1XA7, pin 13 of connectors A1XA5 and A5J1, contacts C1 and 2 of TUNE-OPERATE switch A5S6, and diode A5CR2, causing relays A5K1 and A5A2K2 to be energized if the tuning cycle is completed and no overcurrent or undervoltage condition exists. This ground is also connected through feedthrough capacitor A1C7 and L-section filter A1A1L7, A1A1C7 to pin M of CONTROL connector A5J2. CONTROL connector A5J2 is connected to PA CONTROL connector J20 on the receiver-

transmitter. Pin M of PA CONTROL connector A1J20 applies this ground through L-section filter A1A4C7, A1A4L7, and feedthrough capacitor A1C2B to pin 10 of connector A1XA5 and pin 13 of connector A1XA7. Pin 10 of connector A1XA5 mates with pin 10 of connector J1 of transmitter IF and audio module 1A5. Pin 13 of connector A1XA7 mates with pin 13 of connector J1 on Receiver IF module 1A7. This ground is used in transmitter IF and audio module 1A5 for carrier reinsertion and changing the apc level (para 1-6). It is used in receiver IF module 1A7 for turning off the balanced modulator (para 1-12).

e. Antenna Coupler Interlock. If the AM-3349/GRC-106 antenna coupler is not positioned properly, or is in the process of positioning, the tune locking relay A7K6 is kept energized. The grounds applied to cap. motor relay A7K2, pin 3, and bandswitch motor relay A7K3, pin 3, are also applied through diodes A7CR7 and A7CR8 to pin 3 of tune locking relay A7K6. This action insures that tune locking relay A7K6 is energized, disabling the dc-to-dc converter, while the antenna coupler is positioning.

1-49. Tuning Circuits (fig. 4-26)

NOTE

Prefix all receiver-transmitter, reference designations in this paragraph with unit number 1 and all Amplifier, Radio Frequency AM-3349/GRC-106 reference designations with unit number 2.

a. The interunit tuning circuit is an open-seeking circuit that employs a five-wire coding scheme. Switches A1S5, A1S6, and A1S7 in the receiver-transmitter establish the code for 28-position switch A1S9 (para 1-23d) and simultaneously generates the five-wire code for positioning the turret in the AM-3349/GRC-106. Switches A1S5, A1S6, and A1S7 in the receiver-transmitter are analogous to a 30-position master (top switch) and its 30-position image (bottom switch) as shown in figure 4-26. Switches A1S5, A1S6, and A1S7 generate 1 of 30 series of opens and grounds. Each series represents 1 of the 30 tuning positions of the AM-3349/GRC-106 (*d* below). The master portion of switches A1S5, A1S6, and A1S7 applies the ground (or grounds) to master switch A2S2 in the AM-3349/GRC-106. This estab-

lishes a groundpath to turret motor relay A7K1 to energize it when 27 volts dc is available (*b* below). This causes motor B1 to energize and rotate switches A2S3 and A2S2 until the complement of the code on the master portion of A1S5, A1S6, and A1S7 appears on master switch A2S2. When master switch A2S2 reaches the position representing the complement of the code generated by the master portion of switches A1S5, A1S6, and A1S7, the groundpath to turret motor relay A7K1 will be broken. Turret motor relay A7K1 will then be deenergized and will dynamically brake motor B1. The image switches have the complementary code of their respective masters. These image switches are necessary only when a ground is removed from the code to which the units are already tuned. For example, the switches as shown in figure 4-26 represent a frequency selection of 2 to 2.5 MHz and a code of 0.1010. If it were desired to tune the units for 2.5 to 3 MHz, the code would be 01000 (*d* below). In this case, the number of grounds is reduced and it is necessary to use the image switches to establish the groundpath (*c* below). The code between the units employs a system of filters and feedthrough capacitors to provide the necessary rf isolation between the two units.

b. Assume that the receiver-transmitter frequency controls are set at 2.5xxx MHz. This means that the master and image portions of switches A1S5, A1S6, and A1S7 are eight positions clockwise from the position shown in figure 4-26. The master portions of switches A1S5, A1S6 and A1S7 then generate a code of 01000 (*d* below). This new code has ground present only on code line 2. Code line 2 at master switch A2S2 is open, which means there must be a path through the image switches. The ground is connected from code line 2 of the master portions of switches A1S5, A1S6, and A1S7 to code line 2 of image switch A2S3. Code line 2 of image switch A2S3 connects this ground to the image portions of switches A1S5, A1S6, and A1S7 through code line 4. Remembering that the image portion of switches A1S5, A1S6, and A1S7 is eight positions clockwise from that shown in figure 4-26, code lines 1, 3, 4, and 5 are all connected together. This means that ground is connected to code lines 1, 3, and 5 of master switch A3S2 and establishes the necessary groundpath for energizing turret motor relay A7K1 (*b* above). Motor B1 will then rotate switches A2S2 and

A2S3 eight positions counterclockwise, at which time, the complement codes will be present on master switch A2S2 and image switch A2S3. This will break the groundpath and deenergize turret motor relay A7K1.

c. Assume that the receiver-transmitter frequency controls are set at 14.xxx MHz. This causes the master and image portion of switches A1S5, A1S6, and A1S7 to be rotated two positions clockwise (*d* below). The master portions of switches A1S5, A1S6, and A1S7 then generate a code of 10010. This new code places a ground on code lines 1 and 4 of the master portions of switches A1S5, A1S6, and A1S7. At master switch A2S2, code line 4 is open, but code line 1 is closed; therefore, the ground is connected to the common contact of switch A2S2. The common contact establishes the groundpath to pin 3 of turret motor relay A7K1 through pin 24 of connectors A2J1 and A1XA2 and pin 5 of connectors A1A1XA7 and A7J1. Since pin 7 of turret motor relay A7K1 already has 27 volts dc present, if the TUNE-OPERATE switch is set at TUNE (para 1-44), the relay will be energized and will apply 27 volts dc at motor B1. Motor B1 will then rotate switches A2S2 and A2S3 two positions counterclockwise. At this time, the complement of the initial code is present on switch A2S2, breaking the groundpath. Turret motor relay A7K1 will deenergize and apply a ground to motor B1, dynamically braking it.

d. The following chart (table 1-4) illustrates the turret position and code pattern generated for each frequency band in the receiver-transmitter.

Table 1-4. Turret position and Code Pattern for Each Frequency Band

Freq (MHz)	Code line					Turret position
	1	2	3	4	5	
2.0-2.5	**0	*1	0	1	0	1
3.0-3.5	0	0	1	0	1	2
14-15	1	0	0	0	0	3
15-16	1	1	0	0	1	4
24-25	0	1	1	0	0	5
25-26	0	0	1	1	0	6
16-17	0	0	0	1	2	7
17-18	1	0	0	0	1	8
2.5-3.0	0	1	0	0	0	9
3.5-4.0	0	0	1	0	0	10
18-19	0	0	0	1	0	11
19-20	0	0	0	0	1	12
26-27	1	0	0	0	0	13
27-28	1	1	0	0	0	14

See footnotes at end of table.

Table 1-4. Turret Position and Code Pattern for Each Frequency Band—Continued

Freq (MHz)	Code line					Turret position
	1	2	3	4	5	
28-29	1	1	1	0	0	15
29-30	1	1	1	1	0	16
20-21	0	1	1	1	1	17
21-22	1	0	1	1	1	18
22-23	1	1	0	1	1	19
23-24	0	1	1	0	1	20
4-5	1	0	1	1	0	21
5-6	0	1	0	1	1	22
8-9	1	0	1	0	1	23
9-10	1	1	0	1	0	24
6-7	1	1	1	0	1	25
7-8	0	1	1	1	0	26
12-13	0	0	1	1	1	27

Table 1-4. Turret Position and Code Pattern for Each Frequency Band—Continued

Freq (MHz)	Code line					Turret position
	1	2	3	4	5	
13-14	1	0	0	1	1	28
10-11	0	1	0	0	1	29
11-12	1	0	1	0	0	30

*1 Represents ground.
**0 Represents open.

1-50. Interconnecting Cables Between Components

Figure 1-12 provides the schematic diagrams of the cables used to interconnect the components of Radio Set AN/GRC-106(*).

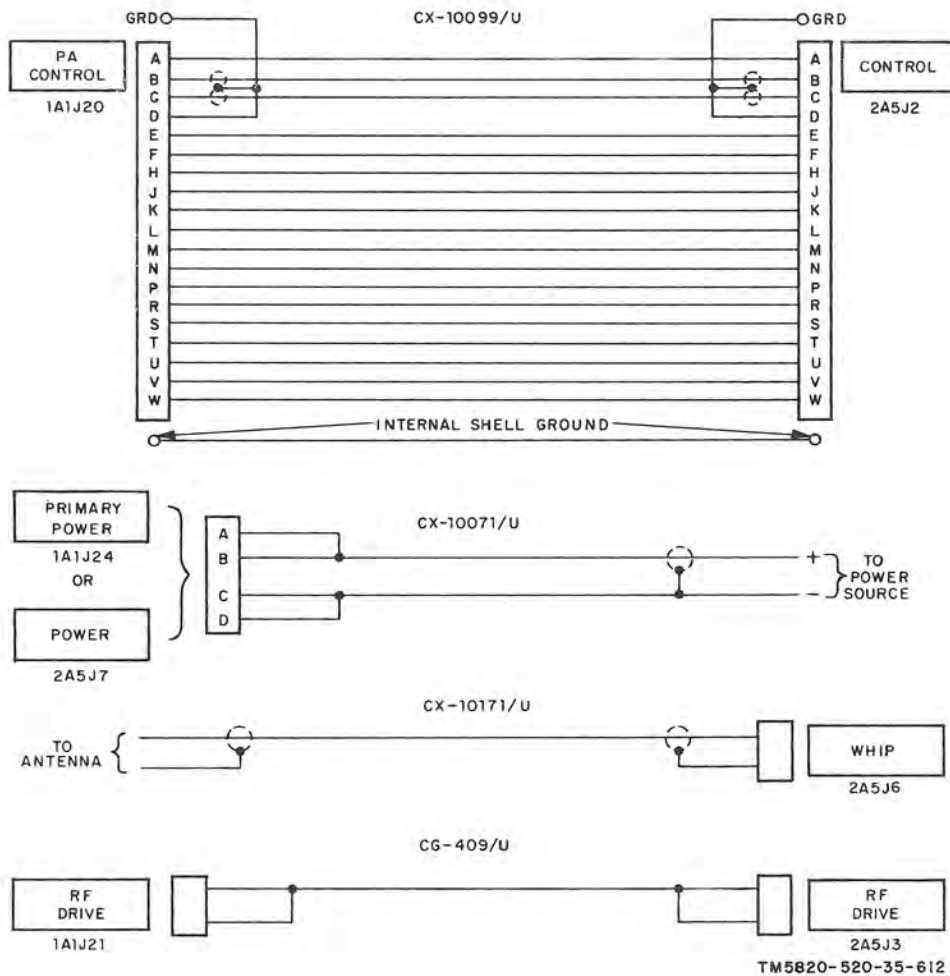

Figure 1-12. Interconnecting cables between components of Radio Set AN/GRC-106(*), schematic diagrams.

CHAPTER 2

DIRECT SUPPORT MAINTENANCE

Section I. INSTALLATION OF RADIO SET AN/GRC-106(*)

2-1. Tools Required for Installation

The tools required for installation must be selected according to the type of installation and the kind of vehicle to be used. Two 1/2 by 9/16-inch open-end wrenches (supplied) and a set of Allen wrenches will be required for any installation. Refer to TM 11-5820-520-12 for typical installation instructions; also, refer to SB 11-131 (Vehicular Radio Sets and Authorized Installations) for pertinent information.

2-2. Typical Installation of Radio Set AN/GRC-106(*)

a. The installation of the AN/GRC-106(*) (fig. 2-1) includes the attachment of the MT-3140/GRC-106 and Mast Base AB-652/GR (fig. 2-2) to the vehicle to be used. After selecting the appropriate installation unit (SE 11-131), position and attach these two items in accordance with the installation unit instructions. After the MT-3140/GRC-106 and AB-652/GR have been secured, install the AN/GRC-106(*) as outlined in *b* through *k* below.

b. Grasp one release handle in each hand; simultaneously pull the handles forward from their securing holes, and rotate them towards the outside of the mount. Place the heads of the adjusting screws on one crossbar assembly into the slots on one side of the MT-3140/GRC-106 with the flat side of the assembly toward the outside of the mount. Push the crossbar assembly fully into the slots. Adjust the 4 x 40 pan head screw in the opening of the slots so as to retain the crossbar assembly on the mount.

c. Repeat step in *b* above for other crossbar assembly.

d. Position the RT-662/GRC or the RT-834/GRC on the MT-3140/GRC-106 so that the feet on the bottom of the receiver-transmit-

ter set securely in the holes in the MT-3140/GRC-106.

e. Position the AM-3349/GRC-106 on top of the receiver-transmitter or on a separate MT-3140/GRC-106, depending on the type of installation. Set the feet on the bottom of the AM-3349/GRC-106 into the appropriate holes.

NOTE

For installations requiring side-by-side mounting of the units, two sets of shorter crossbar assemblies and another MT-3140/GRC-106 are required.

f. Position the crossbar assemblies so that they are resting against the sides of the unit. Using the 1/2 by 9/16-inch open-end wrench supplied with the mounting system, alternately tighten the two adjusting screws on each crossbar assembly until the respective crossbar is just touching the bottom of the mounting notch. Tighten each adjusting nut 1/4 turn. If necessary, tighten the Allen screws in each pivot assembly until a point of resistance is reached.

g. To insure that the tension on the crossbar assemblies is correct, grasp one release handle in each hand. Simultaneously pull the handles forward and rotate them toward the outside of the unit. Then rotate the handles back to the original horizontal position and push them back into the slots in the front of the MT-3140/GRC-106. If tension is correct, no binding will occur during this procedure, and the equipment will be secured on the MT-3140/GRC-106.

h. If the release handles cannot be rotated as described in *g* above, alternately loosen the two adjusting nuts on each crossbar until the step in *g* above can be performed properly.

i. If the equipment is not secured, alternately tighten the two adjusting nuts on each cross-

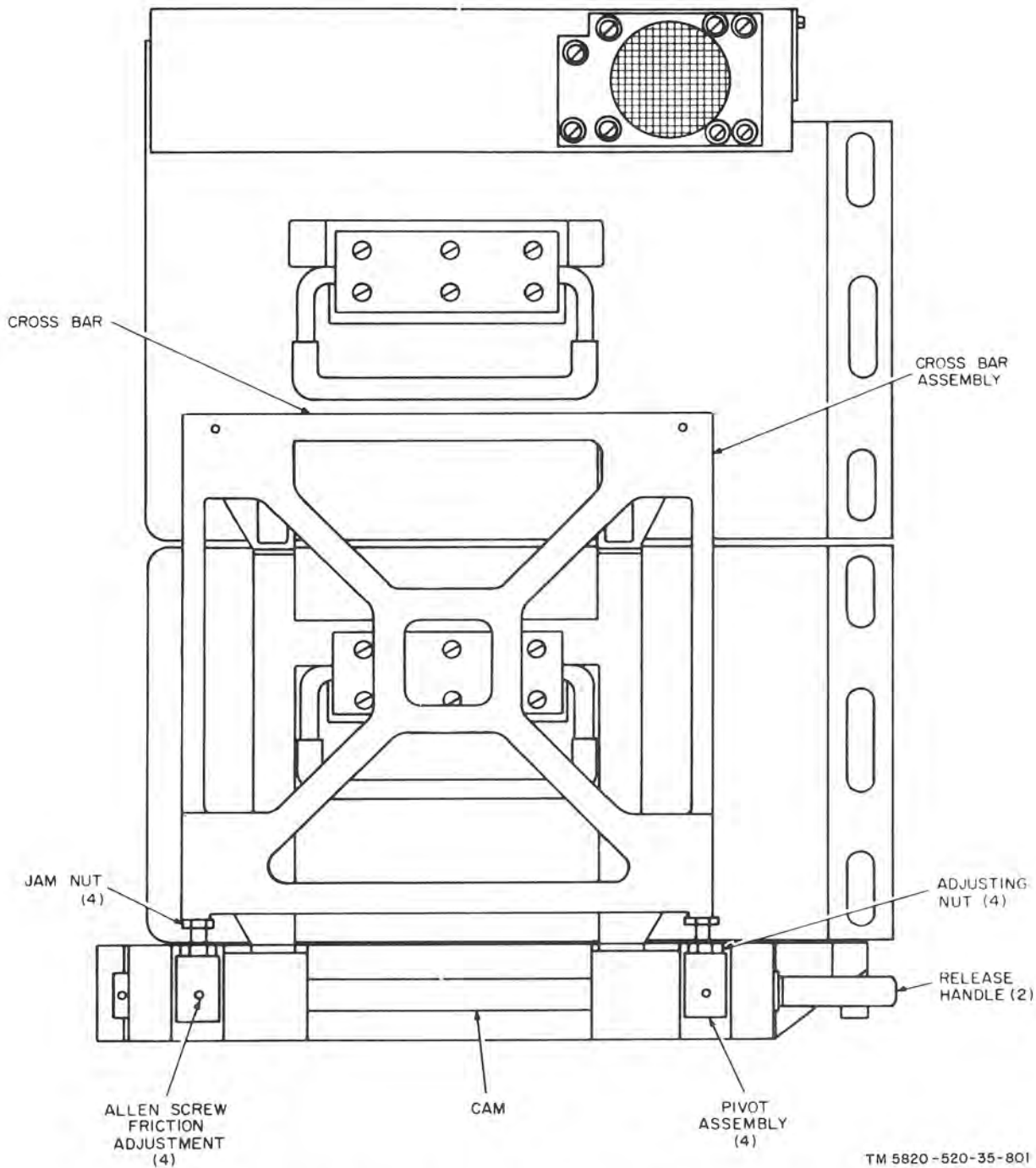

TM 5820-520-35-801

Figure 2-1. Radio Set AN/GRC-106(*) typical installation.

bar until the step in *g* above can be performed properly.

j. Pull the release handles forward and simultaneously rotate them towards the outside of the unit. If the friction is correct, the crossbar assemblies will move out from the case as the release handles are rotated. Enough friction should be present so that the crossbar assem-

blies and release handles remain where they are released. If the friction is not enough, adjust the Allen-head screw in each pivot assembly until sufficient friction is obtained.

CAUTION

Do not tighten the Allen-head screws so that the cam will not move within the pivot assembly.

k. After the friction has been checked and adjusted (*j* above), rotate the release handles simultaneously towards each other and push them into the respective slots in the front of the MT-3140/GRC-106.

2-3. Typical Interconnection (fig. 2-2)

a. Set AM-3349/GRC-106 PRIM. POWER switch and the receiver-transmitter SERVICE SELECTOR switch at OFF.

b. Install two Insulators PPL #3679 or equivalent in the tapped holes in the crossbar assembly. Thread Lead, Electrical CX-10171/U (6 feet) through the insulators. Cut the cable to length and attach in accordance with the installation unit instructions.

c. To assemble a 15-foot whip antenna, screw two Mast Sections MS-116-A together, screw Mast Section MS-117-A into one Mast Section MS-116-A, and screw Mast Section MS-118-A into Mast Section MS-117-A. Attach the remaining Mast Section MS-116-A to Mast Base AB-652/GR in accordance with the installation kit instructions.

d. Slide the antenna cover down over the MS-116-A attached to the AB-652/GR as far as it will go. Secure the cover in place with the brass antenna sheath clamp at the top of the

cover. Screw the assembled mast sections to the MS-116-A that is attached to the AB-652/GR.

e. To install Antenna Group AN/GRA-50 (doublet), refer to TM 11-5820-467-15.

f. To install the two Cable Assemblies, Special Purpose, Electrical CX-10071/U (10 feet), connect one each to the POWER and PRIM. POWER connectors on the RT-662/GRC or RT-834/GRC and AM-3349/GRC-106 front panels, respectively. Dress the two cables along the vehicle chassis in accordance with the installation unit instructions. Cut cables to length, solder the two terminal lugs, or power connectors to each (one on the positive center conductor and one on the negative braided loom shield), and attach the leads to the vehicle battery in accordance with installation unit instructions.

CAUTION

To avoid damage to transistors, proper polarity must be observed.

g. Connect all other cables in accordance with figure 2-2 and the installation unit instructions.

NOTE

Refer to figure 1-12 for the schematic diagrams of the cables used to interconnect the components of Radio Set AN/GRC-106(*).

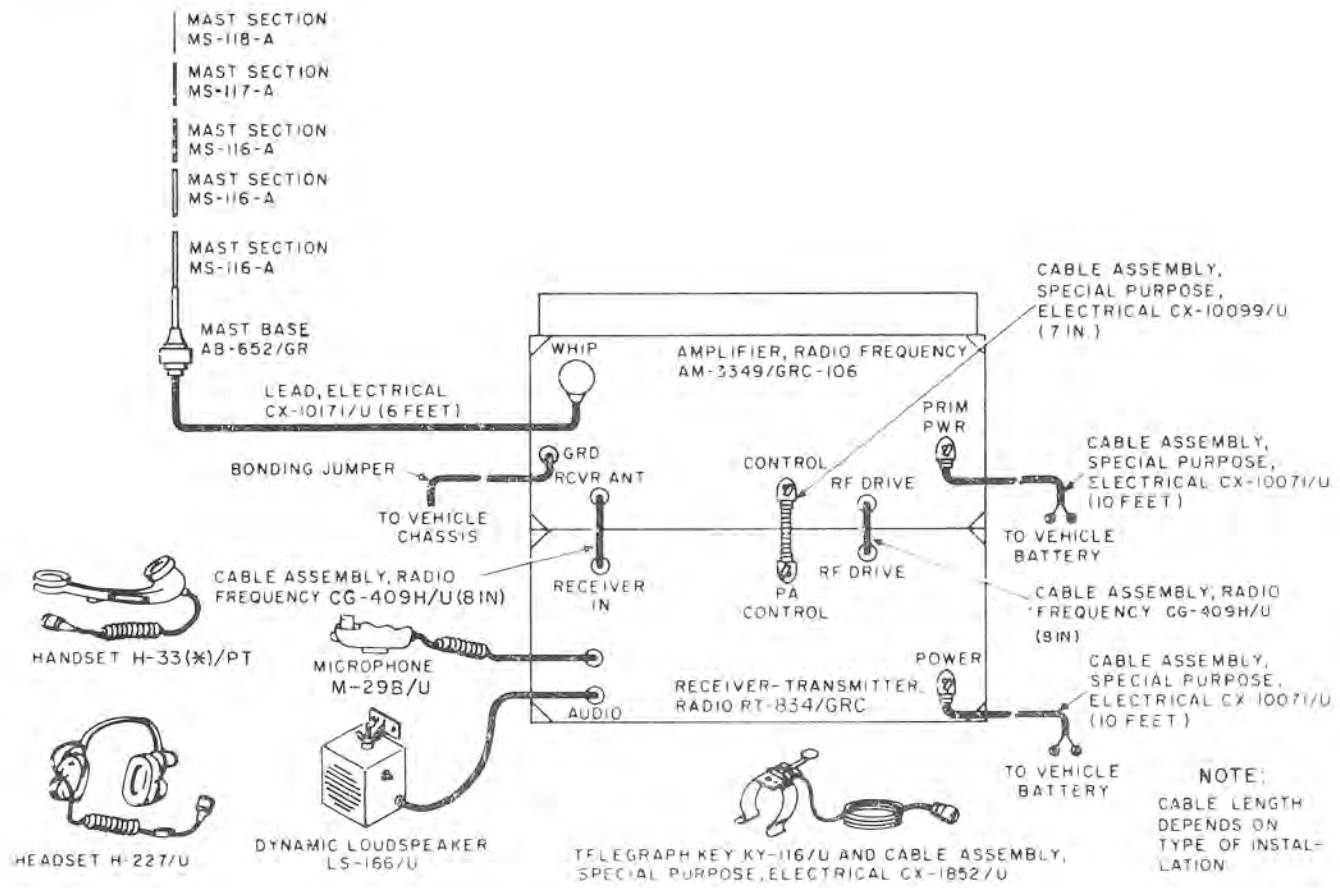

TM 5820-520-35-802

Figure 2-2. Radio Set AN/GRC-106(*) typical cording diagram.

Section II. TROUBLESHOOTING RADIO SET AN/GRC-106(*)

WARNING

When troubleshooting Radio Set AN/GRC-106(*), be extremely careful when working on or around the circuits of dc-to-dc converter (part of front panel assembly 2A5), antenna coupler assembly 2A3, and front panel assembly 2A5. Voltages as high as 3,000 volts dc and 10,000 volts rf exist in these assemblies. Wait 15 seconds after turning off power before shorting out any capacitors in the AM-3349/GRC to prevent damage to capacitor 2A5A2C6.

2-4. General Instructions

The direct support maintenance procedures given in this manual supplement the procedures described in the operator and organizational maintenance manual (TM 11-5820-520-12). The systematic troubleshooting procedure, which begins with the operational and sectionalization checks that can be performed at an organizational level, is carried to a higher level in this manual. Sectionalizing, localizing, and isolating techniques used in the troubleshooting, procedures are more advanced. Sections III, IV,

and V describe intraunit (within the unit) field maintenance localizing and isolating procedures.

2-5. Organization of Troubleshooting Procedures

a. *Reference Designations.* Receiver-Transmitter, Radio RT-662/GRC and RT-834/GRC module reference designations are prefixed with the numeral 1, and Amplifier, Radio Frequency AM-3349/GRC-106 assembly reference designations are prefixed with the numeral 2.

(1) The following is a list of the modules and assemblies in Receiver-Transmitter, Radio RT-662/GRC and RT-834/GRC:

- (a) Chassis and front panel assembly 1A1.
- (b) 100 Hz synthesizer 1A1A2A8, on RT-834/GRC only.
- (c) 100 kHz synthesizer module 1A2.
- (d) Frequency standard module 1A3.
- (e) 10 and 1 kHz synthesizer module 1A4.
- (f) Transmitter IF and audio module 1A5.
- (g) Frequency dividers module 1A6.
- (h) Receiver IF module 1A7.
- (i) Translator module 1A8.
- (j) MHz synthesizer module 1A9.
- (k) Receiver audio module 1A10.
- (l) Dc-to-dc converter and regulator module 1A11.
- (m) Rf amplifier module 1A12.

(2) The following is a list of the assemblies in Amplifier, Radio Frequency AM-3349/GRC-106:

- (a) Chassis assembly 2A1.
- (b) Turret assembly 2A2.
- (c) Antenna coupler assembly 2A3.
- (d) Discriminator assembly 2A4.
- (e) Front panel assembly 2A5.
- (f) Case assembly 2A6.
- (g) Relay assembly 2A7.
- (h) Driver assembly 2A8.
- (i) Stator assembly 2A9.

(3) An example of use of the reference designations is as follows: The full reference designation of a resistor is 2A5A6R3. The 2A5 indicates the AM-3349/GRC-106 front panel assembly (fig. 2-33); A6 is a printed board containing components and is located below A4 (B, fig. 2-33); R3 is a resistor located on printed board 2A5A6 (fig. 2-14). Resistor R3, by use of the full reference designation, can be found on figure 4-53.

b. General. The first step in servicing a defective Radio Set AN/GRC-106(*) is to sectionalize the fault, which means tracing the fault to a major component. The second step is to localize the fault, which means tracing the fault to a defective module, assembly, or stage. The final step is to isolate the fault to the defective stage or part within the module or assembly responsible for the abnormal condition. Some faults, such as burned-out resistors and shorted transformers, can often be located by

sight, smell, or hearing. The majority of faults, however, must be isolated by checking voltages, resistances, waveforms, and continuity.

c. Sectionalization. The interunit troubleshooting procedures in TM 11-5820-520-12 provide a group of tests arranged to reduce unnecessary work and to aid in tracing trouble in a defective AN/GRC-106(*). The first step is to locate the unit at fault by the following methods:

(1) *Visual inspection.* The purpose of visual inspection is to locate faults without testing or measuring the circuits. All visual signs should be observed and an attempt made to sectionalize the fault to a particular module, assembly, or stage.

(2) *Operational tests.* Operational tests frequently indicate the general location of a trouble. In many instances, the tests will help in determining the exact nature of the fault. Operational tests can be made by following the operating procedures in TM 11-5820-520-12.

d. Localization and Isolation. The tests listed below will aid in localizing and isolating the trouble. First localize the trouble to a module, assembly, or stage and then isolate the trouble within the module, assembly, or stage to a defective part. Use the following methods of trouble localization and isolation:

(1) *Troubleshooting chart.* The meter indications, or lack of meter indications, and operational checks provide a systematic method of localizing trouble to a module, assembly, or stage. The trouble symptoms listed in tables 2-4, 2-5, and 2-6 provide additional information for localizing trouble.

(2) *Voltage measurements.* The equipment is transistorized. When measuring voltages, use tape or sleeving (spaghetti) to insulate the entire test probe, except the extreme tip. A momentary short circuit can ruin a transistor.

(3) *Resistance measurements.* Make resistance measurements in this equipment only as directed on the voltage and resistance charts. Use the ohmmeter range specified on these charts; otherwise the indications obtained will be inaccurate.

CAUTION

Before using an ohmmeter to test transistors or transistor circuits, check the open circuit voltage across the ohmmeter test leads. Do not use an ohmmeter if the open-circuit voltage ex-

ceeds 1.5 volts. Also, since the RX1 range normally connects the ohmmeter internal battery directly across the test leads, the comparatively high current (50 ma or more) may damage the transistor under test. As a general rule do not use the RX1 range of an ohmmeter when testing low-power transistors.

(4) *Test points.* The modules of this equipment are equipped with test points to facilitate the connection of test equipment. The test points should be used whenever possible to avoid needless disassembly of equipment. Test points on the RT-662/GRC and RT-834/GRC are identified on the tops of the individual modules. Test points on the AM-3349/GRC-106 are identified on the referenced illustrations.

(5) *Intermittent troubles.* In all of the tests, the possibility of intermittent troubles should not be overlooked. If present, this type of trouble often may be made to appear by tapping or jarring the equipment. Make a visual inspection of the wiring and connections to the components of the radio set. Minute cracks in printed circuit boards can cause intermittent operation. A magnifying glass is often helpful in locating defects in printed circuit boards. Continuity measurements of printed conductors may be made by use of the same techniques used on hidden conventional wiring; observe ohmmeter precautions discusses in (3) above.

(6) *Resistor, capacitor, and inductor color code diagrams.* Resistor, capacitor, and inductor color code diagrams (fig. 4-20) are provided to aid maintenance personnel in determining the value, voltage rating, and tolerance of capacitors, inductors and resistors.

2-6. Test Equipment Required

Table 2-1 lists the test equipment required for troubleshooting Radio Set AN/GRC-106(*) and also lists the associated technical manuals.

Table 2-1. Equipment Required for Direct Support Troubleshooting

Test equipment	Technical manual
Voltmeter, Electronic AN/URM-145 with Adapter 91-8A	TM 11-6625-524-14
Multimeter ME-26(*)/U ^a	TM 11-6625-200-15
Oscilloscope AN/USM-281A	TM 11-6625-1703-15

Table 2-1. Equipment Required for Direct Support Troubleshooting—Continued.

Test equipment	Technical manual
Voltmeter, Electronic ME-30(*)/U ^b	TM 11-6625-320-12
Multimeter TS-352B/U	TM 11-6625-366-15
Power Supply PP-4763(*)/GRC ^c	TM 11-5820-765-12
Spectrum Analyzer TS-723(*)/U ^d	TM 11-5097
Dummy Load DA-75/U with male Type "N" connector	
Attenuator, Step CN-764/U	
Handset H-33(-)/PT ^e	TM 11-5965-202-35
Resistor 51 ohms, 1 watt	
Cable Assembly, Special Purpose, Electrical (W23) FSN 5995-832-6861	

^a Multimeter ME-26(*)/U includes ME-26A/U, ME-26B/U, ME-26C/U, and ME-26D/U.

^b Electronic Voltmeter ME-30(*)/U includes ME-30A/U, ME-30B/U, ME-30C/U, and ME-30E/U.

^c Power supply PP-4763(*)/GRC includes PP-4768/GRC and PP-4763A/GRC.

^d Spectrum Analyzer TS-723(*)/U includes TS-723A/U, TS-723B/U, TS-723C/U, and TS-723D/U.

^e Handset H-33(*)/PT includes H-33D/PT, H-33E/PT, and H-33F/PT.

CAUTION

1. This equipment contains transistor circuits. If the test equipment does not have an isolation transformer in its power supply circuit, connect one in its power input circuit. A suitable transformer is identified by FSN 5950-356-1779.
2. Never connect test equipment (other than multimeter and vacuum tube voltmeters (vtvms)) outputs directly to a transistor circuit; use a suitable coupling capacitor.
3. Be very careful when making test equipment connections so that shorts will not be caused by exposed test equipment connectors. Tape or sleeve (spaghetti) test prods or clips if necessary to leave as little exposed surface as needed to make contact to the circuit under test.

2-7. Test Point Information

Table 2-2 lists the test point information for the RT-662/GRC and RT-834/GRC. The waveform diagram (fig. 4-28) shows the wave shape to be expected and the conditions required for setting up the oscilloscope AN/

USM-281A. The test points given in figure 4-28 are alternate test points to be used by higher maintenance category personnel. Table 2-3

lists the test point information for the AM-3349/GRC-106. Figure 2-3 shows test points on rear of AM-3349/GRC-106.

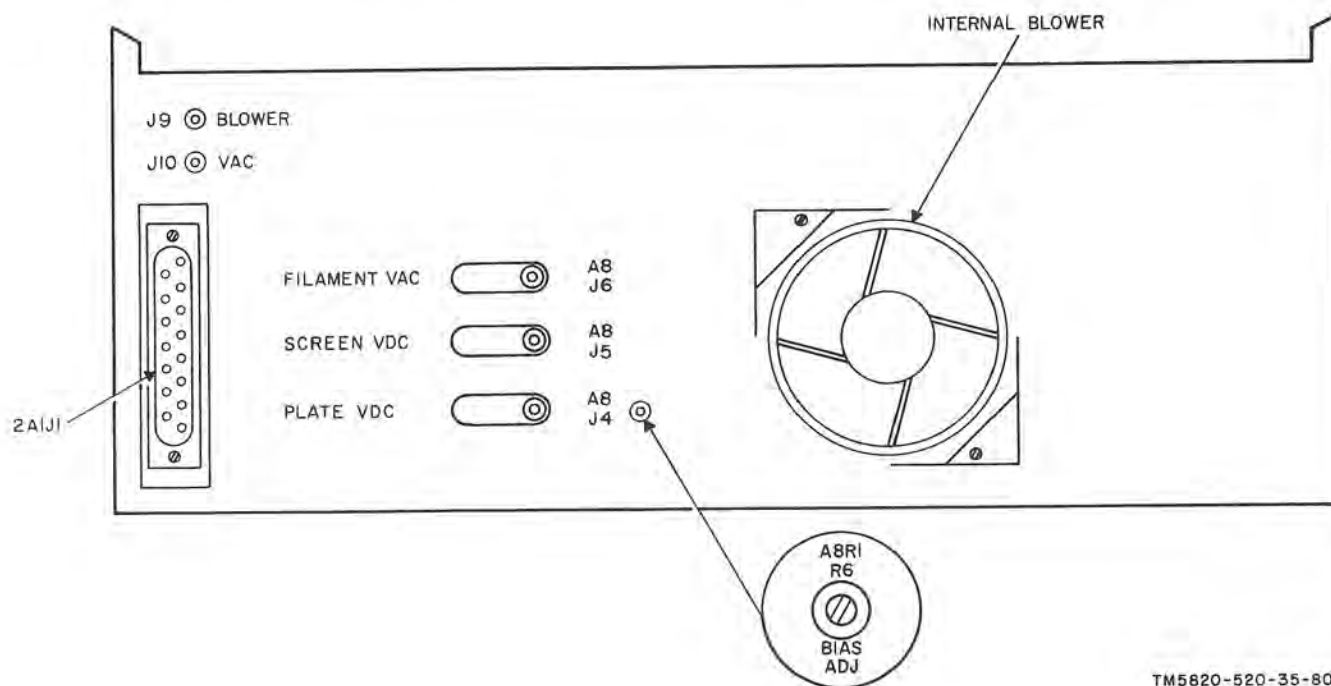

TM5820-520-35-803

Figure 2-3. AM-3349/GRC-106, rear chassis view, test point location.

Table 2-2. Receiver-Transmitter, Radio RT-662/GRC and RT-834/GRC, Test Point Information

Item No.	Module	Test point (fig. 2-26)	Indication	Test equipment
1	100 kHz Synthesizer 1A2.	100 kHz SYNTH OUP T (1A2A2J1).	Lo: 120 ±10 millivolts (mv) (22.4 to 23.3 MHz ±400 Hz). Hi: 145 ±15 mv (32.4 to 33.3 MHz ±400 Hz).	Voltmeter, Electronic AN/URM-145.
2	Frequency standard 1A3.	500 kHz OUP T (1A3A2J2).	220 ±30 mv (500 kHz ±0.05 Hz).	Voltmeter, Electronic AN/URM-145.
		1MHz OUP T (1A3A2J1).	550 ±80 mv (1 MHz ±0.1 Hz).	Voltmeter, Electronic AN/URM-145.
		10MHz OUP T (1A3A3J1).	50 ±15 mv (10 MHz ±1.0 Hz).	Voltmeter, Electronic AN/URM-145.
		5MHz INT/EXT (1A3A3J2).	110 ±20 mv (5 MHz ±0.5 Hz).	Voltmeter, Electronic AN/URM-145.
	FREQ STD connector (front panel).	-----	250 ±50 mv across 50 ohms (5 MHz ±0.5 Hz).	
3	10 and 1 kHz Synthesizer 1A4.	10 & 1 kHz SYNTH OUP T (1A4A1J1).	120 ±30 mv (4.551 to 4.650 MHz ±400 Hz).	Voltmeter, Electronic AN/URM-145.
		7.089MHz OUP T (1A4A2J1).	35 ±5 mv (7.089 MHz ±400 Hz). (7.089 MHz for RT-834/GRC, 7.1 MHz for RT-662/GRC).	Voltmeter, Electronic AN/URM-145.
4	Transmitter IF and audio 1A5.	XMTR AUDIO IN (1A5A2J1).	200 ±10 mv ^a -----	Voltmeter, Electronic ME-30(*)/U.
		APC (1A5A1J2)-----	0 to 3 volts dc-----	Multimeter ME-26(*)/U.
		PPC (1A5A1J5)-----	0 to 3 volts dc-----	Multimeter ME-26(*)/U.

See footnotes at end of table.

Table 2-2. Receiver-Transmitter, Radio RT-662/GRC and RT-834/GRC, Test Point Information—Continued

Item No.	Module	Test point (fig. 2-26)	Indication	Test equipment
5	Frequency dividers 1A6.	XMTR IF OUTPUT (1A5A1J3).	35 ± 5 mv ^a	Voltmeter, Electronic AN/URM-145.
		100kHz SPEC OUPT (1A6A1J1).	Spectrum: prr of 10 microseconds (μsec) and amplitude of 600 ± 150 mv peak to peak.	Oscilloscope AN/USM-281A (j and k, fig. 4-28).
		10kHz SPEC OUPT (1A6A2J1).	Spectrum: prr 100 μsec and amplitude of 110 ± 30 mv peak to peak.	Oscilloscope AN/USM-281A (p, q, r, s, fig. 4-28).
6	Receiver IF 1A7	1kHz PULSE OUPT (1A6A3J1).	Pulse: prr 1 ms and amplitude of 1.3 ± 0.3 volts peak.	Oscilloscope AN/USM-281A (t and u, fig. 4-28).
		SSB FILT OUTPUT (1A7A1J2).	Transmit: 1 ± 0.3 mv. Receive: 270 to 6,000 microvolts (uv). ^b	Voltmeter, Electronic AN/URM-145.
		IF AGC (1A7A2J1)	1.8 to 3.9 volts dc	Multimeter ME-26(*)/U.
7	Translator 1A8	RF AGC (1A7A2J2)	0 to -25 volts dc	Multimeter ME-26(*)/U.
		BAL MOD INPUT (1A7A4J2).	8.0 ± 25 mv audio, 0.5 to 2.0 mv-1.75 MHz. ^c	Voltmeter, Electronic AN/URM-145.
		RCVR OUPT (1A8A1J1).	12 ± 6 db ^d above level at RF OUTPUT test point on top of rf amplifier module 1A12.	Voltmeter, Electronic AN/URM-145.
8	MHz Synthesizer 1A9	XMTR OUTPUT (1A8A3J1).	8 ± 6 db ^e above level at XMTR IF OUTPUT test point on top of transmitter IF and audio module 1A5.	Multimeter ME-26(*)/U and Voltmeter, Electronic AN/URM-145.
		MHz SYNTH OUPT (1A9A3J1).	60 ± 20 mv (2.5 to 23.5 MHz ± 1 part in 10 ^f).	Voltmeter, Electronic AN/URM-145.
		DC LOCK VOLT (1A9A3J2).	8 to 17 volts dc	Multimeter ME-26(*)/U.
9	Receiver audio 1A10	10 MW OUPT (1A10J3).	2.0 to 3.0 volts ac ^g	Voltmeter, Electronic ME-30(*)/U.
		2 W OUPT (1A10J2)	30 to 40 volts ac ^g	Voltmeter, Electronic ME-30(*)/U.
10	Dc-to-dc converter and regulator 1A11.	20 VDC REG (1A11A1J1).	19.5 ± 0.5 volts dc	Multimeter ME-26(*)/U.
		6.3 VAC (1A11A2J1, J2).	13.0 ± 1.0 volts ac peak to peak (test point to test point).	Oscilloscope AN/USM-281A.
		-30 VDC (1A11A3J2)	-33.5 ± 2.0 volts dc	Multimeter ME-26(*)/U.
		+125 VDC (1A11A3J1)	127 ± 15 volts dc	Multimeter ME-26(*)/U.
11	Rf Amplifier 1A12	RF OUTPUT	45 ± 6 db above input level. ^h	Voltmeter, Electronic AN/URM-145.
		E1	19.5 ± 0.5 vdc	Multimeter ME-26(*)/U.
12	Internal ALC Assembly 1A1A5	E2	RF input at a level of 2.5 v rms.	Multimeter ME-26(*)/U.
		E3	Ground	Multimeter ME-26(*)/U.
		E4	Same as E2	Multimeter ME-26(*)/U.
		E5	Ground	Multimeter ME-26(*)/U.
		E6	Alc output at a level of 2.5 to 3.5 vdc.	Multimeter ME-26(*)/U.
		E7	Ground	Multimeter ME-26(*)/U.
		Q1—base	3.1 to 4.1 vdc	Multimeter ME-26(*)/U.
		Q1—emitter	-2.5 to -3.5 vdc	Multimeter ME-26(*)/U.
	Q1—collector	-19.5 vdc	Multimeter ME-26(*)/U.	

^a 200 mv, 1,000 Hz and 600 ohm AUDIO (pin J) input.

^b With rf inputs varied from 0.5 microvolts to 1.0 volt.

^c Audio input removed.

^d Approximately 30 mv must be present at the rf amplifier module 1A12, RF OUTPUT test point.

^e Cannot be measured directly. Set age/alc switch 1A1S11 (fig. 2-42) at off. Measure the gain of rf amplifier module 1A12 in the receive mode. Key the transmitter and measure the output at the XMTR IF OUTPUT test point on top of transmitter IF and audio module 1A5. Measure the level at the RF OUTPUT test point on top of rf amplifier module 1A12 in db above level at the XMTR IF OUTPUT test point. The difference in gain of rf amplifier module 1A12 in receive and gain at RF OUTPUT test point above the XMTR IF OUTPUT test point is the gain of translator module 1A8 in transmit.

^f AUDIO GAIN control maximum clockwise and modulated rf input.

^g Translator module 1A8 removed and a 50 ohm load connected at connector 1A1XAB-B-2.

Table 2-3. Amplifier, Radio Frequency AM-3349/GRC-106, Test Point Information

Item No.	Module	Test point	Indication	Test equipment	Figure
1	Chassis 2A1	BLOWER (2A1J10, J9)	141 volts ac $\pm 10\%$ (test point to test point).	Multimeter TS-352B/U	2-3
NOTE					
All measurements are made with 27 volts dc at the PRIM POWER connector, the RT-662/GRC or RT-834/GRC and AM-3349/GRC-106 completely interconnected, and with the TUNE-OPERATE switch set at TUNE.					
2	Plenum 2A1A1	V2 BIAS VDC (2A1A1J3)	-25 to -35 volts dc	Multimeter ME-26(*)/U	2-31
		BIAS SUPPLY VDC (2A1A1J4).	-110 ± 11 volts dc	Multimeter ME-26(*)/U	2-31
		RF GRID DRIVE (2A1A1J5).	Tune: 7 volts ac $\pm 5\%$ CW: 13 volts ac $\pm 5\%$ SSB two tone: 20 volts ac $\pm 5\%$.	Multimeter ME-26(*)/U	2-31
		V1 BIAS VDC (2A1A1J6)	-25 to -35 volts dc	Multimeter ME-26(*)/U	2-31
		SCREEN VDC (2A1A1J8)	400 ± 20 volts dc	Multimeter ME-26(*)/U	2-31
3	Front Panel 2A5 (p/o 2A1A1).	PRIM. V (2A1A1J8)	26.5 ± 0.5 volts dc	Multimeter ME-26(*)/U	2-31
		L.V. (2A1A1J9)	20 ± 2 volts dc	Multimeter ME-26(*)/U	2-31
		H.V. (2A1A1J10)	500 ± 30 volts dc	Multimeter ME-26(*)/U	2-31
4	Driver 2A8	PLATE VDC (2A8J4)	200 ± 10 volts dc	Multimeter ME-26(*)/U	2-3
		SCREEN VDC (2A8J5)	160 ± 8 volts dc	Multimeter ME-26(*)/U	2-3
		FILAMENT VAC (2A8J6)	7.0 volts ac $\pm 10\%$	Multimeter ME-26(*)/U	2-3

Section III. TROUBLESHOOTING RECEIVER-TRANSMITTER, RADIO

RT-662/GRC AND RT-834/GRC

CAUTION

Do not attempt removal or replacement of the modules or assemblies in the RT-662/GRC or RT-834/GRC without reading the procedures in section VI.

2-8. Test Setup (fig. 2-4)

a. General. Bench tests of the RT-662/GRC or RT-834/GRC require connection to a power source and to various test equipments. The power source must be connected to the RT-662/GRC or RT-834/GRC for all dynamic servicing procedures; the test equipment connections vary from test to test. Remove the RT-662/GRC or RT-834/GRC from its case by loosening the six captive Allen screws and sliding out the chassis. Remove and store the 13 screws and washers that secure the RT-662/GRC or RT-834/GRC bottom cover plate.

b. Power Supply Connections. Connect the PP-4763/GRC to the POWER connector on the RT-662/GRC or RT-834/GRC; use Cable Assembly, Special Purpose, Electrical CX-10071/U. Check for the correct voltage at the primary source voltage, and the PP-4763/GRC output voltage.

c. Preliminary Test. Prior to connecting the RECEIVER IN and FREQ STD connectors, perform the following test:

- (1) Set the SERVICE SELECTOR switch at SSB/NSK and allow a 15-minute warmup.
- (2) Connect the AN/URM-145 with adapter 91-8A to the FREQ STD connector and check for the presence of a 250 ± 50 mv level. If the indication is not correct, proceed to item 1 of table 2-4 (para 2-9d).

d. Test Equipment. Connect the H-33(*)/PT to the AUDIO connector on the RT-662/GRC or RT-834/GRC. Connect the test equipment (fig. 2-4) as called out in the particular tests (para 2-9d). Set the frequency controls at 04998, the SQUELCH switch at OFF, the FREQ VERNIER control at OFF, and the MANUAL RF GAIN control maximum clockwise, unless otherwise specified.

2-9. Localizing Troubles

a. General. Procedures are outlined in table 2-4 to localize troubles to a module, assembly, or chassis part of the RT-662/GRC or RT-834/GRC. Depending on the nature of the

operational symptoms, one or more of the localizing procedures will be necessary.

NOTE

Table 2-4 does not include trouble analysis procedures for 100 Hz synthesis of RT-834/GRC. Refer to section IV, table 2-5.

b. Use of Table. Table 2-4 supplements the operational procedures and troubleshooting information described in TM 11-5820-520-12. If previous operational checks have resulted in reference to a particular item of this table, go directly to the referenced item. If no operational symptoms are known, begin with the monthly preventive maintenance checks and services chart (TM 11-5820-520-12) and proceed until the trouble is located. It is assumed that, before starting a procedure for any given item of the table, any module removed in a previous procedure will be replaced. Procedures for module removal and replacement are found in section VI of this chapter.

c. Parts Identification and Location.

- (1) Module locations are shown in figure 2-26.
- (2) Identification of pin numbers of connectors (fig. 2-5 and 2-6) can be made by the removal of the modules (para 2-17) and examination of the connector markings.
- (3) All terminals, such as 1A1E14, are letter-stamped on the chassis, adjacent to the terminal, for identification purposes (fig. 2-28 and 2-29).

(4) To identify and locate a part, not shown in figures 2-5, 2-6, or 2-23 through 2-27, refer to the complete reference designation (para 2-5) to determine the approximate area of location (fig. 2-25 and 2-27). Each part is identified by letter-stamping on the chassis or printed board at its location.

d. Conditions for Test. Except for resistance measurements and continuity checks, all checks in the chart are to be conducted with the RT-662/GRC or RT-834/GRC connected to a power source as described in paragraph 2-8. Before performing the procedures outlined in

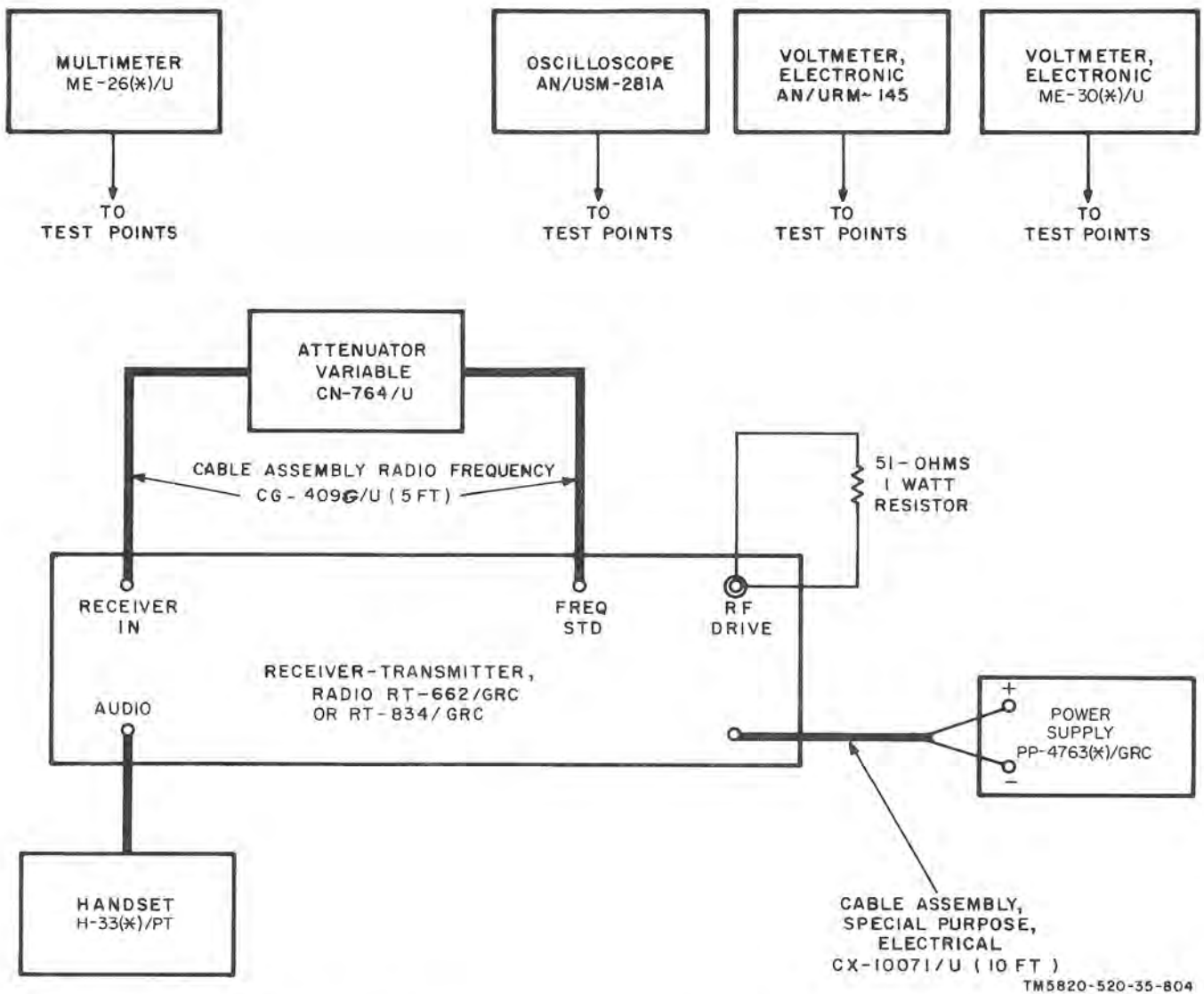

TM5820-520-35-804

Figure 2-4. Test setup for troubleshooting RT-662/GRC and RT-834/GRC.

table 2-4, turn on all test equipment and allow a 10-minute warmup period. Turn the RT-662/GRC or RT-834/GRC SERVICE SELECTOR switch to STANDBY and allow a 10-minute warmup period. After the warmup period is completed, set the SERVICE SELECTOR switch at SSB/NSK and adjust the CN-764/U for a 1 mv input level at the RECEIVER IN connector. To check or test components mounted on the bottom of the chassis, remove the bottom plate (para 2-8a).

NOTE

For those RT-662/GRC (serial numbers 1 through 220) which may require troubleshooting on 1A1A6, figure 4-30 has been provided.

CAUTION

Before making any resistance measurements or continuity checks in the procedures of the table, make sure that no power is applied to the RT-662/GRC or RT-834/GRC.

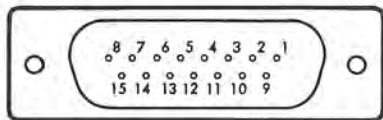

1A1XA11 (1A11J1)
 1A1XA10 (1A10J1)
 2A1A1XA7 (2A7J1)
 2A6A1PI (2A6J1)
 2A6XA1 (2A1J1)

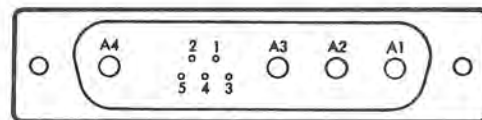

1A1XA2 (1A2J1)
 1A1XA6A (1A6J1A)
 1A1XA8A (1A8J1A)
 1A1XA8B (1A8J1B)
 2A1A1XA8 (2A8J1)

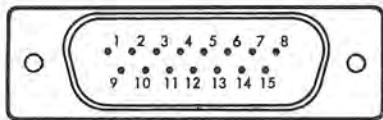

1A11J1 (1A1XA11)
 1A10J1 (1A1XA10)
 2A7J1 (2A1A1XA7)
 2A6J1 (2A6A1PI)
 2A1J1 (2A6XA1)

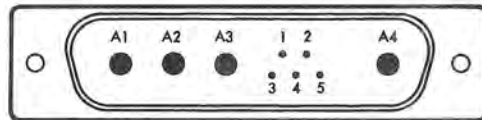

1A2J1 (1A1XA2)
 1A6J1A (1A1XA6A)
 1A8J1A (1A1XA8A)
 1A8J1B (1A1XA8B)
 2A8J1 (2A1A1XA8)

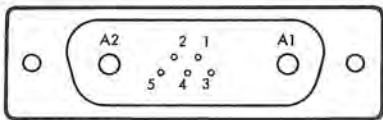

1A1XA3A (1A3J1A)
 1A1XA4A (1A4J1A)
 1A1XA9 (1A9J1)

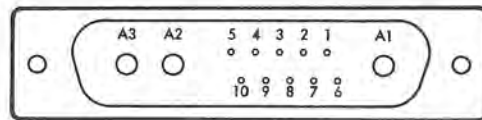

1A1XA12 (1A12J1)

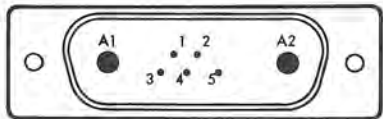

1A3J1A (1A1XA3A)
 1A4J1A (1A1XA4A)
 1A9J1 (1A1XA9)

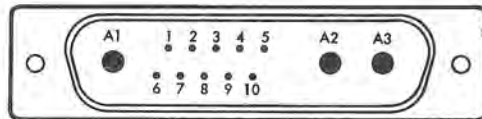

1A12J1 (1A1XA12)

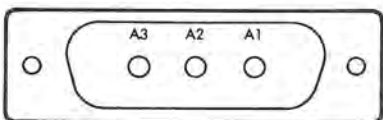

1A1XA3B (1A3J1B)
 1A1XA4B (1A4J1B)
 1A1XA6B (1A6J1B)

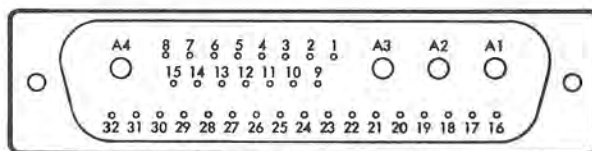

1A1XA5 (1A5J1)
 1A1XA7 (1A7J1)
 2A1XA5 (2A5J1)

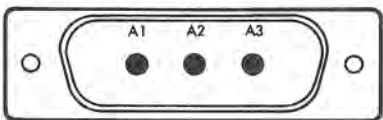

1A3J1B (1A1XA3B)
 1A4J1B (1A1XA4B)
 1A6J1B (1A1XA6B)

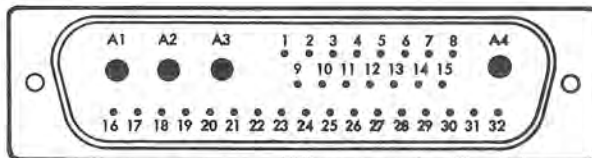

1A5J1 (1A1XA5)
 1A7J1 (1A1XA7)
 2A5J1 (2A1XA5)

TM5820-520-35-805

Figure 2-5. Pin number identification, internal connectors.

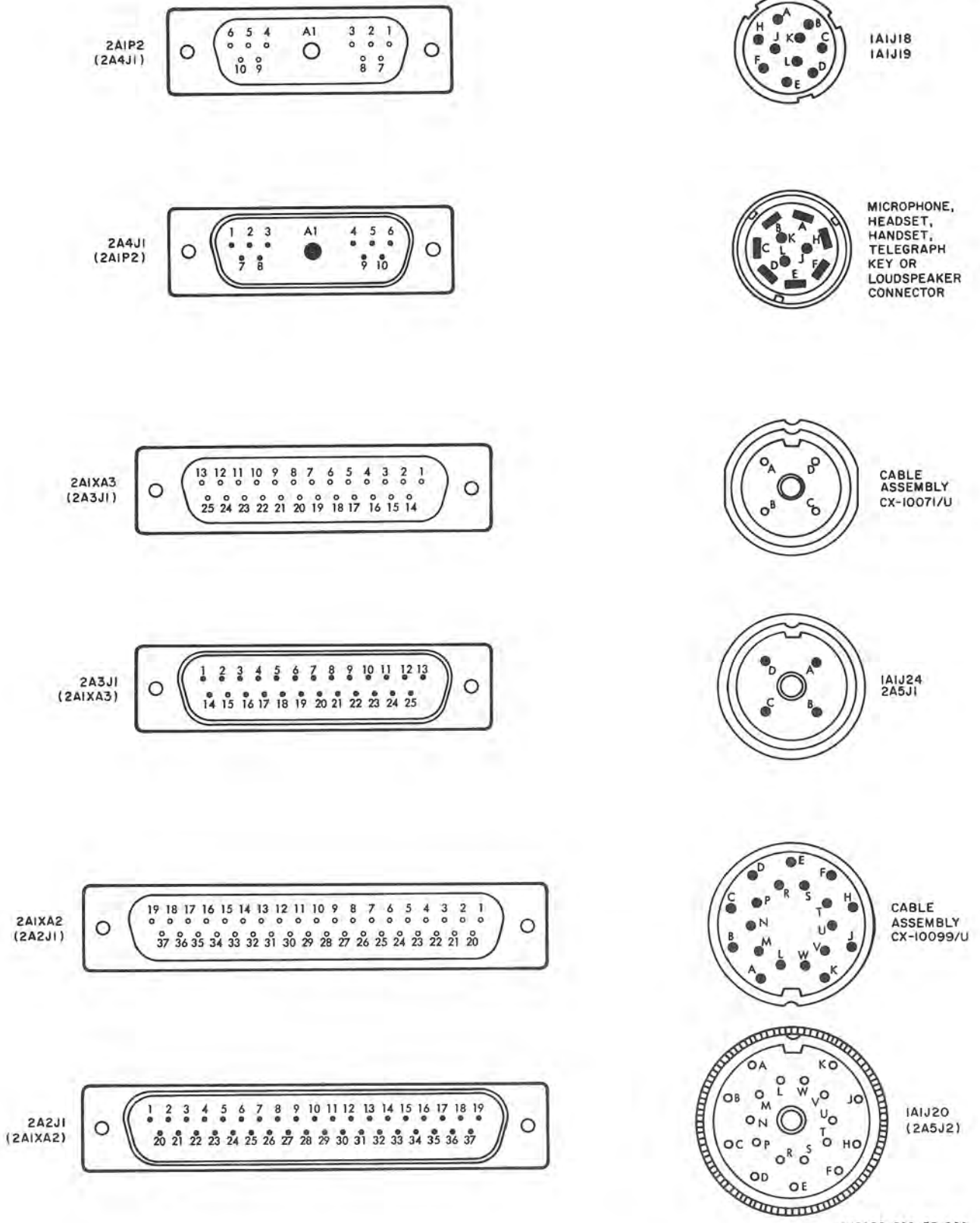

TM5820-520-35-806

Figure 2-6. Pin number identification, internal and external connectors.

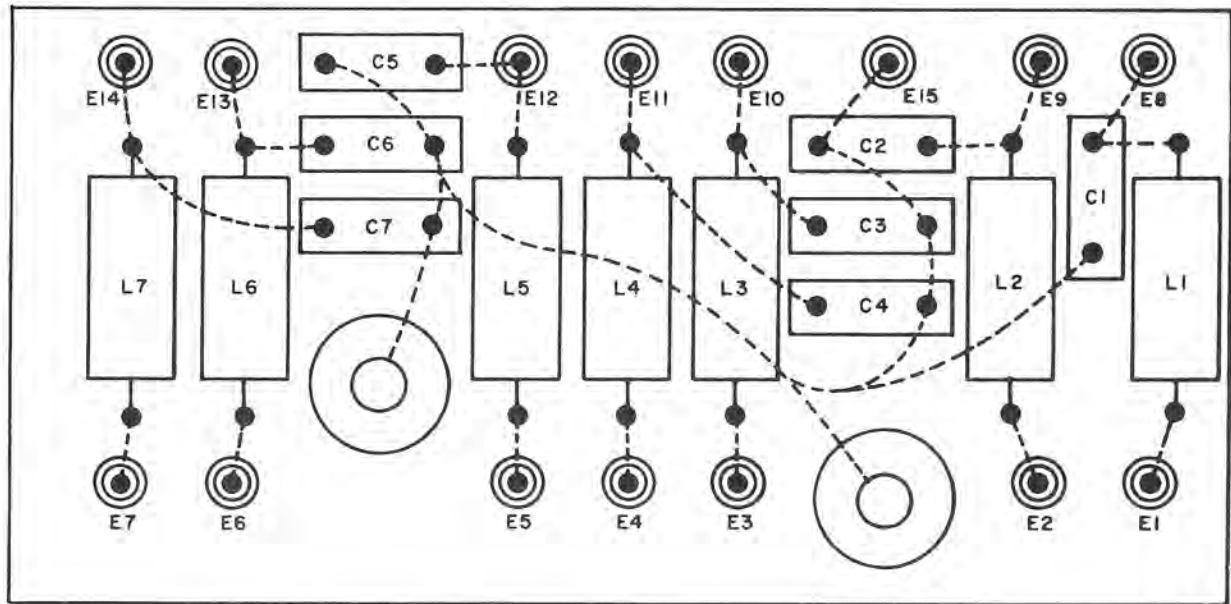

1. CIRCUIT VIEWED FROM SIDE ON WHICH PARTS ARE MOUNTED.
2. ——— PARTS AND PIGSTAILS ON FRONT OF BOARD.
3. - - - - WIRING ON BACK OF BOARD.
4. ASSEMBLY 1A1A3 DOES NOT CONTAIN A C6.

TM5820-520-35-807

Figure 2-7. Printed circuit boards 1A1A2, 1A1A3, and 1A1A4 parts, location.

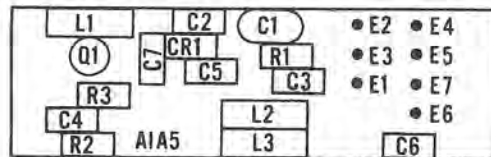

TM5820-520-35-808

Figure 2-8. RT-662/GRC and RT-834/GRC Internal Alc Assembly 1A1A5, parts location diagram.

Table 2-4. Troubleshooting RT-662/GRC or RT-834/GRC

Item	Indication	Probable trouble	Procedure
1	No, or inaccurate, output at FREQ STD connector.	Defective frequency standard module 1A3, dc-to-dc converter and regulator module 1A11, or wiring.	<ol style="list-style-type: none"> (1) Note indication on signal level meter. If zero, proceed to (2) below. If full-scale, proceed to item 4. If voltage level was out of tolerance in paragraph 2-4c, proceed to (5) below. (2) Be sure that INT-EXT switch on top of frequency standard module 1A3 is set at INT. (3) Remove frequency standard module 1A3 (Para 2-17b) and check for 19.5 ± 0.5 volts dc at pin 2 of connector 1A1XA3A (fig. 2-5). If voltage is present, proceed to (4) below. If voltage is not present, wiring between pin 2 of connector 1A1XA3A and terminal 1A1E4 (fig. 2-28) is defective. (4) Check wiring between FREQ STD connector 1A1J22 and 1A1XA3A-A2 for continuity and short circuit to ground. If wiring is continuous and not shorted, frequency standard module 1A3 is defective. (5) Remove frequency standard module 1A3 and check for 27 ± 3 volts dc at pin 3 of connector 1A1XA3A (fig. 2-25). If voltage is present, frequency standard module 1A3 is defective. If not present, wiring between pin 3 of connector 1A1XA3A and terminal 1A1E40 (fig. 2-28) is defective.

Table 2-4. Troubleshooting RT-662/GRC or RT-834/GRC—Continued

Item	Indication	Probable trouble	Procedure
2	Fuse 1A1F1 burns out when SERVICE SELECTOR switch 1A1S4 is set only at OVEN ON.	<p>a. Defective capacitors 1A1C50, 1A1C51, and 1A1C54, frequency standard module 1A3, wiring, voltage protection circuit, or resistor 1A1R17.</p> <p>b. Defective regulator circuit.</p>	<p>(1) Check for short circuit in frequency standard module 1A3, by removing it and checking to see if short is still present.</p> <p>(2) Check resistor 1A1R17, by measuring resistance to ground, with frequency standard module 1A3 removed. If resistance is 2 ohms, diode 1A1VR2 is defective.</p> <p>(3) If a short is present with frequency standard module 1A3 removed, capacitors 1A1C50, 1A1C51, and 1A1C54 could be defective.</p> <p>Check resistor 1A1R17 and capacitor 1A1C50.</p>
3	Fuse 1A1F1 burns out when SERVICE SELECTOR switch 1A1S4 is set at STANDBY.	Defective transmitter IF and audio module 1A5, or dc-to-dc converter and regulator module 1A11, or standby 17 volt distribution path.	Check for short circuit in transmitter IF and audio module 1A5 and dc-to-dc converter and regulator module 1A11 by removing both modules and then replacing them one at a time to see which is causing the short. Also, check associated 27 volt dc standby distribution path wiring (fig. 4-33) for short circuit to ground.
4	Signal level meter does not deflect full scale with SERVICE SELECTOR switch set at STANDBY.	<p>a. Defective dc-to-dc converter and regulator module 1A11.</p> <p>b. Defective receiver IF module 1A7, wiring, relay 1A1K1, or signal level meter 1A1M1.</p> <p>c. Defective signal level 1A1M1.</p> <p>d. Defective transmitter IF and audio module 1A5, or wiring.</p> <p>e. Defective wiring, filter 1A1FL1, SERVICE SELECTOR switch 1A1S4, capacitor</p>	<p>(1) Check for -33 ± 1.5 volts dc at -30VDC test point on top of dc-to-dc converter and regulator module 1A11. If voltage is present, proceed to <i>b</i> below. If not present, proceed to (2) below.</p> <p>(2) Remove dc-to-dc converter and regulator module 1A11 (Para 2-17<i>b</i>). Check for 23 to 29 volts dc at pin 7 of connector 1A1XA11 (fig. 2-5 and 2-25). If voltage is present, dc-to-dc converter module 1A11 is defective. If voltage is not present, proceed to <i>c</i> below.</p> <p>(1) Check for -0.2 to 0.6 volts dc between terminal 1 of signal level meter 1A1M1 (fig. 2-25) and ground. If indication is present, signal level meter 1A1M1 is defective. If indication is not present, proceed to (2) below. If indication is -23.5 to -25.5 volts dc, proceed to <i>c</i> below.</p> <p>(2) Remove receiver IF module 1A7 (Para 2-17<i>b</i>) and dc-to-dc converter and regulator module 1A11. Check continuity between pin 14 of connector 1A1XA11 and pin 6 of connector 1A1XA7 (fig. 2-5). If continuity exists, proceed to (3) below. If there is no continuity, interconnecting wiring or relay 1A1K1 is defective.</p> <p>(3) Check for continuity between pin 7 of connector 1A1XA7 and terminal 1 of signal level meter 1A1M1. If there is continuity, receiver IF module 1A7 is defective. If there is no continuity, wiring is defective.</p> <p>Set ME-26(*)/U at OHMS, RX10K range and connect it across signal level meter 1A1M1. Some deflection should be noted on signal level meter 1A1M1. If there is deflection, proceed to <i>d</i> below. If there is no deflection, signal level meter 1A1M1 is defective.</p> <p>Remove transmitter IF and audio module 1A5 (Para 2-17<i>b</i>). Check continuity between terminal 2 of signal level meter 1A1M1 and pin 4 of connector 1A1XA5 (fig. 2-5). (1A1M1 will give full scale deflection.) If there is continuity, transmitter IF and audio module 1A5 is defective. If there is no continuity, wiring is defective.</p> <p>Disconnect PP-4763/GRC from the POWER connector. Check continuity between pin B of POWER connector 1A1J24 (fig. 2-6) and pin 7 of connector 1A1XA11 (fig. 2-25). If there is no continuity, diode 1A1CR1,</p>

Table 2-4. Troubleshooting RT-662/GRC or RT-834/GRC—Continued

Item	Indication	Probable trouble	Procedure
5	Fuse 1A1F1 burns out when SERVICE SELECTOR switch 1A1S4 is set at AM, FSK, SSB/NSK, or CW.	<p>1A1C50 or 1A1C51, or polarity diode 1A1CR1.</p> <p>a. Defective dc-to-dc converter and regulator module 1A11 or receiver audio module 1A10.</p>	<p>wiring, SERVICE SELECTOR switch 1A1S4, or filter 1A1FL1 is open (ohmmeter leads may have to be reversed). Ⓢ</p> <p>Check for short circuit in dc-to-dc converter and regulator module 1A11 and receiver audio module 1A10 by removing both modules and then replacing one at a time to see which is causing the short.</p>
6	Signal level meter does not return to zero with SERVICE SELECTOR switch set at an operate position.	<p>b. Defective operate 27 volt dc distribution path.</p> <p>Defective dc-to-dc converter and regulator module 1A11, wiring, transistor 1A1Q1, resistor 1A1R1, relay 1A1K1, or receiver IF module 1A7.</p>	<p>Check capacitor 1A1A5C48, 1A1C52, or 1A1C53 and the associated wiring for short circuit to ground.</p> <p>(1) Check for 19.5 ±0.5 volts dc at +20 VDC REG test point on top of dc-to-dc converter and regulator module 1A11. If present, remove receiver IF module 1A7, measure for 20 volts dc at connector 1A1XA7-1. If present, receiver IF module 1A7 is defective. If 20 volts dc is not present at +20 VDC Reg test point on top of dc-to-dc converter and regulator module 1A11, proceed to (2) below. If voltage is higher than 20 volts dc, remove dc-to-dc converter and regulator module 1A11 and check continuity between emitter of transistor 1A1Q1 and pin 15 of connector 1A1XA11 (fig. 2-5). If there is continuity, dc-to-dc converter and regulator module 1A11 is defective. If there is no continuity, wiring is defective. If 20 volts dc is not present at pin 1 of connector 1A1XA7, check continuity between pin 1 of connector 1A1XA7 and pin 15 of connector 1A1XA11. Not present, check relay 1A1K1 or resistor 1A1R1.</p> <p>(2) Remove dc-to-dc converter and regulator module 1A11. Measure resistance between pins 13 and 8 of connector 1A11J1 (fig. 2-5). If indication is approximately 47 ohms, dc-to-dc converter and regulator module 1A11 is defective. If indication is infinity, reverse connection of ME-26(*)/U leads. If indication is approximately 500K, transistor 1A1Q1 is defective. If indication remains at infinity, dc-to-dc converter and regulator module 1A11 is defective.</p>
7	Fuse 1A1F1 burns out during tuning cycle.	Defective motor 1A1B1 or relay 1A1K2.	Check for shorted winding in motor 1A1B1 and coil in relay 1A1K2 or voltage regulator 1A1VR1.
8	Inaccurate tuning code to turret in rf amplifier module 1A12 and an accurate tuning code to AM-3349/GRC-106.	<p>a. Defective motor code switch 1A1S9 or wiring.</p> <p>b. Defective motor 1A1B1, motor relay 1A1K2, or wiring.</p>	<p>Connect pin 7 of motor relay 1A1K2 to ground. If motor 1A1B1 rotates, motor code switch 1A1S9 or interconnecting wiring is defective. Check for open wires and bent or broken contacts. If motor does not rotate, proceed to b below.</p> <p>(1) Check for 27 volts dc at contact 5 of motor relay 1A1K2. If voltage is present, proceed to (2) below. If voltage is not present, wiring between contact 5 of motor relay 1A1K2 and contact 4 of section 1, front of SERVICE SELECTOR switch 1A1S4 is defective.</p>

Table 2-4. Troubleshooting RT-662/GRC or RT-834/GRC—Continued

Item	Indication	Probable trouble	Procedure
9	No transmit or receive.	a. Defective mechanical coupling.	<p>(2) Connect ME-26(*)/U to contact 8 of motor relay 1A1K2. Jumper contact 7 of motor relay 1A1K2 to ground. The ME-26(*)/U indication should go from 27 volts dc to zero. If indication is correct, motor 1A1B1 is defective. If indication is not correct, motor relay 1A1K2 is defective.</p>
		b. Defective dc-to-dc converter and regulator module 1A11 or wiring.	<p>(1) Insure that the number appearing in the MEGA-CYCLE window on top of rf amplifier module 1A12 corresponds with the setting of the MHz controls on the front panel. If not, turn off power, remove module 1A12 for chassis, and turn MHz controls to the number showing on top of the 1A12 module. Apply power to the unit. Turn SERVICE SELECTOR switch to SSB/NSK. Allow tuning motor to cycle completely. Remove power from the unit and reinstall 1A12 module. If unit still does not operate, proceed to step (2).</p> <p>(2) Remove rf amplifier module 1A12 (Para 2-17f), MHz synthesizer module 1A9 (Para 2-17e), 10 and 1 kHz synthesizer module 1A4, (para 2-17d) and 100 kHz synthesizer module 1A2 (Para 2-17c). For each module, compare position of couplers on bottom of module with corresponding couplers on chassis (fig. 2-25) to insure that there is proper positioning. Correct positioning if necessary and replace four modules into chassis. Proceed to b below.</p> <p>(1) Check for 125 ± 10 volts dc at +125 VDC test point on top of dc-to-dc converter and regulator module 1A11. If not present, proceed to (4) below. If present, proceed to (2) below.</p> <p>(2) Check for 6.3 ± 0.5 volts ac square wave (5 kc) at 6.3 VAC test points on top of dc-to-dc converter and regulator module 1A11, using AN/USM-281. If not present, proceed to (4) below. If present, proceed to (3) below.</p> <p>(3) Check for $+20 \pm 0.5$ volts dc at +20 VDC test point on top of dc-to-dc converter and regulator module 1A11. If present, proceed to c below. If not present, proceed to (5) below.</p> <p>(4) Remove dc-to-dc converter and regulator module 1A11. Check for 23 to 29 volts dc at pin 7 of connector 1A1XA11. If voltage is present, dc-to-dc converter and regulator module 1A11 is defective.</p> <p>(5) Remove dc-to-dc converter and regulator module 1A11. Check for 23 to 29 volts dc at pin 15 of connector 1A1XA11. If voltage is not present, proceed to e below. If voltage is present, dc-to-dc converter and regulator module 1A11 is defective.</p>
		c. Defective rf amplifier module 1A12, relay 1A1K3, capacitor 1A1A7C49, or wiring.	<p>(1) Set agc-alc 1A1S11 (fig. 2-43) at off. Set CN-764/U attenuator for an approximate 1 mv (0 dbm) input signal level at terminal 1A1A7E9 (fig. 2-28) of 1A1J26 (fig. 2-25). Connect AN/URM-145 to RF OUTPUT test point on top of rf amplifier module 1A12. An indication of 45 ± 6 db above input signal level should be present. If indication is present, proceed to d below. If indication is not present, proceed to (2) below.</p>

Table 2-4. Troubleshooting RT-662/GRC or RT-834/GRC—Continued

Item	Indication	Probable trouble	Procedure
d.	Defective translator module 1A8, receiver IF module 1A7, wiring, relay 1A1K4, or frequency dividers module 1A6.		<p>(2) Remove dc-to-dc converter and regulator module 1A11 (Para 2-17b) and rf amplifier module 1A12 (Para 2-17f). Isolate defect by checking following connections for continuity; pin 6 of connector 1A1XA11 (fig. 2-25) to pin 5 of connector 1A1XA-12; Pin 9 of connector 1A1XA11 to pin 1 of connector 1A1XA12 (fig. 2-5); and pin 1 of connector 1A1XA11 to pin 6 of connector 1A1XA12. Check continuity between connectors 1A1J16 and 1A1XA12-A3 by checking for presence of signal at 1A1XA12-A3 with AN/URM-145. Also, check wiring between connectors 1A1J16 and 1A1XA12-A3 to insure that there are no short circuits to ground.</p> <p>(1) Connect AN/URM-145 to RF OUTPUT test point on top of rf amplifier module 1A12. Set CN-764/U for an approximate 20 mv indication on AN/URM-145. Connect AN/USM-281A to RCVR OUT test point on top of translator module 1A8 and note indication. If there is no output, proceed to (2) below. If low level modulated output (2.85 MHz) is present, proceed to e(1) below. If sine wave output is present, proceed to f below. If modulated signal (1.75 MHz) at a minimum amplitude of 100 mv peak-to-peak is present, connect AN/URM-145 to SSB FIL OUTPUT test point on top of receiver IF module 1A7 and check for 0.2 to 0.4 mv signal. If present, frequency dividers module 1A6 is defective. If not present, receiver IF module 1A7 is defective.</p> <p>(2) Remove translator module 1A8 (Para 2-17b) and check for 19.5 ± 0.5 volts dc at pin 1 of connector 1A1XA8A. If present, proceed to (3) below. If voltage is not present, wiring between pin 1 of connector 1A1XA8A (fig. 2-5) and terminal 1A1E45 (fig. 2-28) defective.</p> <p>(3) Using ME-26(*)/U, check continuity between pin 2 of connector 1A1XA8A and ground. If there is continuity, proceed to (4) below. If there is no continuity, wiring between pin 2 of connector 1A1XA8A and ground is defective.</p> <p>(4) Using ME-26(*)/U, check for 19.5 ± 0.5 volts dc at pin 3 of connector 1A1XA8A. If present, proceed to (5) below. If not present, defect is in wiring between pin 3 of connector 1A1XA8A and contact 10 of relay 1A1K1 (fig. 2-27).</p> <p>(5) Using the ME-26(*)/U, check for 19.5 ± 0.5 volts dc at pin 4 of connector 1A1XA8A. If present, proceed to (6) below. If not present, proceed to f(5) below.</p> <p>(6) Using ME-26(*)/U, check continuity to ground between pin 5 of connector 1A1XA8A and ground. If there is continuity, proceed to (7) below. If there is no continuity, wiring between pin 5 of connector 1A1XA8A and 12 of relay 1A1K1 (fig. 2-27) is defective.</p> <p>(7) Connect AN/URM-145 to connector 1A1XA8B-A2 and check for an indication (approx. 100 mv). If present, proceed to (8) below. If not present, wiring between connector 1A1XA12-A1 and contact A3 of relay 1A1K4 or relay 1A1K4 is defective.</p>

Table 2-4. Troubleshooting RT-662/GRC or RT-834/GRC—Continued

Item	Indication	Probable trouble	Procedure
			<p>(8) Using AN/URM-145, check at 1A1XA8A-A1 for 10 and 1 kHz injection signal (4.552 MHz) at a minimum level of 90 mv. If signal is present, proceed to (9) below. If not present, proceed to e below.</p> <p>(9) Using AN/URM-145, check at connector 1A1XA8B-A1 (fig. 2-5) for megahertz injection signal (15.5 MHz \pm 2 Hz) at a minimum level of 40 mv. If signal is present, proceed to f below.</p> <p>(10) Using AN/URM-145, check at connector 1A1XA8A-A4 for presence of 100 kHz injection signal (23.3 MHz \pm 400 Hz) at minimum level of 100 mv. If signal is present, translator module 1A8 is defective. If not present, proceed to f(4) below.</p>
	e. Defective 10 and 1 kHz synthesizer module 1A4, translator module 1A8, or wiring.		<p>(1) Replace translator module 1A8 into chassis. Using AN/URM-145, check for presence of 10 and 1 kHz injection signal (4.552 MHz \pm 400 Hz) at level of 120 \pm 30 mv at 10 & 1 kHz SYNTH OUP T test point on top of 10 and 1 kHz synthesizer module 1A4. If there is no, or low, output, proceed to (2) below. If correct signal is present, check wiring between connectors 1A1XA8A-A1 and 1A1XA4B-A3 (fig. 2-5) for defects. If no defects are found, 10 and 1 kHz synthesizer module 1A4 is defective.</p> <p>(2) Remove 10 and 1 kHz synthesizer module 1A4 and check for 19.5 \pm 0.5 volts dc at pin 5 of connector 1A1XA4A (fig. 2-5). If voltage is present, 10 and 1 kHz synthesizer module 1A4 is defective. If not present, wiring between pin 5 of connector 1A1XA4A (fig. 2-5) and terminal 1A1E45 (fig. 2-28) is defective.</p>
	f. Defective 100 kHz synthesizer module 1A2, frequency standard module 1A3, 10 and 1 kHz synthesizer module 1A4, frequency dividers module 1A6, translator module 1A8, MHz synthesizer module 1A9, or wiring.		<p>(1) Replace translator module 1A8 into chassis. Connect AN/URM-145 to MHz SYNTH OUP T test point on top of MHz synthesizer module 1A9 and check for megahertz injection signal (15.5 MHz \pm 10 Hz) level greater than 30 mv. If indication is not present, rotate MHz controls through each position and note AN/URM-145 indication. If there are indications at only some of the settings, MHz synthesizer module 1A9 is defective. If there is no indication at any setting, set MHz controls at 04 and proceed to (2) below. If indications are correct, remove MHz synthesizer module 1A9 (Para 2-17e) and translator module 1A8 (Para 2-17b). Check wiring between connectors 1A1XA8B-A1 (fig. 2-5) and 1A1XA9-A2 for defects. If no defect is found, MHz synthesizer module 1A9 is defective.</p> <p>(2) Check for 19.5 \pm 0.5 volts dc at pin 5 of connector 1A1XA9 with ME-26(*)/U. Using the AN/USM-281A, check for signal (1 MHz \pm 2 Hz) with a minimum level of 1.3 volts peak-to-peak sine wave at connector 1A1XA9-A1. If both indications are present, but indication in (1) above was not present or was out of tolerance, replace MHz synthesizer module 1A9. If 1 MHz signal is not present or is out of tolerance, proceed to (3) below. If 19.5 \pm 0.5 volts dc is not present, wiring between pin 5 of connector 1A1XA9 and terminal 1A1E45 (fig. 2-28) is defective.</p>

Table 2-4. Troubleshooting RT-662/GRC or RT-834/GRC—Continued

Item	Indication	Probable trouble	Procedure
			(3) Using AN/USM-281A at 1 MHz OUPPT test point on top of frequency standard module 1A3, check for presence of signal (1 MHz \pm 2 Hz) with minimum level of 1.2 volts peak-to-peak. If not present, or out of tolerance, frequency standard module 1A3 is defective. If present, check wiring between connectors 1A1XA9-A1 and 1A1XA3B-A1 (fig. 2-5) for defects. If no defects are found, replace frequency standard module 1A3.
			(4) Set AN/URM-145 MHz control to 05, 100 kHz control to 9. Connect AN/URM-145 to 100 kHz SYNTH OUPPT test point on top of 100 kHz synthesizer module 1A2. Check signal for (23.3 MHz \pm 400 Hz using AN/USM-207) level of 100 \pm 15 mv. If indication is correct remove translator module 1A8, check for signal level of 120 \pm 15 mv at 1A1XA8A-A4. If indication is correct, translator module 1A8 is defective. If signal is not present at 1A1XA8A-A4, check wiring between 1A1XA8A-A4 and 1A1XA2-A4. If no defect is found, 100 kHz synthesizer module 1A2 is defective. If no indication is noted on 100 kHz synthesizer module 1A2 rotate the 100 kHz control through each of its positions. If an output is noted on AN/URM-145 at other positions of 100 kHz control 100 kHz synthesizer module 1A2 is defective. If indications still are not obtained, return 100 kHz control to position 9, and proceed to (5) below. If indication is out of tolerance, proceed to (6) below.
			(5) Remove MHz synthesizer module 1A9 (para 2-17e) and check for continuity between pin 4 of connector 1A1XA8A and pin 2 of connector 1A1XA9. If there is continuity, MHz synthesizer module 1A9 is defective. If there is no continuity, wiring is defective.
			(6) Connect AN/URM-145 to 7.1 MHz OUPPT test point on top of 10 and 1 kHz synthesizer module 1A4. Check for level of 35 \pm 10 mv (7.1 MHz \pm 400 Hz). If indication is correct, proceed to (7) below. If level of 7.1-MHz signal is out of tolerance, check wiring between connectors 1A1XA4B-A1 and 1A1XA2-A2 for defects. If no defect is found, 10 and 1 kHz synthesizer module 1A4 is defective.

NOTE

Check for 7.089 MHz in the RT-834/GRC.

- (7) Remove 100 kHz synthesizer module 1A2 (para 2-17c) and check for 19.5 \pm 0.5 volts dc at pin 3 of connector 1A1XA2. If present, proceed to (8) below. If not present, check wiring between pin 3 of connector 1A2XA2 and terminal 1A1E45 for defects.
- (8) Check for 19.5 \pm 0.5 volts dc at pin 1 of connector 1A1XA2. If present, proceed to (9) below. If not present, wiring between pin 1 of connector 1A1XA2 and pin 1 of connector 1A1XA9 is defective.
- (9) Connect AN/USM-281A to connector 1A1XA2-A3 and check for spectrum with prr of 10 microseconds, pulse width of 0.8 \pm 0.1 microsecond at 50% amplitude, and minimum amplitude of 600 mv (a, fig. 4-28). If not present, proceed to (10) below. If present, insert new 100 kHz synthesizer module into chassis. If correct indications can now

Table 2-4. Troubleshooting RT-662/GRC or RT-834/GRC—Continued

Item	Indication	Probable trouble	Procedure
			be obtained, original 100 kHz synthesizer module 1A2 was defective. If still no output is present, frequency dividers module 1A6 is defective.
(10)			Using high impedance probe, connect AN/USM-281A to 100 kHz SPEC OUP T test point on top of frequency dividers module 1A6 and check for spectrum with 625 ± 75 mv peak-to-peak amplitude, pulse width of 0.8 ± 0.1 microsecond at 50% amplitude (fig. 4-28, j and k), and prr of 10 microseconds. If not present, proceed to (15) below. If present, check wiring between connectors 1A1XA6A-A4 and 1A1XA2-A3 for defects. If no defect is found, frequency dividers module 1A6 is defective.
(11)			Remove 10 and 1 kHz synthesizer module 1A4 (para 2-17d). Using AN/USM-281A, check for 10 kHz input spectrum (2.48 to 2.57 MHz with prr of 100 microseconds, width of 8 ± 1 microseconds, and minimum amplitude of 1.6 volts peak-to-peak (f, fig. 4-28) at connector 1A1XA4A-A1. If present, proceed to (12) below. If not present, proceed to (13) below.
(12)			Using AN/USM-281A, check for 1 kHz pulse input with prr of 1 millisecond, width of 4.4 ± 0.4 microseconds, and minimum amplitude of 1.5 volts peak-to-peak at connector 1A1XA4A-A2. If not present, proceed to (13) below. If present, replace 10 and 1 kHz synthesizer module 1A4 into the chassis.
(13)			Replace 10 and 1 kHz synthesizer module 1A4 into chassis. Using high impedance probe, connect AN/USM-281A to 10 kHz SPEC OUP T test point on top of frequency dividers module 1A6, and check for spectrum with following characteristics: 90 mv peak-to-peak minimum amplitude, width of 8 ± 1 microseconds at 50% amplitude, and prr of 100 microseconds (fig. 4-28, q and r). Also, check at 1 kHz PULSE OUT test point on top of frequency dividers module 1A6 for a pulse with 1.0 volts peak-to-peak minimum amplitude, width of 4.4 ± 0.4 microseconds at 50% amplitude and prr of 1 millisecond. If neither indication is present, proceed to (14) below. If spectrum is present but pulse is not present, check wiring between connectors 1A1XA6A-A1 and 1A1XA4A-A2 for defects. If pulse is present but spectrum is not present, check wiring between connectors 1A1XA6B-A1 and 1A1XA4A-A2 for defects. If no defect is found, frequency dividers module 1A6 is defective.
(14)			Remove frequency dividers module 1A6 (para 2-17b) and check for 19.5 ± 0.5 volts dc at pin 3 of connector 1A1XA6A. If voltage is present, proceed to (15) below. If not present, wiring between terminal 1A1E45 and pin 3 of connector 1A1XA6A is defective.
(15)			Connect AN/USM-281A to connector 1A1XA6A-A3 and check for signal (500 kHz) with minimum amplitude of 550 mv peak-to-peak. If present, frequency dividers module 1A6 is defective. If not present, check for this signal at minimum amplitude of 180 mv at 500 kHz OUP T test point on top of frequency standard module 1A3. If not

Table 2-4. Troubleshooting RT-662/GRC or RT-834/GRC—Continued

Item	Indication	Probable trouble	Procedure
10	No transmission and reception, or poor receiver sensitivity and insufficient transmit rf drive, at following setting of the MHz controls: 2, 3, 4, 5, 7, 8, 11, 12, 14, 15, 16, 22, 23, 27, 28, or 29.	Defective MHz synthesizer module 1A9, translator module 1A8, 100 kHz synthesizer module 1A2, or wiring.	<p>present, frequency standard module 1A3 is defective. If signal is present, check wiring between connectors 1A1XA3A-A1 and 1A1XA6A-A3 for defects. If no defect is found, frequency standard module 1A3 is defective.</p> <ol style="list-style-type: none"> (1) Connect AN/URM-145 to 100 kHz SYNTH OUPT test point on top of 100 kHz synthesizer module 1A2. Check for signal (23.3 MHz \pm400 Hz) at level of 110 \pm15 mv. If indication is correct, proceed to (3) below. If indication is not present, 100 kHz synthesizer module 1A2 is defective. If indications are out of tolerance, proceed to (2) below. (2) Remove 100 kHz synthesizer module 1A2 (para 2-17c) from chassis and check for 19.5 \pm0.5 volts dc at pin 1 of connector 1A1XA2 (fig. 2-25). If present, 100 kHz synthesizer module 1A2 is defective. Check for continuity between pin 1 of connectors 1A1XA9 and 1A1XA2. If there is continuity, MHz synthesizer module 1A9 is defective. If there is no continuity, wiring is defective. (3) Remove translator module 1A8 (para 2-17b) and check for 19.5 \pm0.5 volts dc at pin 4 of connector 1A1XA8A. If present, translator module 1A8 is defective. If not present, check for continuity between pin 2 of connector 1A1XA9 and pin 4 of connector 1A1XA8A. If there is continuity, MHz synthesizer module 1A9 is defective. If there is no continuity, wiring is defective.
11	No transmission or reception at following settings of MHz controls: 6, 9, 10, 13, 17, 18, 19, 20, 21, 24, 25, and 26.	Defective frequency standard module 1A3, 100 kHz synthesizer module 1A2, translator module 1A8, or wiring.	<ol style="list-style-type: none"> (1) Set MHz controls to 09, 100 kHz control to 9. Check frequency at 100 kHz SYNTH OUPT test point on top of 100 kHz synthesizer module 1A2 (33.3 MHz using AN/USM-207). Check signal for level of 120 mv (AN/URM-145) minimum. If not present proceed to (2) below. (2) Remove 100 kHz synthesizer module 1A2 (para 2-17c). Use an AN/USM-281A, to check for signal (10 MHz) at connector 1A1XA2-A1 with approximate level of 100 mv peak-to-peak. If present proceed to (3) below. If not present proceed to (4) below. (3) With 100 kHz synthesizer module 1A2 removed, check for ground (ME-26(*)/U) at connector 1A1XA2-1. If present proceed to (4) below. (4) Check for signal (10 MHz) at 10 MHz OUPT test point on top of frequency standard module 1A3 (AN/USM-281A). If signal is not present here, check for signal (5 MHz) OUPT test point on top of frequency standard module 1A3. Signal present, frequency standard module 1A3 is defective. Signal not present, remove frequency standard module 1A3. Check for 19.5 \pm0.5 volts dc (ME-26(*)/U) at connector 1A1XA3A-2, if present frequency standard module 1A3 is defective. If signal (10 MHz) is present at 10 MHz OUPT test point of frequency standard module 1A3, remove the frequency standard module 1A3. Check continuity between connectors 1A1XA2-A1 and 1A1XA3B. If no defect is found, frequency standard 1A3 is defective.
12	No receive, but transmissions can be made.	DEFECTIVE relay 1A1K3, relay 1A1K4, translator module 1A8, receiver IF module	<ol style="list-style-type: none"> (1) Turn SERVICE SELECTOR switch to CW, AUDIO GAIN control fully clockwise, and BFO control fully clockwise. If tone can be heard, check for shorted capacitor 1A1A2C5 or 1A1C46, or contact

Table 2-4. Troubleshooting RT-662/GRC or RT-834/GRC—Continued

Item	Indication	Probable trouble	Procedure
		1A7, receiver audio module 1A10, AUDIO GAIN control 1A1R2, wiring, relay 1A1K1, or relay 1A1K3. Short across 1A1A10R1 or 1A1A10R2 (fig. 4-34); defective 1A1A10A1C1, or 1A1A10K1 or wiring on the 1A1A10 assembly.	on section 3, front of switch 1A1S4. If no tone is heard, depress and hold H-33(*)/PT push-to-talk switch. Tone should be heard in H-33(*)/PT receiver. If present, proceed to (2) below. If not present, proceed to (9) below.
			(2) Release H-33(*)/PT push-to-talk switch. Turn SERVICE SELECTOR switch to SSB/NSK. Connect AN/URM-145 to terminal 1A1A7E6 and check for signal. If present, proceed to (3) below. If not present, check wiring between connector 1A1J16 and terminal 1A1A10A1E5. Check to see if resistors 1A1A10R1 and 1A1A10R2 are defective or their wiring shorting input to ground. Check capacitor 1A1A10A1C1 (fig. 4-43 or 4-44) for being open, or shorted coax or defective relay 1A1A10K1.
			(3) Connect AN/URM-145 to the RF OUTPUT test point on top of RF amplifier module 1A12 and check for signal (approx 10 mv). If present, proceed to (4) below. If not present, relay 1A1K3 (fig. 4-33) or connection between terminal 1A1A7E6 (fig. 2-28) and contact A3 of relay 1A1K3 is defective.
			(4) Connect AN/USM-281A to RCVR OUPPT test point on top of translator module 1A8. Set agc/alc switch 1A1S11 at off. AN/USM-281A should indicate signal (1.752 MHz) at approximately 20 mv. If present, proceed to (8) below. If not present, proceed to (5) below.
			(5) Set MHz controls to 05, 100 kHz control to 9. Inject a 5 MHz signal at REC IN connector at a level of 10 microvolts. Remove translator module 1A8 (para 2-17b) and check for level of signal (minimum 30 millivolts) at connector 1A1XA8B-A2 with AN/URM-145. If present, proceed to (6) below. If not present, one of the following is defective: wiring between connector 1A1XA12-A1 and contact A2 of relay 1A1K4, or wiring between contact A3 and relay 1A1K4 and connector 1A1XA8B-A2, or relay 1A1K4.
			(6) Check for 19.5 ± 0.5 volts dc at pin 5 of connector 1A1XA8A. If present, relay 1A1K1 is defective. If not present, check for continuity to ground. If there is continuity, proceed to (7) below. If there is no continuity, there is defect in wiring to contact 12 of relay 1A1K1.
			(7) Connect ME-26(*)/U to pin 3 of connector 1A1XA8A and check for 19.5 ± 0.5 volts dc. If voltage is present, translator module 1A8 is defective. If not present, check for continuity to ground. If there is continuity, relay 1A1K1 is defective. If there is no continuity, there is defect on wiring to contact 10 of relay 1A1K1.
			(8) Replace translator module 1A8, remove receiver IF module 1A7 (para 2-17b), and check for signal (1.75 MHz ± 2 kHz) at connector 1A1XA7-A2 (approx 20 mv) with AN/URM-145. If present, receiver IF module 1A7 is defective. If not present, check wiring between connectors 1A1XA7-A2 and 1A1XA8A-A3 for defects. If no defect is found, translator module 1A8 is defective.
			(9) Connect ME-30(*)/U to high side of AUDIO GAIN control 1A1R2 and check for audio signal (approx 750 mv). If present, proceed to (14) below. If not present, proceed to (10) below.

Table 2-4. Troubleshooting RT-662/GRC or RT-834/GRC—Continued

Item	Indication	Probable trouble	Procedure
			<p>(10) Remove receiver IF module 1A7 (para 2-17b). Check continuity between high side of AUDIO GAIN control 1A1R2 and pin 30 of connector 1A1XA7. If there is continuity, proceed to (11) below. If there is no continuity, wiring is defective.</p> <p>(11) Check for 19.5 ±0.5 volts dc at pin 1 of connector 1A1XA7. If present, proceed to (12) below. If not present, the wiring between pin 1 of connector 1A1XA7, and terminal 1A1E45 is defective.</p> <p>(12) Connect ME-26(*)/U to pin 9 of connector 1A1XA7 and check for 19.5 ±0.5 volts dc. If voltage is present, relay 1A1K1 is defective. If not present, check for continuity to ground. If there is continuity, proceed to (13) below. If there is no continuity, there is a defect in wiring to contact 12 of relay 1A1K1.</p> <p>(13) Connect ME-26(*)/U to pin 2 of connector 1A1XA7 and check for 19.5 ±0.5 volts dc. If voltage is present, receiver IF module 1A7 is defective. If not present, check for continuity to ground. If there is continuity, relay 1A1K1 is defective. If there is no continuity, there is defect in wiring to contact 10 of relay 1A1K1.</p> <p>(14) Replace receiver IF module 1A7, remove receiver audio module 1A10 and check for signal (2 kHz) at pin 12 of connector 1A1XA10 (approx 750 mv) with ME-30(*)/U. If present, proceed to (15) below. If not present, wiring between pin 12 of connector 1A1XA10 and AUDIO GAIN control 1A1R2, or AUDIO GAIN control 1A1R2 is defective.</p> <p>(15) Check for 20 volts dc at pin 7 of connector 1A1XA10. If present, receiver audio module 1A10 is defective. If not present, wiring between pin 7 of connector 1A1XA10 and terminal 1A1E45 is defective.</p>
13	Fuse 1A1F1 blows when RT-662/GRC or RT-834/GRC is keyed.	Defective relay 1A1K1, 1A1K3, 1A1K4, or 1A1A10K1.	Check for shorted coil in relay 1A1K1, 1A1K3, 1A1K4, or 1A1A10K1 (fig. 4-32).

NOTE

To isolate defective keying functions, attempt to key the unit in the order prescribed in items 14 through 23 below.

14	Unit is not keyed with SERVICE SELECTOR switch at SSB/NSK or AM, vox switch at PUSH TO TALK, and H-33(*)/PT push-to-talk switch depressed.	Defective inductor 1A1A2L5, feedthrough capacitor 1A1A5C46, SERVICE SELECTOR switch 1A1S4, vox switch 1A1S1, transmitter IF and audio module 1A5, or wiring.	Remove transmitter IF and audio module 1A5 (para 2-17b) and check for continuity between pin F of AUDIO connector 1A1J18 or 1A1J19 pin 29 of connector 1A1XA5. If there is continuity, transmitter IF audio module 1A5 is defective. If there is no continuity, check following path for continuity, starting with pin F of AUDIO connector 1A1J18 or 1A1J19 (an open indicates the defect): terminal 1A1A2E12 (fig. 2-28); terminal 1A1E5, feed-through Capacitor 1A1A5C46; contact 8, section 3, front of switch 1A1S4; contact 8, rear of switch 1A1S1; contact 6, rear of switch 1A1S1; contact 10, section 1, rear of switch 1A1S4; contact 11, section 1, rear of switch 1A1S4; contact 10, section 3, front of switch 1A1S4; and pin 29 of connector 1A1XA5.
15	On-half second hang time is present after	Defective transmitter IF and audio module 1A5, vox switch 1A1S1, diode	Remove transmitter IF and audio module 1A5 and check for continuity between pins 29 and 27 of connector 1A1XA5. If there is continuity, transmitter IF and audio

Table 2-4. Troubleshooting RT-662/GRC or RT-834/GRC—Continued

Item	Indication	Probable trouble	Procedure
	H-33(*)/PT push-to-talk switch is released with SERVICE SELECTOR switch at SSB/NSK or AM and vox switch at PUSH TO TALK.	1A1CR5, or wiring.	module 1A5 is defective. If there is no continuity, isolate defect by checking following path for continuity, starting with the OHMS lead of ME-26(*)/U connected to pin 27 of connector 1A1XA5 (an open indicates the defect): contact 3, front of switch 1A1S1, contact 11, front of switch 1A1S1; anode of diode 1A1CR5; contact 6, rear of switch 1A1S1.
16	Unit is not keyed when speaking into H-33(*)/PT microphone with SERVICE SELECTOR switch at SSB/NSK, vox switch at PUSH TO VOX, and H-33(*)/PT push-to-talk switch depressed.	Defective SERVICE SELECTOR switch 1A1S4, vox switch 1A1S1, transmitter IF and audio module 1A5, or wiring.	Remove transmitter IF and audio module 1A5 and check continuity between pin F of AUDIO connector 1A1J18 or 1A1J19 and pin 27 of connector 1A1XA5. If there is continuity, transmitter IF and audio module 1A5 is defective. If there is no continuity, isolate defect by checking following path (an open indicates defect): contact 9, section 3, front of switch 1A1S4; contact 5, front of switch 1A1S1, contact 3, front of switch 1A1S1; pin 27 of connector 1A1XA5.
17	Unit is not keyed when speaking into H-33(*)/PT microphone with SERVICE SELECTOR switch at AM, vox switch at PUSH TO VOX, and H-33/PT push-to-talk switch depressed.	Defective SERVICE SELECTOR switch 1A1S4.	Contact 11 of switch 1A1S4 or jumper to contact of switch 1A1S4 is defective.
18	One-half second hang time is present after H-33(*)/PT push-to-talk switch is released with SERVICE SELECTOR switch at SSB/NSK or AM and vox switch at PUSH TO VOX.	Defective diode 1A1CR6 or vox switch 1A1S1.	Check diode 1A1CR6 and contact 10, rear of switch 1A1S1.
19	Unit is not keyed when speaking into H-33(*)/PT microphone with SERVICE SELECTOR switch at SSB/NSK or AM and vox switch at VOX.	Defective SERVICE SELECTOR switch 1A1S4, vox switch 1A1S1, or wiring.	Check following path for continuity to ground (an open indicates the defect): contact 11, section 2, rear of switch 1A1S4; contact 12, section 2, rear of switch 1A1S4; and contact 7, front of switch 1A1S1.

Table 2-4. Troubleshooting RT-662/GRC or RT-834/GRC—Continued

Item	Indication	Probable trouble	Procedure
20	RT-662/GRC or RT-834/GRC does not remain keyed for one-half second after completion of transmission with SERVICE SELECTOR switch at SSB/NSK or am and vox switch at VOX.	Defective transmitter IF and audio module 1A5.	Replace transmitter IF and audio module 1A5.
21	Unit is not keyed with SERVICE SELECTOR switch at FSK.	Defective SERVICE SELECTOR switch 1A1S4, or wiring.	Check section 3, front of switch 1A1S4.
22	Unit is not keyed when KY-116/U is depressed with SERVICE SELECTOR switch at CW.	Defective SERVICE SELECTOR switch 1A1S4, or wiring.	Remove transmitter IF and audio module 1A5 (para 2-17b) and check for continuity between pin 30 of connector 1A1XA5 and pin F of AUDIO connector 1A1J18 or 1A1J19. If there is continuity, transmitter IF and audio module 1A5 is defective. If there is no continuity, check contact 12, section 3, front of switch 1A1S4 and interconnecting wiring to pin 30 of connector 1A1XA5 to isolate defect.
23	Unit does not remain keyed for one-half second after completion of transmission with SERVICE SELECTOR switch set at CW.	Defective transmitter IF and audio module 1A5.	Replace transmitter IF and audio module 1A5.
24	No transmit, but receive operation.	a. Defective relay 1A1K1, wiring, or transmit IF and audio module 1A5.	<ol style="list-style-type: none"> <li data-bbox="767 1181 1385 1356">(1) Set SERVICE SELECTOR switch at CW. Depress H-33(*)/PT push-to-talk switch. Cw sidetone should be heard in H-33(*)/PT earpiece. If heard, proceed to <i>c</i> below. If no tone or receiver noise is present, proceed to <i>b</i> below. If the tone is not present, but receiver noise can be heard, proceed to (2) below. <li data-bbox="767 1376 1385 1524">(2) Remove transmitter IF and audio module 1A5 (para 2-17b). Jumper pin 31 of connector 1A1XA5 to ground. Receiver noise should no longer be heard in the H-33(*)/PT. If there is no receiver noise, proceed to (4) below. If receiver noise is still present, proceed to (3) below. <li data-bbox="767 1544 1385 1699">(3) Remove jumper and check for 23 to 29 volts dc at pin 31 of connector 1A1XA5. If present, relay 1A1K1 or 27 volts dc supply to pin 4 of relay 1A1K1 is defective. If not present, wiring between pin 31 of connector 1A1XA5 and pin 41 of relay 1A1K1 is defective. <li data-bbox="767 1719 1385 1886">(4) Remove jumper from pin 31 of connector 1A1XA5. Connect ME-26(*)/U to pin 2 of connector 1A1XA5 and check for continuity to ground. If there is no continuity, proceed to (5) below. If there is continuity, the wiring between pin 2 of connector 1A1XA5 and contact 12 of relay 1A1K1 is defective.

Table 2-4. Troubleshooting RT-662/GRC or RT-834/GRC—Continued

Item	Indication	Probable trouble	Procedure
			(5) Connect ME-26(*)/U to pin 24 of connector 1A1XA5 and check for 19.5 ± 0.5 volts dc. If present, transmitter IF and audio module 1A5 is defective. If not present, wiring between pin 24 of connector 1A1XA5 and contact 10 of relay 1A1K1 is defective.
	b. Defective receiver IF module 1A7 transmitter IF and audio module 1A5, or wiring.		(1) Remove transmitter IF and audio module 1A5 and receiver IF module 1A7. Check wiring between pin 3 of connector 1A1XA7 and pin 19 of connector 1A1XA5 for defects. If no defect is found, proceed to (2) below. (2) Replace transmitter IF and audio module 1A5 into chassis. Depress and hold H-33(*)/PT push-to-talk switch. With ME-30(*)/U, check for audio signal at pin 3 (approx 150 mv) of connector 1A1XA7. If signal is present, receiver IF module 1A7 is defective. If signal is not present, transmitter IF and audio module 1A5 is defective.
	c. Defective translator module 1A8, transmitter IF and audio module 1A5, relay 1A1K3, relay 1A1K4, or wiring.		(1) Depress and hold H-33(*)/PT push-to-talk switch. Connect AN/URM-145 to XMTR OUPPT test point on top of translator module 1A8 and check for signal level of approximately 5 mv. If present, proceed to (5) below. If not present, proceed to (2) below. (2) Connect AN/URM-145 to XMTR IF OUTPUT test point on top of transmitter IF and audio module 1A5, depress H-33(*)/PT push-to-talk switch, and check for 30 ± 10 mv level. If present, proceed to (4) below. If not present, proceed to (3) below. (3) Place SERVICE SELECTOR switch at CW. Remove transmitter IF and audio module 1A5. Connect an extender cable between connectors 1A1XA5 and 1A5J1. Depress H-33(*)/PT push-to-talk switch and check for input signal (1.752 MHz) at connector 1A1XA5-A3 (in the module at 1A5A1E2) (approx 8 mv). If signal is present, transmitter IF and audio module 1A5 is defective. If not present, check wiring between connectors 1A1XA5-A3 and 1A1XA7-A1. No continuity, wiring between connectors is defective. If no defect is found, 1A7 module is defective. (4) Replace transmitter IF and audio module 1A5 and remove translator module 1A8. Depress H-33(*)/PT push-to-talk switch and check for input signal (1.752 MHz) at connector 1A1XA8A-A2 (approx 30 mv). If present, translator module 1A8 is defective. If not present, check wiring between connectors 1A1XA8A-A2 and 1A1XA5-A1 for defects. If no defect is found, transmitter IF and audio module 1A5 is defective. (5) Connect ME-26(*)/U to RF OUTPUT test point on top of rf amplifier module 1A12 and check for level greater than 5 volts ac. If present, proceed to (7) below. If not present, proceed to (6) below. (6) Check for 27 volts dc at pin 2 of relay 1A1K3. If not present, wiring to terminal 1A1E48 is defective. If present, check for dc level of not more than 2.5 volts (with H-33(*)/PT push-to-talk switch depressed) at pin 1 of relay 1A1K3. Voltage not present, 1A1K3 is defective. If level at 27 volts dc, wiring to terminal 1A1E8 is defective. DC level of not more than 2.5 volts at pin 1 of

Table 2-4. Troubleshooting RT-662/GRC or RT-834/GRC—Continued

Item	Indication	Probable trouble	Procedure
			<p>relay 1A1K3, check continuity between connectors 1A1XA8B-A4 and 1A1XA12-A3. No continuity, relay 1A1K3 is defective.</p> <p>(7) Check for 27 volts dc at terminal 2 of relay 1A1K4. If not present, wiring from terminal 2 of relay 1A1K4 to terminal 1A1E48 is defective. If present, check for dc level of not more than 2.5 volts at pin 1 of relay 1A1K4. If this dc level is not present, wiring from terminal 1 of relay 1A1K4 to terminal 1A1E8 is defective. If level is present, there is defect in wiring between connectors 1A1XA12-A1 and 1A1J21, or relay 1A1K4 is defective.</p>
25	No signal level meter indication during transmit when operated in system or alone.	Defective receiver IF module 1A7.	Replace receiver IF module 1A7.
26	Signal level meter does not indicate when the unit is operated alone in transmit.	Defective internal alc assembly 1A1A5, agc/alc switch 1A1S11, or wiring.	<p>(1) Check for 19.5 ± 0.5 volts dc at contact 2 of agc/alc switch 1A1S11. If present, proceed to (2) below. If not present, wiring between contact 2 of agc/alc 1A1S11 (fig. 2-42) and emitter of transistor 1A1Q1 is defective.</p> <p>(2) Check for 19.5 ± 0.5 volts dc at contact 1 of agc/alc switch 1A1S11. If present, proceed to (3) below. If not present, agc/alc 1A1S11 is defective.</p> <p>(3) Check for 19.5 ± 0.5 volts dc at terminal 1A1A5E1 (fig. 2-28). If present, proceed to (4) below. If not present, wiring between agc/alc 1A1S11 and terminal 1A1A5E1 is defective.</p> <p>(4) Set SERVICE SELECTOR switch at CW and depress H-33(*)/PT push-to-talk switch. Check for 2 volts dc at terminal 1A1A5E6 (fig. 2-28). If present, proceed to (5) below. If not present, internal alc assembly 1A1A5 is defective.</p> <p>(5) Remove transmitter IF and audio module 1A5 and check continuity between terminal 1A1A5E6 and pin 6 of connector 1A1XA5. If there is continuity, transmitter IF and audio module is defective. If there is no continuity, wiring is defective.</p>
27	No transmission in cw only.	Defective transmitter IF and audio module 1A5, frequency dividers modules 1A6, or wiring.	<p>(1) Remove transmitter IF and audio module 1A5 and check for presence of 1 kHz pulse at connector 1A1XA5-A4 using AN/USM-281A. If pulse is present, transmitter IF and audio module 1A5 is defective. If not present, proceed to (2) below.</p> <p>(2) Connect AN/USM-281A to 1 kHz PULSE OUPPT test point on top of frequency dividers module 1A6 and check for 1 kHz pulse. If not present, frequency dividers module 1A6 is defective. If present, check wiring between connectors 1A1XA5-A4 and 1A1XA6A-A2 for defects. If no defect is found, frequency dividers module 1A6 is defective.</p>
23	No voice transmissions in ssb or am.	Defective transmitter IF and audio module 1A5, inductor 1A1A2L3, 1A1A2L4, or 1A1A2L7, feedthrough capacitor 1A1C44, 1A1C45, or 1A1C47, capacitor 1A1A2C3, 1A1A2C4, or 1A1A2C7, or wiring.	Depress and hold H-33(*)/PT push-to-talk switch and speak into microphone. Connect ME-30(*)/U to XMTR AUDIO IN test point on top of transmitter IF and audio module 1A5 and note an indication from 20 to 200 mv. If present, transmitter IF and audio module 1A5 is defective. If not present, remove transmitter IF and audio module 1A5 and isolate defect by checking following connections for continuity and shorts to ground: pin 17 of connector 1A1XA5 to pin C of AUDIO

Table 2-4. Troubleshooting RT-662/GRC or RT-834/GRC—Continued

Item	Indication	Probable trouble	Procedure
29	Am transmissions cannot be received by am receivers.	Defective frequency dividers module 1A6, transmitter IF and audio module 1A5, or wiring.	connectors 1A1J18 and 1A1J19, pin 18 of connector 1A1XA5 to pin D of AUDIO connectors 1A1J18 and 1A1J19, pin 16 of connector 1A1XA5 to pin J of AUDIO connectors 1A1J18 and 1A1J19. Remove transmitter IF and audio module 1A5. Set SERVICE SELECTOR switch at AM. Check continuity between pin 9 of connector 1A1XA5 and ground. If there is no continuity, wiring to contact 2, section 2, rear of SERVICE SELECTOR switch 1A1S4 is defective. If there is continuity, check for a signal (1.75 MHz) at connector 1A1XA5-A2 with AN/URM-145. If signal is present, transmitter IF and audio module 1A5 is defective. If not present, remove frequency dividers module 1A6 (para 2-17b) and check wiring between connectors 1A1XA5-A2 and 1A1XA6B-A2 for defects. If no defect is found, frequency dividers module 1A6 is defective.
30	No cw sidetone	Defective receiver IF module 1A7 or wiring.	Remove receiver IF module 1A7. Set SERVICE SELECTOR switch at CW. Check for 19.5 ± 0.5 volts dc at pin 10 of connector 1A1XA7. If present, receiver IF module 1A7 is defective. If not present, wiring between pin 10 of connector 1A1XA7 and contact 6, section 1, rear of SERVICE SELECTOR switch 1A1S4 is defective.
31	No bfo control of receive cw signals.	Defective receiver IF module 1A7, BFO control 1A1R3, or wiring.	Remove receiver IF module 1A7 and check for 19.5 ± 0.5 volts dc at pins 11 and 12 of connector 1A1XA7. If present, receiver IF module 1A7 is defective. If not present, wiring between pin 11 of connector 1A1XA7 and pin 2 of BFO control 1A1R3, and/or wiring between pin 12 of connector 1A1XA7 and pin 3 of BFO control 1A1R3, or BFO control 1A1R3 is defective.
32	Received signal level cannot be varied with MANUAL RF GAIN control.	Defective resistor 1A1R8, 1A1R12, MANUAL RF GAIN control 1A1R1, wiring or receiver IF module 1A7.	<ol style="list-style-type: none"> (1) Remove receiver IF module 1A7. Set MANUAL RF GAIN control fully counterclockwise. Check at pin 8 of connector 1A1XA7 for level of approximately 2.5 volts dc. If present, receiver IF module 1A7 is defective. If not present, proceed to (2) below. (2) Check for approximately 2.5 volts dc at terminal 2 of MANUAL RF GAIN control 1A1R1. If present, wiring between terminal 2 of MANUAL RF GAIN control 1A1R1 and pin 8 of connector 1A1XA7 is defective. If not present, proceed to (3) below. If 19.5 ± 0.5 volts dc is present, proceed to (3) below. (3) Check dc level at terminal 1 of MANUAL RF GAIN control 1A1R1. If the indication is 19.5 ± 0.5 volts dc, resistor 1A1R8 is defective. If there is no indication, MANUAL RF GAIN control 1A1R1 is defective.
33	Received signals distorted.	Defective MHz synthesizer module 1A9, frequency standard module 1A3, 10 and 1 kHz synthesizer module 1A4, translator module 1A8, receiver audio module 1A10, receiver IF module 1A7, rf amplifier module 1A12, agc/alc 1A1S11 (fig. 2-42), or wiring.	<ol style="list-style-type: none"> (1) Connect AN/USM-281A to MHz SYNTH OUP T test point on top of MHz synthesizer module 1A9. Check for signal ($15.5 \text{ MHz} \pm 106 \text{ Hz}$) with minimum amplitude of 120 mv peak to peak. If correct, proceed to (2) below. If level is out of tolerance, MHz synthesizer module 1A9 is defective. (2) Connect AN/USM-281A to 7.1 MHz OUP T test point (7.089 MHz in RT-834/GRC) on top of 10 and 1 kHz synthesizer module 1A4. Check for signal ($7.1 \text{ MHz} \pm 400 \text{ Hz}$) (7.089 MHz in RT-834/GRC) at minimum amplitude of 80 mv peak-to-peak. If correct, proceed to (4) below. If out of tolerance, 10 and 1 kHz synthesizer module 1A4 is defective.

Table 2-4. Troubleshooting RT-662/GRC or RT-834/GRC—Continued

Item	Indication	Probable trouble	Procedure
			(3) Connect AN/USM-281A to 1 MHz OUPT test point on top of frequency standard module 1A3. Check for signal (1.0 MHz \pm 10 Hz) at a minimum amplitude of 1.2 volts peak-to-peak. If indications are not present, or are out of tolerance, frequency standard module 1A3 is defective. If indications are correct, check wiring between connectors 1A3XA9-A1 and 1A1XA3B-A1 for defects. If no defect is found, frequency standard module 1A3 is defective.
			(4) Connect AN/USM-281A to RF OUTPUT test point on top of RF amplifier module 1A12. Set CN-764/U for 10 mv peak-to-peak indication on AN/USM-281A. Connect AN/USM-281A to RCVR OUPT test point on top of translator module 1A8 and check for signal (1.75 MHz) with a minimum amplitude of 20 mv peak-to-peak. If present, proceed to (5) below. If not present, replace translator module 1A8 with new module. If distortion is still present, replace original module and proceed to (5) below. If distortion is eliminated, original translator module 1A8 was defective.
			(5) Check receiver audio module 1A10 by substitution. If signals still remain distorted, replace original module and proceed to (6) below. If distortion is eliminated, original receiver audio module 1A10 was defective.
			(6) Set CN-764/U for 100 mv level at terminal 1A1A7E6 (fig. 2-28). Check for level between 0 and 3.0 volts dc at IF AGC test point on top of receiver IF module 1A7. If present, proceed to (8) below. If not present, proceed to (7) below.
			(7) Check for 19.5 \pm 0.5 volts dc at contact 2 of agc/alc 1A1S11. If not present, wiring between contact 2 of agc/alc 1A1S11 and terminal 1A1E45 (fig. 2-28) is defective. If present at contact 2, check for 19.5 \pm 0.5 volts dc at contact 1 of agc/alc 1A1S11. If not present at contact 1, agc/alc 1A1S11 is defective. If present, remove receiver IF module 1A7 and check for 19.5 \pm 0.5 volts dc at pin 15 of connector 1A1XA7. If this voltage is present, receiver IF module 1A7 is defective. If not present, wiring between pin 15 of connector 1A1XA7 and contact 1 of agc/alc 1A1S11 is defective.
			(8) Check for level between -1 and -30 volts dc at RF AGC test point on top of receiver IF module 1A7. If present, proceed to (9) below. If not present, receiver IF module 1A7 is defective.
			(9) Check receiver IF module 1A7 by substitution. If signals still remain distorted, replace original module and proceed to (10) below. If distortion was eliminated, original receiver IF module 1A7 was defective.
			(10) Remove rf amplifier module 1A12 (para 2-17f) and check for level between -1 and -30 volts dc at pin 3 of connector 1A1XA12. If present, rf amplifier module 1A12 is defective. If not present, wiring between pin 3 of connector 1A1XA12 and pin 5 of connector 1A1XA7 is defective.

Table 2-4. Troubleshooting RT-662/GRC or RT-834/GRC—Continued

Item	Indication	Probable trouble	Procedure
34	Level of received audio signals fluctuates.	Defective hang and/or age attack time.	Replace receiver IF module 1A7.
35	Receive audio can be heard in LS-166/U, but cannot be heard in H-33(*)/PT or H-227/U.	Defective receiver audio module 1A10, capacitor 1A1A2C1, inductor 1A1A2L1, feedthrough capacitor 1A1C42, or wiring.	<p>(1) Connect H-33(*)/PT to other AUDIO connector. If audio can now be heard, wiring between pin A of AUDIO connectors 1A1J18 and 1A1J19 is defective. If audio still cannot be heard, proceed to (2) below.</p> <p>(2) Connect ME-30(*)/U to 10 MW OUT test point on top of receiver audio module 1A10. Set AUDIO GAIN control maximum and check for 2.45 volt minimum indication on ME-30(*)/U. If present, there is open circuit (wiring, feedthrough capacitor 1A1A5C42, inductor 1A1A2L1) between pin A of AUDIO connectors 1A1J18 and 1A1J19, and pin 14 of connector 1A1XA10. If not present, proceed to (3) below.</p> <p>(3) Remove receiver audio module 1A10 (para 2-17b) and check for short between pin 14 of connector 1A1XA10 and ground. If shorted, feedthrough capacitor 1A1A5C42 or capacitor 1A1A2C1 is defective. If not shorted, receiver audio module 1A10 is defective.</p>
36	Receive audio can be heard in H-33(*)/PT or H-227/U, but cannot be heard in LS-116/U.	Defective receiver audio module 1A10, capacitor 1A1A2C2, inductor 1A1A2L2, feedthrough capacitor 1A1C43, or wiring.	<p>(1) Connect the LS-116/U to other AUDIO connector. If audio can now be heard, the connection between pin L of AUDIO connectors 1A1J18 and 1A1J19 is defective. If audio still cannot be heard, proceed to (2) below.</p> <p>(2) Connect ME-30(*)/U to 2W OUPPT point on top of receiver audio module 1A10. Set AUDIO GAIN control maximum and check for 34.6 volt minimum indication on ME-30(*)/U. If present, there is an open (wiring, feedthrough capacitor 1A1A5C43, or inductor 1A1A2L2) between pin L of AUDIO connectors 1A1J18 and 1A1J19, and pin 15 of connector 1A1XA10. If not present, proceed to (3) below.</p> <p>(3) Remove receiver audio module 1A10 (para 2-17b) and check for a short between pin 15 of connector 1A1XA10 and ground. If shorted, feedthrough capacitor 1A1C43 or capacitor 1A1A2C2 is defective. If not shorted, check for 23 to 29 volts dc at pin 8 of connector 1A1XA10. If present, receiver audio module 1A10 is defective. If not present, wiring between pin 8 of connector 1A1XA10 and contact 4, section 1 front, of SERVICE SELECTOR switch 1A1S4 is defective.</p>
37	Receiver audio will not un-squelch with SQUELCH switch at OFF.	Defective SQUELCH switch 1A1S2, wiring, or receiver audio module 1A10.	<p>(1) Check continuity between contact 6 of switch 1A1S2 and ground. If there is continuity, proceed to (2) below. If there is no continuity, the wiring is defective.</p> <p>(2) Check continuity between contacts 4 and 6 of SQUELCH switch 1A1S2. If there is continuity, proceed to (3) below. If there is no continuity, SQUELCH switch 1A1S2 is defective.</p> <p>(3) Remove receiver audio module 1A10 and check continuity between pin 13 of connector 1A1XA10 and ground. If there is continuity, receiver audio module 1A10 is defective. If there is no continuity, connection between pin 13 of connector 1A1XA10 and contact 4 of SQUELCH switch 1A1S2 is defective.</p>

Table 2-4. Troubleshooting RT-662/GRC or RT-834/GRC—Continued

Item	Indication	Probable trouble	Procedure
38	Receiver audio will not un-squelch with SERVICE SELECTOR switch at CW or FSK.	Defective SERVICE SELECTOR switch 1A1S4, wiring or receiver audio module 1A10.	<ol style="list-style-type: none"> (1) Check for continuity between contact 11, section 2 rear of SERVICE SELECTOR switch 1A1S4 and ground. If there is continuity, proceed to (2) below. If there is no continuity, wiring between contact 11, section 2, rear of switch 1A1S4 and contact 9, section 2, front of switch 1A1S4 and ground is defective. (2) Check for continuity between contacts 11 and 1, section 2, rear of switch 1A1S4. If there is continuity, proceed to (3) below. If there is no continuity, section 2, rear of switch 1A1S4 is defective. (3) Remove receiver audio module 1A10 (para 2-17b) and check continuity between contact 1, section 2, rear of switch 1A1S4 and pin 5 of connector 1A1XA10. If there is continuity, receiver audio module 1A10 is defective. If there is no continuity, wiring is defective.
39	Receiver audio will not un-squelch with SQUELCH switch at ON.	Defective receiver audio module 1A10.	Replace receiver audio module 1A10.
40	Noisy receiver audio signals will not squelch with SQUELCH switch at ON.	Defective receiver audio module 1A10, wiring, transmit-receive relay 1A1K1, or SQUELCH switch 1A1S2.	<ol style="list-style-type: none"> (1) Check for 19.5 ± 0.5 volts dc at contact 14 of transmit-receive relay 1A1K1. If present, proceed to (2) below. If not present, wiring between contact 14 of relay 1A1K1 and the emitter of transistor 1A1Q1 is defective. (2) Check for 19.5 ± 0.5 volts dc at contact 10 of transmit-receive relay 1A1K1. If present, proceed to (3) below. If not present, transmit-receive relay 1A1K1 is defective. (3) Remove receiver audio module 1A10 (para 2-17b) and check for a 19.5 ± 0.5 volts dc at pin 3 of connector 1A1XA10. If present, proceed to (4) below. If not present, wiring between contact 10 of relay 1A1K1 and pin 3 of connector 1A1XA10 is defective. (4) Check continuity to ground between pin 13 of connector 1A1XA10 and ground. If there is continuity, SQUELCH switch 1A1S2 is defective. If there is no continuity, proceed to (5) below. (5) Remove receiver IF module 1A7 and check for continuity between pin 29 of connector 1A1XA7 and pin 6 of connector 1A1XA10. If there is continuity, receiver audio module 1A10 is defective. If there is no continuity, wiring is defective.
41	No, or limited, vernier operation.	Defective thermistor 1A1R18, resistor 1A1R9, FREQ VERNIER potentiometer 1A1R4, FREQ VERNIER switch 1A1S8, wiring, or frequency dividers module 1A6.	<ol style="list-style-type: none"> (1) Check for defective thermistor 1A1R18 or resistor 1A1R9. If both are normal, frequency dividers module 1A6 is defective or requires adjustment (higher category repair required). If there is no vernier operation, proceed to (2) below. (2) Remove frequency dividers module 1A6 (para 2-17b) and check for approximately 19.5 ± 0.5 volts dc at pins 1, 2, and 4, of connector 1A1XA6A. If all indications are present, frequency dividers module 1A6 is defective. If all indications are not present, FREQ VERNIER switch 1A1S8 or associated wiring is defective. If one or two indications are not present, FREQ VERNIER control 1A1R4 or wiring to pins 1, 2, and 4, of connector 1A1XA6A is defective.

Table 2-4. Troubleshooting RT-662/GRC or RT-834/GRC—Continued

Item	Indication	Probable trouble	Procedure
42	Fuse 1AF1 opens for any setting of SERVICE SELECTOR switch.	Defective 27 volt input line.	Check for a shorted Zener diode 1A1VR2, capacitor 1A1C50 or 1A1C51, filter 1A1FL1, and associated wiring (located under panel cover of J20 and J21 connector chassis).
43	Inaccurate tuning code to AM-3349/GRC-106 with an accurate tuning code to turret in rf amplifier module 1A1Z.	<p>a. Defective code line-----</p> <p>b. Defective switch 1A1S6 (section 2, front; section 2, rear, or section 3, front), switch 1A1S5 front, or wiring.</p>	<p>(1) For each code line, check for continuity between associated pin (E, S, U, V, R) of PA CONTROL connector 1A1J20 and its point of termination on switch 1A1S6. If there is continuity in all connections, proceed to (2) below. If an open is found, associated wiring, feedthrough capacitor, or LC filter on printed circuit board 1A1A3 or 1A1A4 is defective.</p> <p>(2) Successively connect ME-26(*)/U between pins E, S, U, V, and R of PA CONTROL connector 1A1J20 (fig. 4-33) and ground. For each connection, rotate MHz controls to several positions and allow unit to tune. If ME-26(*)/U indicates continuity to ground at all frequencies, associated feedthrough capacitor or capacitor on printed circuit board 1A1A3 or 1A1A4 is defective. If ME-26(*)/U indication varies, proceed to b below.</p> <p>Isolate the trouble by visual inspection and by checking connections on switches 1A1S5 and 1A1S6 for opens and shorts.</p>
44	AM-3349/GRC-106 turns off when keyed with the TUNE-OPERATE switch set at OPERATE.	Defective capacitor 1A1A3C2, inductor 1A1A3L2, feedthrough capacitor 1A1C25, resistor 1A1R5, 1A1R6, 1A1R11, 1A1R14 or 1A1R15, wiring, SERVICE SELECTOR switch 1A1S4, or diode 1A1CR7.	Connect 10 volts dc between pin C of PA CONTROL connector 1A1J20 and ground. Remove transmitter IF and audio module 1A5 and check for approximately 10 volts dc at pins 7 and 8 of connector 1A1XA5. If indication is at both pins, transmitter IF and audio module 1A5 is defective. If there is no indication at either pin, capacitor 1A1A3C2, feedthrough capacitor 1A1C25, or interconnecting wiring is defective. If there is no indication at pin 8 only, potentiometer 1A1R15, resistor 1A1R21, or interconnecting wire is defective. If there is no indication at pin 7 only, resistor 1A1R6, 1A1R5, 1A1R11, 1A1R14, wiring, diode 1A1CR7, or section 3, rear of switch 1A1S4 is defective.
45	AM-3349/GRC-106 continues to turn off when TUNE-OPERATE switch is at TUNE.	Defective capacitor 1A1A3C3, inductor 1A1A3L3, feedthrough capacitor 1A1C26, diode 1A1CR8, resistor 1A1R13, or wiring.	Check for continuity between pin B of PA CONTROL connector 1A1J20 and contact 3, rear section 3, S4 to isolate the defective part.
46	No keying information to AM-3349/GRC-106 when RT-662/GRC or RT-834/GRC is keyed.	Defective transmitter IF and audio module 1A5, wiring, feedthrough capacitor 1A1C29, or inductor 1A1A4L6.	Remove transmitter IF and audio module 1A5. Check for continuity between pin 32 of connector 1A1XA5 and pin T of PA CONTROL connector 1A1J20. If connection is open, feedthrough capacitor 1A1C29, wiring, or inductor 1A1A4L6 is defective. If there is no open, transmitter IF and audio module 1A5 is defective.
47	No frequency change information to AM-3349/GRC-106.	Defective MHz switch 1A1S6, 100 kHz switch 1A1S7, feedthrough capacitor 1A1C30, inductor 1A1A3L4, or wiring.	(1) Connect ME-26(*)/U between contact 4, section 1, rear of MHz switch 1A1S6 and ground. Rotate MHz control and check for momentary indications of continuity on ME-26(*)/U. If present, proceed to (2) below. If not present, section 1, rear of MHz switch 1A1S6 is defective.

Table 2-4. Troubleshooting RT-662/GRC or RT-834/GRC—Continued

Item	Indication	Probable trouble	Procedure
			(2) Check wiring between contact 4, section 1, rear of MHz switch 1A1S6 and feedthrough capacitor 1A1C30 for continuity. If present, proceed to (3) below. If not present, wiring is defective. (3) Connect ME-26(*)/U between contact 8, rear of 100 kHz switch 1A1S7 and ground. Rotate 100 kHz control and check for momentary indication of continuity on ME-26(*)/U. If present, proceed to (4) below. If not present, rear section of 100 kHz switch 1A1S7 is defective. (4) Check wiring between contact 8, rear of 100 kHz switch 1A1S7 and feedthrough capacitor 1A1C30 for continuity. If present, proceed to (5) below. If not present, wiring is defective. (5) Check continuity between feedthrough capacitor 1A1C30 and pin H of PA CONTROL connector 1A1J20. If there is no continuity, wiring, feedthrough capacitor 1A1C30, or inductor 1A1A3L4 is defective.
48	No operate information to AM-3349/GRC-106, but standby information is present.	Defective inductor 1A1A4L2, feedthrough capacitor 1A1C23, or wiring.	Check continuity between contact 10, section 2, of SERVICE SELECTOR switch 1A1S4 and pin P of PA CONTROL connector 1A1J20 to determine whether wiring, inductor 1A1A4L2, or feedthrough capacitor 1A1C23 is defective.
49	No standby information to AM-3349/GRC-106, but operate information is present.	Defective inductor 1A1A4L1, feedthrough capacitor 1A1C24, or wiring.	Check continuity between contact 8, section 2, front of SERVICE SELECTOR switch 1A1S4 and pin N of PA CONTROL connector 1A1J20 to determine whether wiring, inductor 1A1A4L1, or feedthrough capacitor 1A1C24 is defective. If shorted, feedthrough capacitor 1A1C24 or capacitor 1A1A4C1 is defective.
50	AM-3349/GRC-106 cannot be shut off from RT-662/GRC or RT-834/GRC.	Shorted operate or standby line.	(1) Check for shorted feedthrough capacitor 1A1C23 or 1A1C24. (2) Check for shorted capacitor 1A1A4C1 or 1A1A4C2 on printed circuit board 1A1A4.
51	No standby or operate information to AM-3349/GRC-106.	Defective SERVICE SELECTOR switch 1A1S4 or wiring.	Check section 2, front of SERVICE SELECTOR switch 1A1S4 and associated wiring between contact 9 and ground.
52	Tune information from AM-3349/GRC-106 does not turn off balanced modulator and reinsert carrier for AM-3349/GRC-106 fine tuning.	Defective inductor 1A1A4L7, feedthrough capacitor 1A1C28, receiver IF module 1A7, transmitter IF and audio module 1A5, or wiring.	Remove receiver IF module 1A7 and transmitter IF and audio module 1A5. Check for continuity between pin M of PA CONTROL connector 1A1J20 and pins 13 of connector 1A1XA7 and 10 of connector 1A1XA5. If there is continuity in both connections, receiver IF module 1A7 or transmitter IF and audio module 1A5 is defective. If there is no continuity, wiring, inductor 1A1A4L7, or feedthrough capacitor 1A1C28 is defective.
53	RT-662/GRC or RT-834/GRC remains in a constant tune condition.	Shorted tune line-----	(1) Check for shorted feedthrough capacitor 1A1C28. (2) Check for shorted capacitor 1A1A4C7.

Section IV. TROUBLESHOOTING 100 Hz SYNTHESIS, RT-834/GRC

2-10. Test Setup

(fig. 2-9)

a. General. Bench tests of the RT-834/GRC require connection to a power source and to various test equipments. The power source must be connected to the RT-834/GRC for all dynamic servicing procedures; the test equipment connections vary from test to test. Remove the RT-834/GRC from its case by loosening the six captive Allen screws and sliding out the chassis. Remove and store the 13 screws and washers that secure the RT-834/GRC bottom cover plate.

b. Power Supply Connections. Connect the PP-4763/GRC to the POWER connector on the RT-834/GRC; use Cable Assembly, Special Purpose, Electrical CX-10071/U.

NOTE

If the PP-4763/GRC is not available, use an equivalent dc power source capable of supplying 27 volts dc at 5 amperes with less than 1 volt rms ripple content.

c. Preliminary Test. Prior to connecting to the RECEIVER IN and FREQ STD connectors, perform the following test:

(1) Set the SERVICE SELECTOR switch at SSB/NSK and allow a 15 minute warmup.

(2) Connect the AN/URM-145 to the FREQ STD connector and check for the presence of a 270 ± 50 mv level. If the indication is not correct, proceed to item 1 of the troubleshooting table 2-5 (para 2-11e).

d. Test Equipment. Connect the test equipment (fig. 2-9) as called out in the particular tests (para 2-11d). Set the MHz and kHz controls at 04998, the SQUELCH switch at OFF,

the FREQ VERNIER control at OFF, and the MANUAL RF GAIN control maximum clockwise, unless otherwise specified.

2-11. Localizing Troubles

a. General. Procedures outlined in table 2-5 to localize troubles to a module, assembly, or chassis part of the RT-834/GRC are supplemental to the procedures of table 2-4. Depending on the nature of the operational symptoms, one or more of the localizing procedures will be necessary.

b. Use of Table. Table 2-5 supplements the operational procedures and troubleshooting information described in TM 11-5820-520-12 and section III of this chapter. If previous operational checks have resulted in reference to a particular item of this table, go directly to the referenced item. If no operational symptoms are known, begin with the monthly preventive maintenance checks and services chart (TM 11-5820-520-12) and proceed until the trouble is located. Before starting a procedure for any given item of the table, verify that any module removed in a previous procedure has been replaced.

c. Parts Identification and Location.

(1) Module locations are shown in figure 2-26.

(2) Identification of pin numbers of modules 1A1XA2 through 1A1XA12 (fig. 2-5) can be made by the removal of the modules and examination of the connector markings.

(3) All terminals, such as 1A1E14, are letter-stamped on the chassis, adjacent to the terminal, for identification purposes (fig. 2-28 and 2-29).

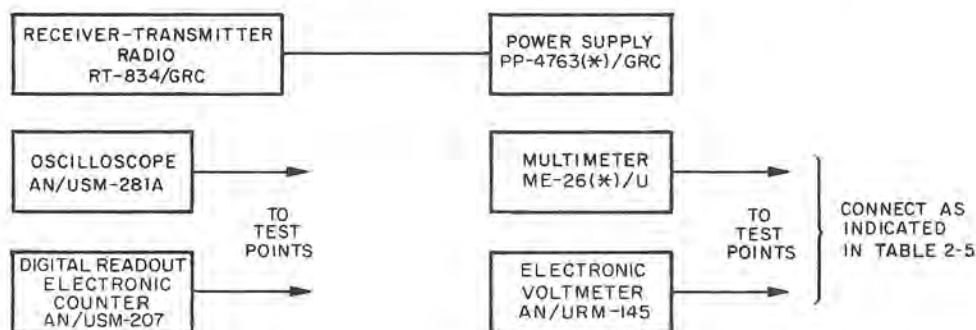

TM 5820-520-35-809

Figure 2-9. Test setup for troubleshooting RT-834/GRC.

(4) To identify and locate a part, not shown in figures 2-5 through 2-8 and 2-25 through 2-30, refer to the complete reference designation (para 2-5) to determine the approximate area of location (fig. 2-25, 2-27, and 2-30). Each part is identified by letter-stamping on the chassis or printed board at its location.

d. Conditions for Test. Expect for resistance measurements and continuity checks, all checks in the table are to be conducted with the RT-834/GRC connected to a power source as described in paragraph 2-10. Before performing the procedures outlined in the table, turn on all test equipment and allow a 10-minute warmup

period. Turn the RT-834/GRC SERVICE SELECTOR switch to STANDBY and allow a 15-minute warmup period. After the warmup period is completed, set the SERVICE SELECTOR switch at SSB/NSK and adjust the CN-764/U for a 1-mv input level at the RECEIVER IN connector. To check or test components mounted on the bottom of the chassis, remove the bottom plate (para 2-10a).

CAUTION

Before making any resistance measurements or continuity checks in the procedures of the table, make sure that no power is applied to the RT-834/GRC.

Table 2-5. Troubleshooting 100 Hz Synthesis, RT-834/GRC

<i>Item</i>	<i>Indication</i>	<i>Probable trouble</i>	<i>Procedure</i>
1	No transmit or no receive.	Defective 100 Hz synthesizer module 1A1A2A8.	<p>(1) Connect the AN/USM-281A to the 7.089 MHz OUPPT test point on top of 10 and 1 kHz synthesizer module 1A4. Connect the AN/USM-207 to the AN/USM-281A VERT SIG OUT connector. The AN/USM-207 should indicate 7.089 MHz \pm400 Hz signal. Also, check for a level of 35 \pm5 mv with the AN/URM-145. If the indications are correct, proceed to (3) below. If the level of the 7.089 MHz signal is out of tolerance go to (2) below.</p> <p>(2) Connect AN/USM-281A to 1 kHz PULSE OUT test point on top of frequency divider module 1A6. Check for a pulse, 1 volt peak-to-peak min. pulse width 4.0 \pm1 μsec at 50% amplitude and a prr of 1 msec. If indication is incorrect frequency divider module 1A6 is defective. If indication is correct check the connection from 1A1XA46A-A1 to 1A1A2A8A1J1 and from 1A1A2A8A1J2 to 1A1XA4A-A2 (fig. 2-5). If connection is found to be in order, 10 and 1 kHz synthesizer module 1A4 is defective.</p> <p>(3) Check for 35 \pm5 mv at 1A1A2A8A2J1 (fig. 4-34) using AN/URM-145. If the indication is correct proceed to (4) below. If the level of the 7.089 MHz signal is out of tolerance, check the connection between 1A1XA4B-A1 and 1A1A2A8A2J2 for defects. If a defect is found make necessary repair.</p> <p>(4) Remove the 100 kHz synthesizer module (1A2) and check for the presence of 7.100 MHz \pm400 Hz at 1A1XA2-A2 (100 Hz frequency selection switch in "0" position) using AN/USM-281A and connect AN/USM-207 to the AN/USM-281A VERT SIG OUT connector. Also check for a level of 35 \pm10 mv using AN/URM-145. If indications are correct, the 100 kHz synthesizer is defective. If indications are out of tolerance proceed to (5) below.</p> <p>(5) Check the connection between connectors 1A1A2A8A2J2 and 1A1XA2-A2 for defects. If a defect, is found, make necessary repairs. If no defect is found proceed to (6) below.</p>

Table 2-5. Troubleshooting 100 Hz Synthesis, RT-834/GRC—Continued

Item	Indication	Probable trouble	Procedure
			(6) Remove connector 1XA1A8 and check for 19.5 \pm 2 vdc at pin 6 using ME-26(*)/U. If level is correct, proceed to (7) below. If indication is not correct, the wiring between pin 6 of 1XA1A8 and 1A1E45 is defective.
			(7) Check pin 2 of 1XA1A8 for 5.0 \pm 0.5 vdc using ME-26(*)/U. If indication is correct the 100 Hz synthesizer module is defective. If indication is not correct go to (8) below.
			(8) Check terminal E1 on voltage regulator 1A1A2A9 (fig. 4-48) for 5.0 \pm 0.5 vdc using ME-26(*)/U. If indication is incorrect proceed to (9) below. If indication is correct check wiring between 1A1A2A9E1 and 1XA1A8-2.
			(9) Check for 18 \pm 2 vpp, 5 kHz square wave on terminal E3 of voltage regulator 1A1A2A9 with AN/USM-281A. If indication is correct, voltage regulator 1A1A2A9 is defective. If indication is not correct, check wiring between E3 of 1A1A2A9 and 1A1XA11-2.

Section V. TROUBLESHOOTING AMPLIFIER, RADIO FREQUENCY AM-3349/GRC-106

CAUTION

1. Do not attempt removal or replacement of assemblies in the AM-3349/GRC-106 without reading the procedures in sections VI.
2. Do not operate Amplifier, Radio Frequency AM-3349/GRC-106 with the cover removed from antenna coupler assembly 2A3. Proper air circulation within the unit is dependent on this cover being in place.

2-12. Test Setup

(fig. 2-10)

Bench tests of the AM-3349/GRC-106 require connection to a power source, the RT-662/GRC or RT-834/GRC, and to various test equipments. The power source must be connected to the RT-662/GRC or RT-834/GRC and the AM-3349/GRC-106 for all dynamic servicing procedures; the test equipment connections vary from test to test. Remove the AM-3349/GRC-106 chassis from its case by loosening the six captive Allen screws and sliding out the chassis. Set the AM-3349/GRC-106 chassis on top of the RT-662/GRC or RT-834/GRC.

a. Power Supply Connections. Connect the PP-4763/GRC to the POWER connector on the RT-662/GRC or RT-834/GRC and to the PRIM. POWER connector on the AM-3349/GRC-106 using the CX-10071/U's. Connect the correct test cable between case connector 2A6XA1 (inside right rear of case) and chassis connector 2A1J1 (on back of chassis) (fig. 2-3), or disconnect case connector 2A6XA1 from

the case by removing the two screws, and connecting case connector 2A6XA1 and cable to chassis connector 2A1J1.

NOTE

If Power Supply PP-4763/GRC is not available, use an equivalent dc power source capable of supplying 27 volts dc at 50 amperes with less than 1 volt rms ripple content.

b. Test Equipment. Interconnect the RT-662/GRC or RT-834/GRC and the AM-3349/GRC-106 as shown in figure 2-10 and as specified in the tests of paragraph 2-13.

2-13. Localizing Troubles

a. General. Procedures are outlined in table 2-6 to localize troubles to an assembly or part of the AM-3349/GRC-106. Depending on the nature of the operational symptoms, one or more of the localizing procedures will be necessary. Part locations are shown in figures 2-11 through 2-24, and 2-31 through 2-37. For parts not shown, make use of complete reference designation (para 2-4) to determine approximate

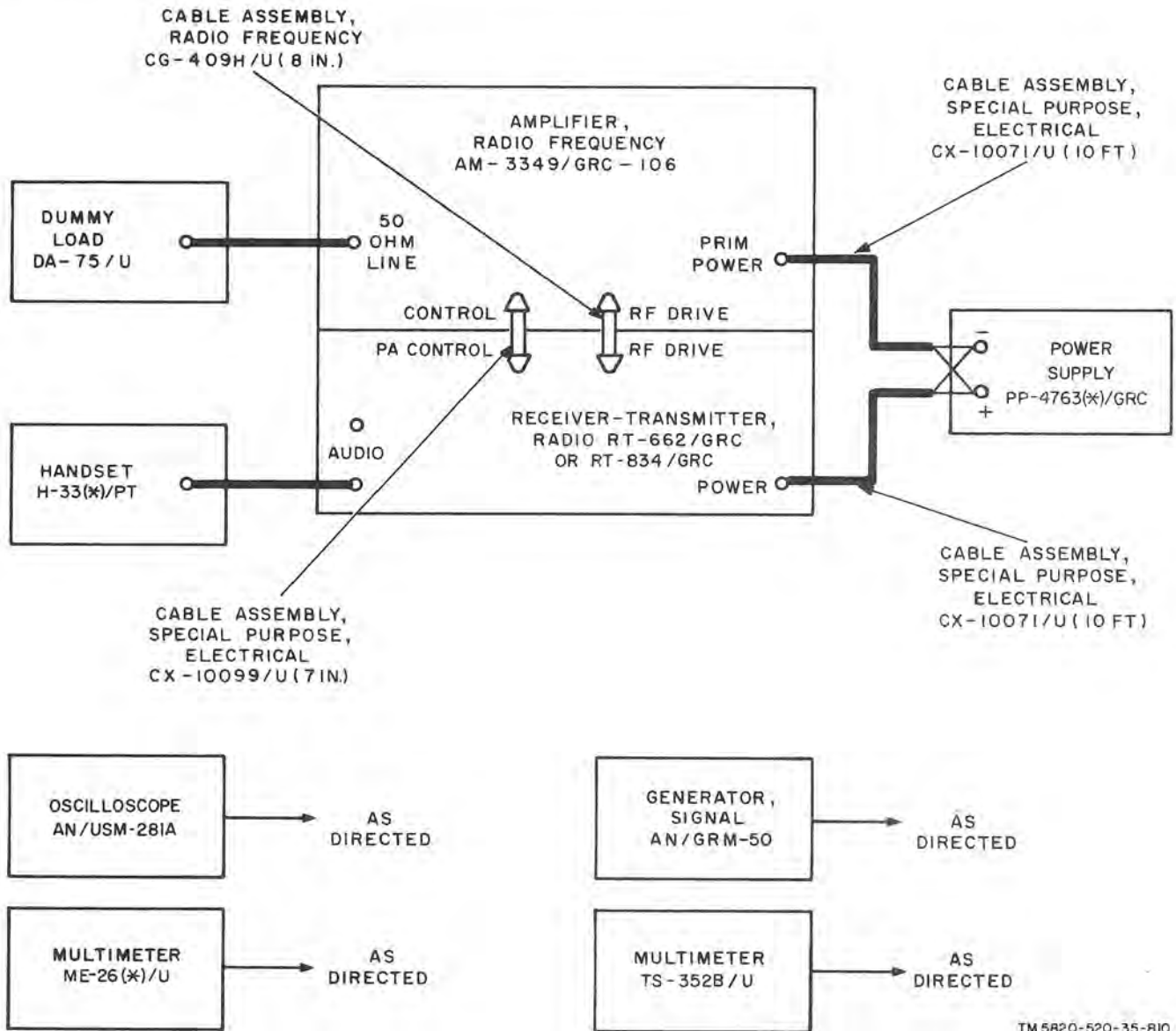

TM 5820-520-35-810

Figure 2-10. Test setup for troubleshooting AM-3349/GRC-106.

area of location (fig. 2-29 and 2-31). Each part is identified by letter-stamping on the chassis or printed board at its locations.

b. *Use of the Table.* Table 2-6 is designed to supplement the operational procedures and troubleshooting information described in TM 11-5820-520-12. If no operational symptoms are known, begin with the monthly preventive maintenance checks and services table in TM 11-5820-520-12, and proceed until the trouble is located.

c. *Conditions for Test.*

(1) The repairman must be familiar with the assembly removal and replacement procedures in paragraphs 2-19 through 2-24 prior to troubleshooting the AM-3349/GRC-106. When dynamic troubleshooting reveals a symptom described in the indication column of table 2-6 the symptom must be checked in an effort to locate the fault, by turning the AN/GRC-106(*) power off, grounding the parts cited in the WARNING below with a shorting stick, and then disassemble the AM-3349/GRC-106 as far as necessary to perform the instructions in the procedure column of table 2-6.

(2) All checks in the table are to be conducted with the RT-662/GRC or RT-834/GRC and AM-3349/GRC-106 connected to a power source as described in paragraph 2-12. Before performing the procedures in the table turn on the test equipment and allow a 15-minute warmup period. After the warmup period is completed, proceed as instructed in TM 11-5820-520-12.

WARNING

Voltages up to 3,000 volts dc exist in the AM-3349/GRC-106. Before removing assemblies or making resistance measurements or continuity checks in

the procedures of the table, set the SERVICE SELECTOR and PRIM. PWR. switches at OFF, and disconnect the CX-10071/U cable from the PRIM. POWER connector. Before touching any components, always use a shorting stick to ground capacitors 2A5A2C4 and 2A5A2C5 (fig. 2-33) and pin A or B of PRIM. POWER connector 2A5J7.

CAUTION

When operating the AM-3349/GRC-106 out of the case, direct a stream of air onto the AM-3349/GRC-106 for cooling.

Table 2-6. Troubleshooting AM-3349/GRC-106

Item	Indication	Probable trouble	Procedure
1	PRIM. PWR. circuit breaker trips repeatedly with SERVICE SELECTOR switch set at OFF.	Primary power line shorted to ground.	Check wiring common to pin 2 of relay 2A5A2K1 for shorts to ground (fig. 4-53).
2	PRIM. PWR. circuit breaker trips repeatedly with SERVICE SELECTOR switch by STAND BY or any operate position before the 60 second delay has elapsed.	Defective standby 27 volt line.	(1) Referring to figures 4-49 through 4-55, check all wiring and the following components common to pin 3 of relay 2A5A2K1 (fig. 2-34) for shorts to ground: 2A1A1A2, 2A1A2, 2A5A2C1, 2A5A2C2, 2A5A2C3, 2A1A2C16 (fig. 2-18), 2A1A1C17, 2A6A1C2 (fig. 2-17), 2A6A1C3, 2A5A7C8, 2A4A3C5, 2A6A1Q1, or 2A6A1Q2, 2A6A1T1, 2A5Q1 (fig. 4-53), 2A5A2Q2 (fig. 2-33) and 2A5A2T1. (2) If fault is 2A5Q1 (fig. 2-34) or 2A5A2Q2, insure that dc-to-dc converter can be shut off by shorting terminal 2A5A3E1 (fig. 2-20) to ground. (3) If converter does not shut off, set PRIM. PWR. circuit breaker at off, and check for short to ground at terminals 2A5A3E12, 2A5A3E9, and 2A5A3E14. Also, check for continuity between feedthrough capacitors 2A5A7C6 (fig. 2-35) and 2A5A7C4 and between pin 3 of relay 2A5A2K1 and 2A5A7C2 (approximately 200 ohms). If no short or open is found, replace 2A5A7. If short or open is found, isolate fault by checking wiring and components associated with point of check at which abnormal condition is obtained.
3	Blowers fail to energize with SERVICE SELECTOR switch at STAND BY. Set then turns off.	a. Defective standby circuit.	(1) Check for 27 volts dc at terminal 2A6A1E4 (fig. 4-54). If indication is correct, proceed to b below. (2) If indication in (1) above is incorrect, check for continuity between pin N of CONTROL connector 2A5J2 (fig. 2-6) and pin 1 of relay 2A5A2K1 (fig. 2-33). If continuity does not exist, trace ground line to locate open circuit. (3) Check continuity between pin 3 of relay 2A5A2K1 and pin 6 of connector 2A1A1XA7 (fig. 2-25 and 4-49). If continuity does not exist, trace this line to locate open circuit.

Table 2-6. Troubleshooting AM-3349/GRC-106—Continued

Item	Indication	Probable trouble	Procedure
		b. Defective dc-to-dc inverter assembly 2A6A1.	<ul style="list-style-type: none"> (4) Check relay assembly 2A7 (fig. 2-31) by substitution. (5) Check diode 2A5A2CR1 (fig. 4-53). (6) Check for 27 volts dc at pins 4, 3, and 2 of relay 2A5A2K1. If 27 volts dc is present at pins 4 and 2 but not at pin 3, replace relay. If 27 volts dc is not present at pin 2, repair wiring between PRIM. PWR. circuit breaker and pin 2. (1) Jumper terminal E1 to E4 of blower protection board 2A1A2 (fig. 2-41). If blowers operate normally, blower switch 2A1S1 is defective. If blowers do not operate, blower protection circuit assembly 2A1A2 is defective. (2) Check all components of blower protection circuit assembly 2A1A2. Replace assembly if a part is defective. (3) Using TS-352B/U, check for 141 ± 14 volts ac between 2A6A1E13 (fig. 2-17) and for 66 ± 10 volts ac between terminals 2A6A1E9 and 2A6A1E11 (fig. 4-54). If indications are correct, check all wiring common to transformer 2A6A1T1. (4) If neither indication in (1) above is correct, check all windings of transformer 2A6A1T1. If any are open, replace dc-to-dc inverter assembly 2A6A1. (5) If no transformer defect is found, see figure 4-54 and check all dc-to-dc inverter assembly 2A6A1 components and wiring. Replace if necessary.
4	Blowers deenergize after initial start period with SERVICE SELECTOR switch at STANDBY.	Defective blower protection circuit.	Perform procedures of item 3a to isolate malfunction.
5	PRIM. PWR. circuit breaker trips repeatedly with SERVICE SELECTOR switch at any operate position after the 60-second delay has elapsed.	Defective operate 27 volt line.	Check all wiring and components common to pin 6 of relay 2A7K5 (fig. 3-62). Check relay assembly 2A7 by substitution.
6	Blower motor 2A6B1 does not energize with SERVICE SELECTOR switch at STANDBY or any operate position.	Defective blower motor or dc-to-ac inverter assembly 2A6A1.	<ul style="list-style-type: none"> (1) First check blower fan to insure that it is not binding; then, using TS-352B/U, check for 66 ± 10 volts ac across blower motor. If indication is incorrect, proceed to (3) below. (2) If voltage at blower motor is correct, check capacitor 2A6C1 (fig. 4-54). If capacitor is good, replace blower motor 2A6B1 (fig. 4-49). (3) If voltage at blower motor is incorrect, refer to item 3b above to isolate malfunction.
7	Blower motor 2A1B1 does not energize with SERVICE SELECTOR switch at STANDBY or any operate position.	Defective blower motor 2A1B1 or dc-to-ac inverter assembly 2A6A1, or defective blower protection circuit 2A1A2 (fig. 2-40).	<ul style="list-style-type: none"> (1) First check blower fan to insure that it is not binding; then using TS-352B/U, check for 141 ± 14 volts ac at BLOWER VOLTAGE test points 2A1J9 and 2A1J10 (fig. 4-49). If indication is incorrect, proceed to (3) below. (2) If voltage at test points is correct, check capacitor 2A1C1 (fig. 4-49). If capacitor is good, replace blower motor. (3) If voltage at BLOWER VOLTAGE test points is incorrect, refer to item 3b above to isolate malfunction.

Table 2-6. Troubleshooting AM-3349/GRC-106—Continued

Item	Indication	Probable trouble	Procedure
8	No indication or incorrect indication on TEST METER with TEST METER switch at PRIM. VOL. and SERVICE SELECTOR switch at any operate position.	<p>a. Defective wiring in 27 volt operate line or operate ground line.</p> <p>b. Defective relay 2A7K4 or 2A7K5.</p> <p>c. Defective metering circuits.</p> <p>d. Defective resistor 2A5A5R2.</p> <p>e. Defective capacitor 2A5C4.</p> <p>f. Defective meter 2A5M1.</p>	<p>(1) Check for continuity between terminal 2A5A5E18 (fig. 4-53) and pin 15 of connector 2A1AXA7.</p> <p>(2) Check for continuity between pin P of CONTROL connector 2A5J2 (fig. 2-6) and pin 10 of chassis connector 2A1A1XA7 (fig. 2-7). If continuity does not exist, check wiring, inductor 2A5A1A2L4 (fig. 2-22), and feedthrough capacitor 2A5A1C11 for opens.</p> <p>Check by substitution and repeating procedure (a above) (fig. 3-62).</p> <p>Check continuity between negative meter terminal and chassis ground and between positive meter terminal and terminal 2A5A5E19 (fig. 2-16 and 4-53). If either indication is incorrect, check wiring and associated switch section.</p> <p>Check for $523K \pm 25K$ ohms between terminals 2A5A5E18 and 2A5A5E19 (fig. 2-16 and 4-53). If indication is incorrect, replace terminal board 2A5A5.</p> <p>Check capacitor 2A5C4 (fig. 2-33) for short.</p> <p>Remove relay assembly 2A7 and apply 27 volts dc between terminal 2A5A5E18 (+) and chassis ground (-). If meter 2A5M1 (fig. 2-33) fails to indicate, replace meter.</p>
9	No indication or incorrect indication on TEST METER with SERVICE SELECTOR switch at any operate position, TEST METER switch set at LOW VOLT, and TUNE-OPERATE switch at TUNE.	<p>a. Defective low voltage power supply.</p> <p>b. Defective metering circuit.</p>	<p>(1) Check for 500 \pm 30 volts dc at L.V. test point 2A1J9 (fig. 4-49) and for 24 \pm 2 volts dc at H.V. test point 2A1A1J10. If both indications are correct, proceed to b below. If both indications are incorrect, proceed to item 10. If indication at L.V. test point is incorrect, but indication at H.V. test point is correct proceed to (2) below.</p> <p>(2) Using TS-352B/U, check for 550 \pm 50 volts ac between pins 6 and 7 of transformer 2A5A2T1 and between terminals 2A5A4E4 and 2A5A4E5 (fig. 2-13). If voltages at transformer and terminals are both correct, proceed to (3) below.</p> <p>(3) Check to see that terminal 2A5A4E3 is grounded.</p> <p>(4) Check for 500 volts dc at terminal 2A5A4E2. If indication is incorrect, check components of board 2A5A4 (fig. 2-13).</p> <p>(1) Check continuity between negative side of meter 2A5M1 and ground. If there is no continuity, section A of switch 2A5S2 or associated wiring is defective.</p> <p>(2) Check continuity between the positive side of meter 2A5M1 and terminal 2A5A4E1 (fig. 2-13). If there is no continuity, check wiring and section B of switch 2A5S2 (fig. 4-53). If switch and wiring is good, replace printed circuit board 2A5A4 (fig. 2-13).</p>
10	No indication or incorrect indication on TEST METER with SERVICE SELECTOR switch at any operate position, TEST METER switch at HIGH VOLT, and TUNE-OPERATE switch at TUNE.	<p>a. Defective high voltage power supply.</p>	<p>(1) Check for 24 \pm 2 volts dc at H.V. test point 2A5J10. If indication is correct, proceed to b below.</p> <p>(2) If indication at H.V. test point is incorrect, check bleeder resistor package 2A5A5R3 and associated wiring.</p> <p>(3) Check all wiring of high voltage power supply.</p> <p>(4) Check rectifier 2A5A2CR6 by substitution.</p> <p>(5) Check transformer 2A5A2T1 (fig. 2-34) windings (4, 5) for opens or shorts to ground.</p>

Table 2-6. Troubleshooting AM-3349/GRC-106—Continued

Item	Indication	Probable trouble	Procedure
b.	Defective metering circuit.		<ol style="list-style-type: none"> (1) Check for continuity from negative side of meter 2A5M1 to pin 3 of relay 2A5A3K1, to 2A5A5R3 and to negative terminal of rectifier 2A5A2CR6. Check for 6.4 ± 0.6 ohms between terminal 2A5A5R3E3 and ground with TEST METER switch in position other than HIGH VOLT. If any indication is incorrect, check wiring and switch 2A5S2. (2) Check for continuity between positive side of meter 2A5M1 and terminal 2A5A5E13. If there is no continuity, check wiring and switch 2A5S2. (3) Replace 2A5A5 and check continuity between H.V. test point 2A5J10 and terminal 2A5A5E12 (fig. 4-55).
11	No low voltage or high voltage indications on TEST METER with SERVICE SELECTOR switch at any operate position and with TUNE-OPERATE switch at TUNE.	a. Defective tune information ground line, t/r information line, 27 volt operate line, or dc-to-dc converter.	<ol style="list-style-type: none"> (1) Set TUNE-OPERATE switch at OPERATE, disconnect cable from RF DRIVE connector, and key RT-662/GRC or RT-834/GRC with handset. Check LOW VOLT and HIGH VOLT positions of TEST METER again. If both indications are now present, proceed to (2) below. If both indications are still missing, insure that probable trouble (b, d, and e below) does not exist. If one of these troubles exist, proceed directly to related procedure. Check for -34 volts dc at V1 BIAS VDC test point 2A1A1J6 (fig. 4-49) and V2 BIAS VDC 2A1A1J3 test point. If indication is incorrect, proceed to b (6) below. If indication is correct, proceed to (3) below. (2) Check for continuity between pins T and M of CONTROL connector 2A5J2 (fig. 4-53) (reverse leads if necessary). If there is no continuity, check associated wiring and replace 2A5A4 (fig. 2-13). If there is continuity, set TUNE-OPERATE switch at TUNE and check for continuity between pin M of CONTROL connector 2A5J2 (fig. 2-33) and pin 7 of connector 2A1A1XA7 (fig. 2-5) (remove relay assembly 2A7). If continuity does not exist, check associated wiring and switch 2A5S6 (fig. 2-33). If there is continuity, substitute new relay assembly 2A7 (fig. 2-31). (3) Remove antenna coupler assembly 2A3 (fig. 2-31) and set TUNE-OPERATE switch at TUNE. Check for 27 volts dc at terminal 2A5A3E18 (fig. 2-20). If 27 volts dc is not present, proceed to (6) below. If 27 volts dc is present at terminal 2A5A3E18, check for 27 volts dc at terminal 2A5A3E22. If 27 volts dc is not present, check for 27 volts dc at terminal 2A5A3E20. If 27 volts dc is present, replace relay 2A5A3K3. If 27 volts dc is present at terminal 2A5A3E22, check continuity to terminal 2A5A5E2. If there is no continuity, check wiring. If there is continuity, check for continuity between terminals 2A5A5E8 and 2A5A5E2 (reverse leads if necessary). If there is no continuity, replace terminal board 2A5A5 (fig. 2-16). (4) If 27 volts dc is not present at terminal 2A5A3E20, check for 27 volts dc at terminal 2A5A3E21. If 27 volts dc is not present at terminal 2A5A3E21, check for an open in associated wiring or a defective component (2A5A3R2, 2A5A3R3, 2A5A3K1, 2A5A3C1, 2A5A3VR1). If 27 volts

Table 2-6. Troubleshooting AM-3349/GRC-106—Continued

Item	Indication	Probable trouble	Procedure
			dc is present at terminal 2A5A3E21, but not at terminal 2A5A3E20, disconnect leads from terminals 2A5A4E4 (fig. 2-13) and 2A5A4E5 and from terminals +, AC1, and AC2 of rectifier 2A5CR6 (fig. 4-53). Rotate TUNE-OPERATE and back to TUNE.
			CAUTION
			Leave terminal 2A5A3E18 shorted to ground in the following, only long enough to take measurement.
			Short terminal 2A5A3E18 to ground and check for 11 ± 1.5 volts dc at terminal 2A5A3E1. If indication is correct, proceed to (5) below. If indication is not correct, replace 2A5A3 and check associated wiring. Check all dc-to-dc converter wiring, and replace board 2A5A6 (fig. 2-14) (c (1) and (2) below).
			(5) If 11 ± 1.5 volts dc is present at terminal 2A5A3E1, remove short from terminal 2A5A3E18 and rotate TUNE-OPERATE switch to OPERATE and back to TUNE. Check for 11 ± 1.5 volts dc at terminal 2A5A3E1. If it is still present, check 2A5A4 (fig. 2-13), 2A5CR6, and associated wiring for shorts to ground. If no defect is found, proceed to b below. If the 11 ± 1.5 volts dc is not present, replace short at terminal 2A5A3E18 and check for 0 volt indication at terminal 2A5A3E9. If a 0 volt indication is obtained, check for 27 volts dc at terminal 2A5A3E13. If 27 volts dc is present replace 2A5A3K2 and repeat process to insure that fault is corrected. If 27 volts dc is not present at terminal 2A5A3E13, check for an open 27 volts dc operate line to terminal 2A5A3E13. If a 27 volt indication is obtained at terminal 2A5A3E9, replace assembly 2A5A7 (fig. 2-33).
			(6) If 27 volts dc is not present at terminal 2A5A3E18, check for 27 volts dc at pins 3 and 7 of relay 2A5A2K2 (fig. 2-34). If 27 volts dc is not at pin 3, but is at 7, check relay 2A5A2K2 and associated wiring. If 27 volts dc is not present at either pin, check continuity between pin 7 of relay 2A5A2K2 and pin 8 of connector 2A1A1XA7 (fig. 4-49) and between pin Y of CONTROL connector 2A5J2 (fig. 2-33) and pin 10 of connector 2A1A1XA7. If above procedures do not correct fault, substitute new relay assembly 2A7 and recheck to see that fault is corrected.
	b. An overload condition in power amplifier 2A1A1V1-2A1A1V2, low voltage power supply, high voltage power supply, or no bias voltage.		(1) Rotate turret by hand far enough to disengage all contacts and check continuity to ground at pin 1 of connector 2A1A1XA9-A (fig. 4-49). If continuity exists, check plenum 2A1A1 (fig. 2-18) wiring and components to isolate short circuit. (2) Check continuity to ground at stator contacts 1 through 4 and 6 through 10 (B, fig. 2-24). If continuity exists at any point, stator assembly 2A9 is defective. (3) Set RT-662/GRC or RT-834/GRC 1 MHz control at any position other than one in use. If fault is corrected, replace filter assembly that was originally connected into circuit and resume operation.

Table 2-6. Troubleshooting AM-3349/GRC-106—Continued

Item	Indication	Probable trouble	Procedure
			<ul style="list-style-type: none"> (4) If short to ground still exists, check plenum assembly 2A1A1 components: 2A1A1C20 (fig. 2-18), 2A1A1C21, and 2A1A1C22. See drawing on plate on bottom of AM-3349/GRC-106 chassis. (5) Check for -34 volts dc at V1 BIAS VDC (fig. 2-18) and V2 BIAS VDC test points. If indication is correct, proceed to (9) below. (6) If indication is incorrect, check for -110 ±11 volts dc at BIAS SUPPLY VDC test point 2A1A1J4 (fig. 2-18). If indication is correct, check wiring from terminals 2A1A1A1E3 (fig. 2-11) and E4 to control guides of 2A1A1V1 (fig. 2-18) and 2A1A1V2. If wiring is good, replace board 2A1A1A1 and proceed to (8) below. (7) If indication is incorrect at BIAS SUPPLY VDC test point, check for continuity from test point to pin 13 of connector 2A5J1 (fig. 2-33). If continuity exists, check wiring and following components in dc-to-ac inverter assembly 2A6A1 (fig. 2-18); CR1 through CR4, C4, R4, R5. (8) If indication at V1 BIAS VDC and V2 BIAS VDC test points is still incorrect, check capacitors 2A1A1C10 (fig. 2-18) and 2A1A1C11. (9) Check capacitor 2A1A1C3. If capacitor 2A1A1C3 is defective, check capacitors 2A1A1C4 and 2A1A1C24 and resistor 2A1A1R7. Replace if defective. (10) Check capacitor 2A1A1C2. If capacitor 2A1A1C2 is defective, check capacitor 2A8C2 (fig. 2-23). Also, check for approximately 3 to 4 volts rf at pin 8 of 2A8V1 tube socket. If indication is incorrect, replace 2A8A1 (fig. 2-15).
		c. Defective dc-to-dc converter assembly.	<ul style="list-style-type: none"> (1) Check following components: 2A5A2Q2 (fig. 2-34), 2A5Q1, 2A5A2R1 (fig. 2-33), 2A5A5R2, 2A5A1VR1 (fig. 2-21), 2A5A2VR1, (fig. 2-34), all windings of transformers 2A5A2T1 and 2A5A2T2, and relay 2A5A2K2. Check all interconnecting wiring. Repair or replace as necessary. (2) If procedures in (1) above do not isolate fault, replace 2A5A6 (fig. 2-14).
		d. Turret does not stop rotating.	(1) Check relay assembly 2A7 (fig. 2-31).
		e. Antenna coupler assembly 2A3 motors do not stop.	Replace antenna coupler assembly 2A3 (fig. 2-31).
12	Cannot adjust ANT. TUNE and ANT. LOAD controls for a correct indication on the ANT. TUNE and ANT. LOAD meters.	a. No driver current	Check for an indication of driver current (switch in DRIVER CUR position) on TEST METER. If present, proceed to <i>b</i> below. If not present, proceed to item 13.
		b. No plate current (idle).	Check for an indication of plate current (idle) on TEST METER (switch in PA CUR. position). If present, proceed to <i>c</i> below. If not present, proceed to item 14.
		c. No grid drive	Check for an indication of grid drive on TEST METER (switch in GRID DRIVE position). If present, proceed to <i>d</i> below. If not present, proceed to item 15.

Table 2-6. Troubleshooting AM-3349/GRC-106—Continued

Item	Indication	Probable trouble	Procedure
d.	No or low power output.		Check for an indication of power output on TEST METER (switch in POWER OUT position). If no indication is present, proceed to item 16a(2). If indication is present but low, proceed to e below.
e.	Defective mechanical coupling.		Check mechanical couplings between front panel controls, and variable capacitor and inductor (2A3C26 and 2A3L1) in antenna coupler assembly 2A3 (fig. 2-36 and 2-37). Check to see that counter gear train is complete and engaged properly.
f.	Defective capacitor 2A3C26 or inductor 2A3L1.		<p>(1) Rotate ANT TUNE control and check to see that plates of capacitor 2A3C26 (fig. 2-37) move as control is rotated. If plates move, proceed to (2) below. If plates do not move, remove antenna coupler assembly 2A3 and replace with new antenna coupler assembly 2A3.</p> <p>(2) Rotate ANT LOAD control and note ME-26/U indication (connected between terminal 1 of 2A3L1 and ground). If indication is intermittent, remove antenna coupler assembly 2A3 and replace with new antenna coupler assembly 2A3. If indication remains constant, proceed to g below.</p>
g.	Defective programing in turret assembly 2A2 or antenna coupler assembly 2A3.		Check programing in turret assembly 2A2 and antenna coupler assembly 2A3. If programing appears to be right, proceed to h below. If programing is not correct, determine number of channel or channels not programing correctly. Remove antenna coupler assembly 2A3 and determine which pin of connector 2A1XA3 is connected to contact (corresponding to defective channel number) of switch 2A2S5 (fig. 4-50) (defective 50 ohm line programing) or switch 2A2S4 (defective whip programing). Check continuity between determined connector pin and ground. If there is continuity, isolate trouble by checking continuity between corresponding pin of connector 2A3J1 and contact 20 of switch 2A3S3 (fig. 2-37) and/or contact 4 of switch 2A3S2 (fig. 2-36). If there is no continuity, isolate trouble by checking for continuity between-determined connector pin and the common (C) contact of switch 2A2S4 and/or 2A2S5.
h.	Defective discriminator assembly 2A4.		<p>(1) Remove antenna coupler assembly 2A3. Connect 50 ohm load (DA-75/U) to connector 2A4P3 (fig. 4-52). Set PRIM. PWR. circuit breaker at ON. Using ME-2(*)/U, check for approximately 0.8 volts dc between each of pins 2 and 8 of connector 2A1P2 and ground. Voltage at both pins should be equal when ANT LOAD meter is zeroed (center scale indication). If indications are correct, proceed to (2) below. If indications are not correct, discriminator assembly 2A4 is defective.</p> <p>(2) Using ME-26(*)/U, check for 1.5 to 4.5 volts dc between each of pins 1 and 7 of connector 2A1P2 (fig. 4-49) and ground. Voltage at both pins should be equal when ANT TUNE meter is zeroed (center scale indication). If indications are correct, proceed to i below. If indications are not correct, discriminator assembly 2A4 is defective.</p>
i.	Defective meter circuit.		Check meter circuit for defective components (2A5C5 (fig. 2-33), 2A5C6, 2A5A5R7, 2A5A5R8, 2A5M2, 2A5M3, and 2A5S6).

Table 2-6. Troubleshooting AM-3349/GRC-106—Continued

Item	Indication	Probable trouble	Procedure
13	No indication or incorrect indication on TEST METER with SERVICE SELECTOR switch at any operate position, TEST METER switch at DRIVDR CUR, and TUNE-OPERATE switch at TUNE.	a. Defective driver tube 2A8V1.	Inspect tube 2A8V1 to see if its filaments are lit. If filaments are lit, proceed to <i>b</i> below. If filaments are not lit, replace tube 2A8V1 (para 2-24) and make the adjustments. If filaments of new tube do not light, proceed to <i>c</i> below.
		b. Defective metering circuit.	<p style="text-align: center;">NOTE</p> <p>2A8A1R6 is located on the back of AM-3349/GRC-106 chassis.</p> <ol style="list-style-type: none"> (1) If driver current is too high, remove cable from RF DRIVE connector. Driver current should now indicate normal. If not, adjust driver 2A8V1 bias (para 2-24). (2) If driver current is not present or is low, set TEST METER switch at GRID DRIVE. Test meter should indicate just left of the light green wedges. If indication is low, adjust driver 2A8V1 bias. If there is no indication, proceed to <i>b</i> below. If indication is correct, proceed to (3) below. (3) Check continuity between negative side of meter 2A5M1 and chassis ground. If there is no continuity, check wiring and section A of TEST METER switch 2A5S2. Rotate 2A5S2 to a position other than DRIVER CUR. (4) Check for $240K \pm 5\%$ between positive side of meter 2A5M1 and pin 9 of 2A8V1 tube socket. If indication is incorrect, check wiring and section B of switch 2A5S2.
		c. Defective filament supply for 2A8V1.	<ol style="list-style-type: none"> (1) Check to see that 2A8V1 filaments are lighted. If they are, proceed to <i>d</i> below. (2) If filaments are not lighted, check for 6.3 volts ac (peak) at FILAMENT VAC test point A8J6 (fig. 2-3). If indication is correct, repair wiring to 2A8V1 tube socket. (3) If indication in (2) above is incorrect, trace filament supply lines back to transformer 2A6A1T1 (fig. 3-59). (4) If wiring is good, refer to item 3<i>b</i> to isolate malfunction in dc-to-dc inverter assembly 2A6A1.
		d. Defective bias circuit for driver amplifier 2A8V1.	<ol style="list-style-type: none"> (1) Remove 2A8V1 (para 2-24), and check for approximately -13 volts dc between pin 8 of 2A8V1 tube socket and ground. If indication is correct, proceed to (3) below. If -13 volts dc is not present, check continuity (approximately $46K\Omega$) between pin 8 of 2A8V1 tube socket and ground. If $46K\Omega$ is not read, replace board 2A8A1 (fig. 2-15). (2) If $46K\Omega$ is present in (1) above, remove driver assembly 2A8. Set PRIM. PWR. switch at ON and check for 27 volts dc at pin 3 of connector 2A1A1XA8. If present, check wiring between 2A8J1 terminal 2A8A1E4 (fig. 2-15). If 27 volts dc is not present, check wiring to terminal 2A1A1E14. (3) If voltage in step (1) is correct, check for approximately 820 ohms between pin 7 of 2A8V1 tube socket and ground and between pin 9 of 2A8V1 tube socket and ground. If either indication is incorrect, replace board 2A8A1 (fig. 2-15).
		e. Defective 2A8V1 plate circuit.	<ol style="list-style-type: none"> (1) Check for 200 volts dc at PLATE VDC test point 2A8J4. If indication is correct, proceed to (2) below. If incorrect, check for 200 volts dc at terminal 2A1A1E15. If 200 volts dc is present, check for about $7.5K\Omega$ between pins 1 and 3 of 2A8V1 tube socket. If 200 volts dc is not present, check following components: 2A1R5, 2A1R6, 2A1A1VR3, and 2A8C4 (fig. 2-23).

Table 2-6. Troubleshooting AM-3349/GRC-106—Continued

Item	Indication	Probable trouble	Procedure
			<ul style="list-style-type: none"> (2) Check for 200 volts dc at pin 1 of 2A8V1 tube socket. If indication is correct, proceed to <i>e</i> below. If incorrect, change frequency settings of RT-662/GRC or RT-834/GRC MHz and kHz controls so that another interstage transformer is connected into circuits. Check voltage again at pin 1 of 2A8V1 tube socket. If now correct, inspect driver assembly 2A8 stator block for intermittent contacts. If contacts are good replace interstage transformer (2A2A16 through 2A2A30) that was originally connected in circuit. If 200 volts dc still is not present, proceed to (3) below. Remove driver assembly 2A8. (3) Check for continuity between pin 1 of 2A8V1 tube socket and contact 1 of driver assembly 2A8 stator block (C, fig. 2-23) and between PLATE VDC test point and contact 2 of driver assembly 2A8 stator block. (4) If first indication ((3) above) is incorrect, check wiring of driver assembly 2A8. (5) If second indication ((3) above) is incorrect check inductor 2A8L1 (fig. 2-23), capacitors 2A8C4, 2A8C5, 2A8C6, and associated wiring.
		f. Defective screen grid circuit of 2A8V1.	<ul style="list-style-type: none"> (1) Check for 164 volts dc at SCREEN VDC test point A8J5 (fig. 2-3). (2) If indication is incorrect, check wiring in screen grid circuit and following components: 2A8VR1 (fig. 2-23), 2A8VR2, 2A8R2, and 2A8C3.
14	No indication or incorrect indication on TEST METER with SERVICE SELECTOR switch at any operate position. TEST METER switch at PA. CUR and TUNE-OPERATE switch at TUNE.	a. Defective output tube 2A1A1V1 and/or V2.	Remove power from the unit.
		b. Defective metering circuit.	
			<p style="text-align: center;">WARNING</p> <p>Dangerous voltages may exist on output tubes even when power is disconnected. Do not touch tube without first shorting tube case to ground.</p> <p>Take cover off top of plenum assembly 2A1A1. Use insulated handle screwdriver to short plenum case (ground) to top of output tubes 2A1A1V1 and V2. With tubes shorted, touch top of tubes to determine if they are heating. If not, replace cool tube(s) and make adjustments of paragraph 2-21. If tube still does not heat, proceed to <i>g</i> below. If new tube heats but TEST METER is still incorrect, proceed to <i>b</i> below.</p> <ul style="list-style-type: none"> (1) Check for proper indication on TEST METER with switch in POWER OUT position. If indication is incorrect, proceed to <i>b</i> below. If indication is correct, proceed to (2) below. (2) Check for continuity between positive side of TEST METER 2A5M1 and chassis ground. If there is no continuity, check wiring. If wiring is good, section B of TEST METER switch 2A5S2 is defective. (3) Check for continuity between the negative side of meter 2A5M1 and terminal 2A5A5E5. If there is no continuity, check wiring. If wiring is good, section A of switch 2A5S2 is defective. (4) Replace 2A5A5 if 2A5A5R1, 2A5A5R3, or 2A5A5R4 (fig. 2-33) is suspected, or has been proven faulty.

Table 2-6. Troubleshooting AM-3349/GRC-106—Continued

Item	Indication	Probable trouble	Procedure
			(5) Check for continuity between terminal 2A5A5E7 and contact 6 of section A of switch 2A5S2. If there is continuity, P.A. IDLER CUR. switch 2A5S1 is defective.
	c. Defective 2 kv ground return.		Check for resistance of approximately 6 ohms between negative terminal of diode 2A5A2CR6 and ground. If present, proceed to c below. If not present, one of following is open: wiring between negative terminal of diode 2A5A2CR6 and pin 3 of relay 2A5A3K1, coil of relay 2A5A3K1, wiring between terminal 7 of relay 2A5A3K1 and terminal 2A5A5E4, wiring between 2A5A5E5 and contact 6 of switch 2A5S2A, or contact 6 of switch 2A5S2A.
	d. Defective 2 kv line.....		Check continuity between positive terminal of diode 2A5A2CR6 and plates of tubes 2A1A1V1 and 2A1A1V2. If there is continuity, proceed to e below. If there is no continuity, inductor 2A1A1L3 or interconnecting wiring is open.
	e. Defective screen supply.		(1) Check for 400 volts dc at the SCREEN VDC test point 2A1A1J8. If indication is correct, proceed to (2) below. If indication is not correct, one or more of the following is defective: 2A1A1VR1, 2A1A1VR2, 2A1R3, or 2A1R4. (2) Check for defective screen resistor 2A1A1R1 or 2A1A1R2.
	f. Defective bias supply.		(1) Check for approximately -34 volts dc at V1 BIAS VDC 2A1A1J6 (see drawing on bottom of AM-3349/GRC-106 chassis) and V2 BIAS VDC 2A1A1J3 test points (fig. 2-31). If both indications are correct, proceed to (2) below. If both indications are incorrect, proceed to (3) below. If only the V1 bias is incorrect, proceed to (4) below. If only V2 bias is incorrect, proceed to (5) below. (2) Check for an open inductor 2A1A1L1 (fig. 2-18) or 2A1A1L2 or wire between inductors and grids of tubes 2A1A1V1 and 2A1A1V2. If no open exists, proceed to f below. (3) Check for -110 ± 11 volts dc at BIAS SUPPLY VDC 2A1A1J4 test point. If not present, wiring between terminal 2A1A1E12 and resistor 2A6A1R5, capacitor 2A6A1C4, resistor 2A6A1R4, or diodes 2A6A1CR4 through 2A6A1CR7 (fig. 2-17) are defective. If present, wiring between terminals 2A1A1E12 and 2A1A1A1E1, or assembly 2A1A1A1 is defective (fig. 2-11). (4) Check for defect in connection between 2A1A1E3 and inductor 2A1A1L1 (fig. 4-49) or assembly 2A1A1A1. (5) Check for defect in connection between 2A1A1A1E4 and inductor 2A1A1L2 or assembly 2A1A1A1.
	g. Defective filament supply, or defective filament regulator.		(1) Check input of filament regulator 2A1A1A2. If voltage is 27.0 ± 1.0 volts dc proceed to (2). If not, check wiring from input back to 27 volt dc input at 2A5J7 pin A or B (fig. 4-53). (2) Check output of filament regulator 2A1A1A2. If voltage is 25.5 ± 1.0 volts dc, proceed to (3) below. If not, check circuitry of filament regulator according to fig. 2-41. (3) Check for defect in filament wiring between terminal 2A1A1E29 (fig. 4-49) and pin 3 of 2A1A1V2 tube socket and pin 7 of 2A1A1V1 tube socket. Check for defective grounding of pin 7 of 2A1A1V2 tube socket and pin 3 of 2A1A1V1 tube socket.

Table 2-6. Troubleshooting AM-3349/GRC-106—Continued

Item	Indication	Probable trouble	Procedure
15	No indication or incorrect indication on TEST METER with TEST METER switch at GRID DRIVE, and TUNE-OPERATE switch at TUNE.	Defective metering circuit, driver assembly 2A8A1, assembly 2A1A1A1, turret assembly 2A2, or wiring.	<ol style="list-style-type: none"> (1) Change settings of RT-662/GRC or RT-834/GRC MHz and kHz controls so that interstage transformer connected in circuit is changed. Check meter indications again. If fault is corrected, check driver assembly 2A8 stator block (A, fig. 2-23) for intermittent contacts. If contacts are good, replace interstage transformer that was originally connected in circuit. (2) Set TEST METER switch at POWER OUT. TEST METER should indicate just left of light green wedges. If indication is correct, check for defective resistor A5A5R5 (fig. 2-16) or contact 5 of switch 2A5S2B (fig. 2-33). If there is no indication, proceed to (4) below. If indication is high, proceed to (3) below. (3) Check wiring between grids of tubes 2A1A1V1-2A1A1V2 and terminal 2A1A1E7 (fig. 4-49), and between terminal 2A1A1A1E8 and contact 5 of switch 2A5S2B for open or short circuit. If no defect is found, check components of assembly 2A1A1A1 (fig. 2-11). (4) Remove driver tube 2A8V1 (TM 11-5820-520-12). Check at pin 8 of 2A8V1 tube socket for approximate 7 volt, ac level. If present, proceed to (5) below. If not present, one of following is defective: shorted or open connection between connector 2A8P1 (fig. 4-16) and RF DRIVE connector 2A5J3 (fig. 4-53), or components of assembly 2A8A1 (fig. 2-15). (5) Remove cable between RF DRIVE connectors and connect AN/GRM-50 to AM-3349/GRC-106 rf drive connector. Connect ME-26(*)/U (using ac probe) to RF GRID DRIVE test point 2A1A1J5 (fig. 4-49). Sweep frequency output of the AN/GRM-50 above and below frequency range of interstage transformer connected in circuit. If peak is noted on ME-26(*)/U below interstage frequency range, diode 2A1A1A1CR1 (fig. 2-11) may be defective. If there is peak indication on ME-26(*)/U above interstage frequency range, one of coupling capacitors is open (2A1A1C5 (fig. 2-18), 2A1A1C6, 2A1A1C18, and 2A1A1C19). If there is no ME-26(*)/U indication, stator contact 3 or 4 on driver assembly 2A8 connections between stator contacts 3 and 4 pins A3 and A2 of connector 2A8J1 (fig. 2-5 and 2-23) are defective.
16	No indication on TEST METER with METER switch set at POWER OUT and TUNE-OPERATE switch set at TUNE.	a. Defective TEST METER 2A5M1, discriminator assembly 2A4, or antenna coupler assembly 2A3.	<ol style="list-style-type: none"> (1) Connect the ME-26(*)/U (using ac probe) to DA-75/U and note indication. If approximately 50 volts, proceed to (2) below. If zero, proceed to b below. (2) Remove antenna coupler assembly 2A3. Connect DA-75/U to connector 2A4P3 (fig. 4-52) and connect ME-26(*)/U across DA-75/U. Set PRIM. PWR. circuit breaker at ON. ME-26(*)/U should indicate approximately 53 volts. If indication is not correct, proceed to b below. If the indication is correct, proceed to (3) below. (3) Note TEST METER indication. If TEST METER now indicates power output, coaxial cable between capacitor 2A3C26 (fig. 2-37) and connector 2A3J2 (fig. 4-51) is defective. If TEST METER still does not indicate, proceed to (4) below.

Table 2-6. Troubleshooting AM-3349/GRC-106—Continued

Item	Indication	Probable trouble	Procedure
17	No power output at 50 OHM LINE and/or WHIP connector.	<p>a. Defective 50 OHM LINE flag switch 2A5S5.</p>	<p>(4) Connect ME-26(*)/U to pin 10 of connector 2A4J2 (fig. 4-52) and check for approximately 5 volts dc. If present, isolate fault by making continuity measurements between pin 10 of connector 2A1P2 and positive side of TEST METER 2A5M1. If 5 volts dc is not present, discriminator assembly 2A4 is defective.</p> <p>(1) Using ME-26(*)/U check continuity between center pin of connector 2A4P3 (fig. 4-52) and ground. If there is continuity, proceed to (2) below. If there is no continuity, there is open circuit between contact No. 6 of stator assembly 2A9 (B, fig. 2-24) and center pin of connector 2A4P3 or between contact No. 5 of stator assembly 2A9 and ground.</p> <p>(2) Rotate turret assembly 2A2 by hand until turret contacts disengage from contacts of stator assembly 2A9. ME-26(*)/U should indicate open circuit. If correct, proceed to (3) below. If not correct, there is short circuit in coaxial connections between contact 6 of stator assembly 2A9 (B, fig. 2-24) and connector 2A4P3.</p> <p>(3) If (1) and (2) above failed to isolate fault, perform procedures in paragraph 2-15.</p>
		<p>b. Defective relay 2A5K1.</p>	<p>(1) Check for continuity from 50 OHM LINE connector to common contact of flag switch 2A5S5 (fig. 2-33) and from WHIP connector to common contact of 2A5S5. If there is no continuity, check wiring between connectors and switch. If wiring is good, replace flag switch.</p> <p>(2) Set RT-662/GRC or RT-834/GRC MHz and kHz controls at 03000 and allow automatic programming to be completed.</p> <p>(3) Check for continuity between WHIP connector and ground. If continuity exists, trace rf output line back from WHIP connector to isolate short circuit ground.</p> <p>(1) Disconnect cable from RF DRIVE connector and set TUNE-OPERATE switch at TUNE.</p> <p>(2) Check continuity between 50 OHM LINE connector and switch 2A3S1 (fig. 2-37), and between WHIP connector and switch 2A3S1.</p> <p>(3) If there is no continuity, check wiring between the common contact of switch 2A5S5 (fig. 2-33) and relay 2A5K1 and from relay 2A5K1 to switch 2A3S1 (fig. 2-37).</p> <p>(4) If wiring is good, check for continuity between terminal 2A5A3E22 (fig. 2-20) and contact L2 of relay 2A5K1 (fig. 2-33).</p> <p>(5) If wiring ((4) above) is good, remove relay assembly 2A7 (fig. 3-62) and check for continuity between pin 8 of connector 2A1A1XA7 (fig. 2-5 and 4-53) and contact L1 of relay 2A5K1.</p> <p>(6) If all wiring is good, replace relay 2A5K1.</p>
		<p>c. Defective antenna coupler assembly 2A3.</p>	<p>(1) Set RT-662/GRC or RT-834/GRC MHz and kHz controls at 02000 and allow automatic programming to be completed.</p> <p>(2) Check for continuity between WHIP connector and variable capacitor 2A3C26 (fig. 2-37). If there is no continuity, check switch 2A3S1 and associated wiring.</p>

Table 2-6. Troubleshooting AM-3349/GRC-106—Continued

Item	Indication	Probable trouble	Procedure
18	PRIM. PWR. circuit breaker 2A5A2CB1 (fig. 2-33) continues to trip, or intermittent power output at antenna connectors during normal operation.	a. Defective turret assembly 2A2 or stator assembly 2A9.	(1) Perform the programming checks outlined in paragraph 2-15. While performing these checks, closely watch turret assembly 2A2 (fig. 2-31) and stator assembly 2A9 (fig. 2-24) to detect any visible arcing. If arcing appears or programming is incorrect, repair as necessary. (2) Check capacitor 2A1A1C22 (fig. 2-18 and 4-49) for breakdown; replace if defective.
		b. Defective alc circuit-----	(1) With antenna coupler assembly 2A3 removed and DA-75/U connected to output of discriminator assembly 2A4, check continuity between pin F of CONTROL connector 2A5J2 (fig. 2-33) and pin A1 of connector 2A1P2 (fig. 4-49). If there is no continuity, isolate any opens by checking feed-through capacitor 2A1A1C13 and inductor 2A5A1A2L6 (fig. 2-22) and wiring. (2) Check for short circuit to ground from pin F of CONTROL connector 2A5J2 (fig. 2-33) and from pin A1 of connector 2A1P2. If there is continuity, check capacitors 2A5A1A2C8 (fig. 2-21 and 2-34) and 2A5A1A2C6. Check these connectors and wiring between them.
19	AM-3349/GRC-106 remains keyed at all times.	Defective t/r information ground line.	Check capacitors 2A5A1A1C6, 2A5A1A1C7, and 2A5A1A1C8 for shorts to ground.
20	No signal received at RT-662/GRC or RT-834/GRC when in receive mode.	Defective flag switch 2A5S5 or relay 2A5K1.	Same as item 17, a and b.
21	No TEST METER indication on some operating bands with TEST METER switch set to DRIVER CUR. or PA. CUR.	Maladjusted switch 2A2S1 (fig. 3-67).	Adjustment of turret is required at general support level maintenance.
22	Turret does not rotate when setting of MHz and kHz controls is changed and TUNE-OPERATE switch is at TUNE. (No TEST METER indication with switch set to DRIVER CUR, PA CUR, or POWER OUT.)	a. Defective 27 volt dc line. b. Defective code lines----- c. Defective motor 2A2B1 or shorted zener diode 2A2A3VR1 or capacitor 2A7C2.	Remove turret drum, turret base, and relay assemblies. Check wiring between pin 1 of connector 2A1XA2 (fig. 4-49) and pin 4 of connector 2A1A1XA7 (fig. 2-5). Check each of following connections for open or short: (1) Pin 16 of connector 2A1XA2 to pin Z of connector 2A5J2 (fig. 2-33). (2) Pin 17 of connector 2A1XA2 to pin a of connector 2A5J2 (fig. 2-6). (3) Pin 18 of connector 2A1XA2 to pin b of connector 2A5J2. (4) Pin 19 of connector 2A1XA2 to pin c of connector 2A5J2. (5) Pin 34 of connector 2A1XA2 to pin d of connector 2A5J2. With turret assembly 2A2 removed, apply 27 volts dc to pin 1 of connector 2A2J1 (fig. 4-50). If motor runs, proceed to d below. If motor does not run, check wiring between pin 1 of connector 2A2J1 and motor 2A2B1. Check for shorted zener diode 2A2A31VR1 or capacitor 2A7C2 (fig. 4-55). If defective, repair or send to higher maintenance level as necessary. If no defect is found, replacement of motor 2A2B1 must be accomplished at depot level.

Table 2-6. Troubleshooting AM-3349/GRC-106—Continued

Item	Indication	Probable trouble	Procedure
23	Antenna coupler 2A3 does not automatically program after turret programming is completed.	d. Defective relay return line.	Check wiring between pin 24 of connector 2A1XA2 and pin 5 of connector 2A1A1XA7 for an open or short. Repair if necessary.
		e. Defective turret assembly 2A2.	Check wiring between pins 16, 17, 18, 19, 34, and 24 of connector 2A2J1 and corresponding contacts 1, 2, 3, 4, 5, and C of switches 2A2S2 (fig. 4-26) and 2A2S3. Repair any wiring found defective.
		f. Defective motor 2A7K1.	(1) Replace relay assembly 2A7 (fig. 3-62).
		a. Defective motor 2A3B1.	(1) Remove antenna coupler assembly 2A3 and relay assembly 2A7. Apply 27 volts dc to pin 14 of connector 2A3J1. If motor now rotates, proceed to <i>b</i> below.
			(2) If motor does not rotate, check wiring between pin 14 of connector 2A3J1 (fig. 2-37) and motor and from other side of motor to ground. Repair as necessary.
			(3) If wiring is good, replace motor 2A3B1 (fig. 4-51).
		b. Defective motor 2A3B2.	(1) Apply 27 volts dc to pin 22 of connector 2A3J1. If motor now rotates, proceed to <i>c</i> below.
			(2) If motor does not rotate, check wiring between pin 22 of connector 2A3J1 and motor and from other side of motor to ground. Repair as necessary.
			(3) If wiring is good, replacement of motor 2A3B2 is necessary at depot level maintenance.
			c. Defective 27 volt lines.
		(2) Check for continuity between pin 22 of connector 2A1XA3 and pin 3 of connector 2A1A1XA7. Repair wiring as necessary.	
	d. Defective relay return lines.	(1) Check continuity between pin 12 of connector 2A1XA3 and pin 9 of connector 2A1A1XA7. Repair wiring as necessary.	
		(2) Check for continuity between pin 23 of connector 2A1XA3 and pin 2 of connector 2A1A1XA7. Repair wiring as necessary.	
	e. Defective relay assembly 2A7.	Replace relay assembly 2A7 (fig. 2-31).	
24	Rough-tuned settings of ANT. TUNE and ANT. LOAD controls inconsistent.	Automatic program malfunction.	Unit must be repaired at higher maintenance level.

2-14. Voltage and Resistance Measurements

a. *Vacuum Tubes.* Table 2-7 lists the nominal voltage and resistance (dc to ground) indications at each pin of the three vacuum tubes in the AM-3349/GRC-106. The voltage measurements are made with a primary power input of 27 volts dc, with the AN/GRC-106(*) keyed, and with the cable disconnected from the AM-3349/GRC-106 RF DRIVE connector. Resistance measurements are made with power off.

Table 2-7. AM-3349/GRC-106 Tube Voltage and Resistance Measurements

Tube	Pin No.	Voltage (dc)	Resistance (ohms)
2A8V1	1	200	6K
	2	0	0
	3	160	17K
	FIL.	6.3 (ac)	0
	FIL.	6.3 (ac)	0
	6	0	0
	7	0	820
	8	0 to 10	50K
	9	0	820
2A1A1V1	1	400	13K
	2	0	0
	3	0	0
	4	0	0

Table 2-7. AM-3349/GRC-106 Tube Voltage and Resistance Measurements—Continued

Tube	Pin No.	Voltage (dc)	Resistance (ohms)
2A1A1V2	PLATE	2,400	480K
	6	0	0
	7	27	35
	8	0	0
	GRID	-25 to -35	120K
	1	400	13K
	2	0	0
	3	0	0
	4	0	0
	PLATE	2,400	480K
2A6A1	6	0	0
	7	27	35
	8	0	0
	GRID	-25 to -35	120K

b. Transistors. Table 2-8 provides a listing of the nominal voltage indications at the three elements of the transistors in dc-to-ac inverter assembly 2A6A1. Only these transistors are accessible for such measurements without con-

siderable disassembly of the AM-3349/GRC-106. The voltages listed are actually square-wave voltages; however, when the voltages are measured with a dc voltmeter, the indications listed should be obtained. The measurements are made with a primary power input of 27 volts dc, with the AN/GRC-106(*) keyed, and with the cable disconnected from the A-3349/GRC RF DRIVE connector.

Table 2-8. AM-3349/GRC-106 Transistor Voltage Measurements

Transistor	Dc voltage to ground		
	Emitter	Base	Collector
2A6A1Q1	0	-3.5	+27
2A6A1Q2	0	-3.5	+27

c. Terminals (E). Table 2-9 provides a listing of the nominal voltage indications at the terminal junctions of the AM-3349/GRC-106.

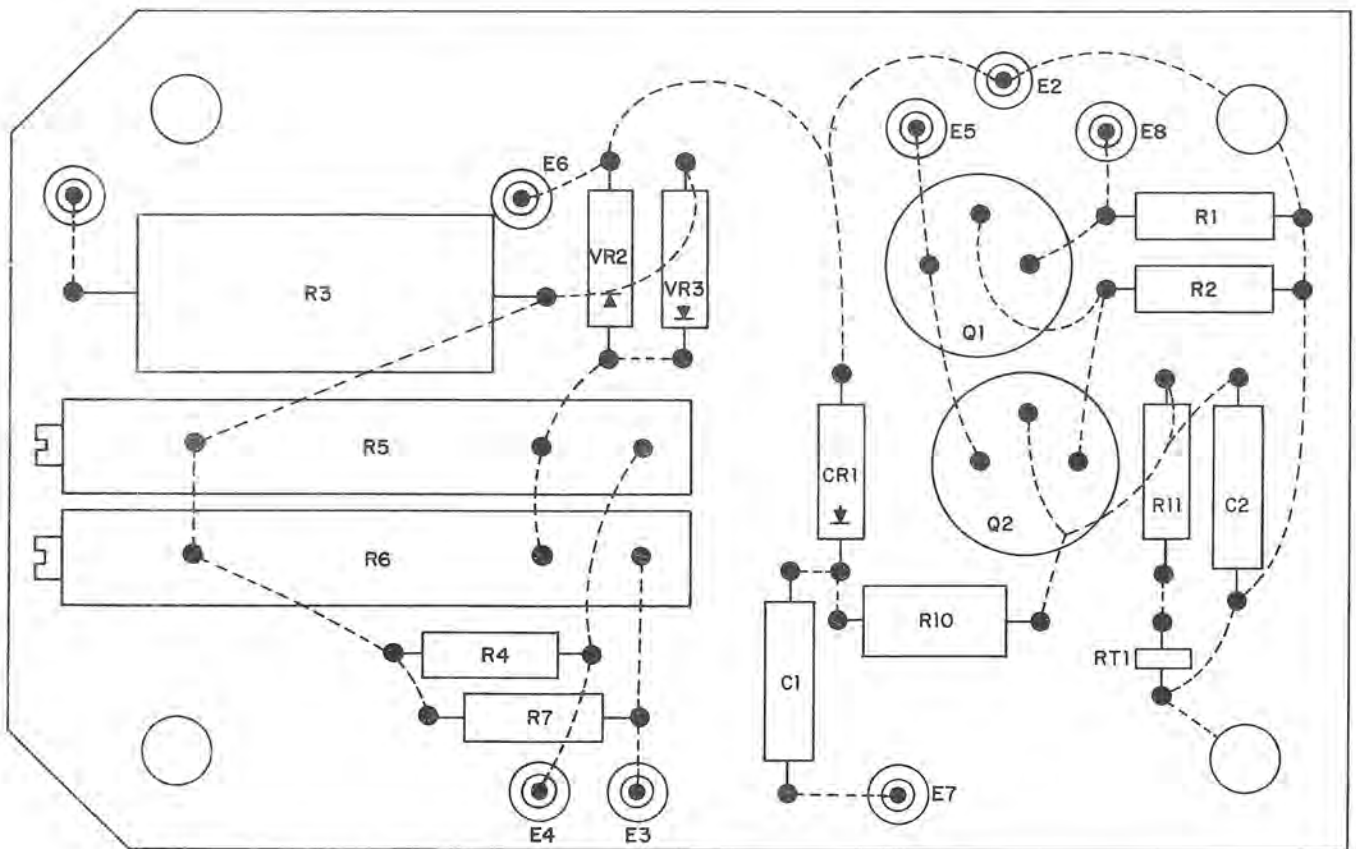

- NOTES:
1. CIRCUIT VIEWED FROM SIDE ON WHICH PARTS ARE MOUNTED.
 2. — PARTS AND PIGTAILS ON FRONT OF BOARD.
 3. - - - WIRING ON BACK OF BOARD.

TM5820-520-35-811

Figure 2-11. Tune APC assembly board 2A1A1A1, parts location diagram.

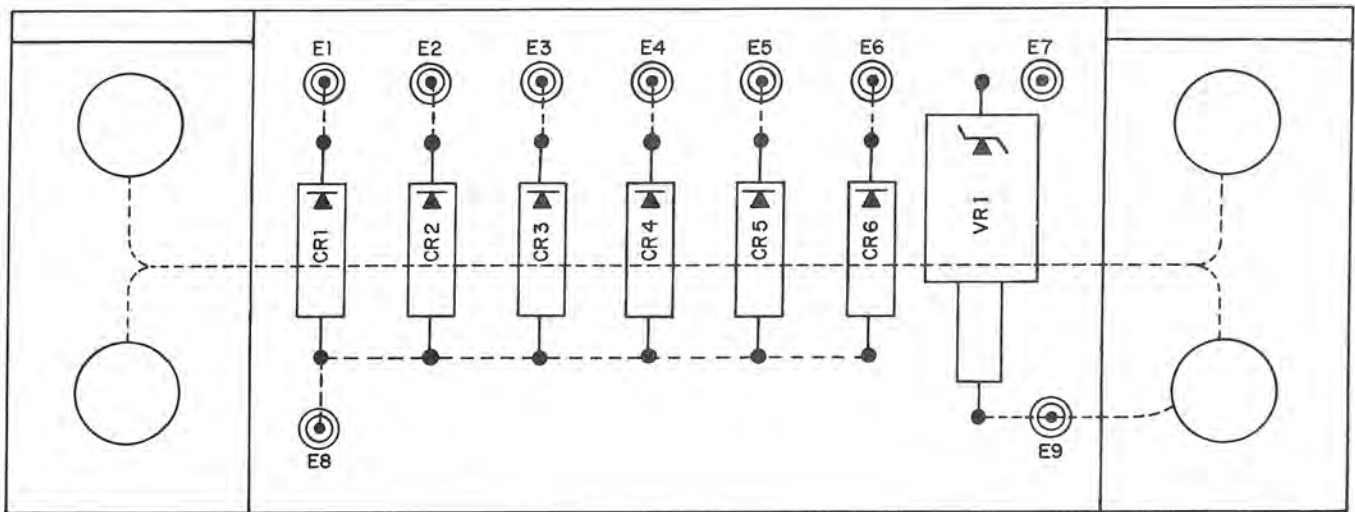

NOTES:

1. CIRCUIT VIEWED FROM SIDE ON WHICH PARTS ARE MOUNTED.
2. — PARTS AND PIGTAILS ON FRONT OF BOARD.
3. --- WIRING ON BACK OF BOARD.

TM5820-520-35-812

Figure 2-12. Coding assembly board 2A2A31, parts location diagram.

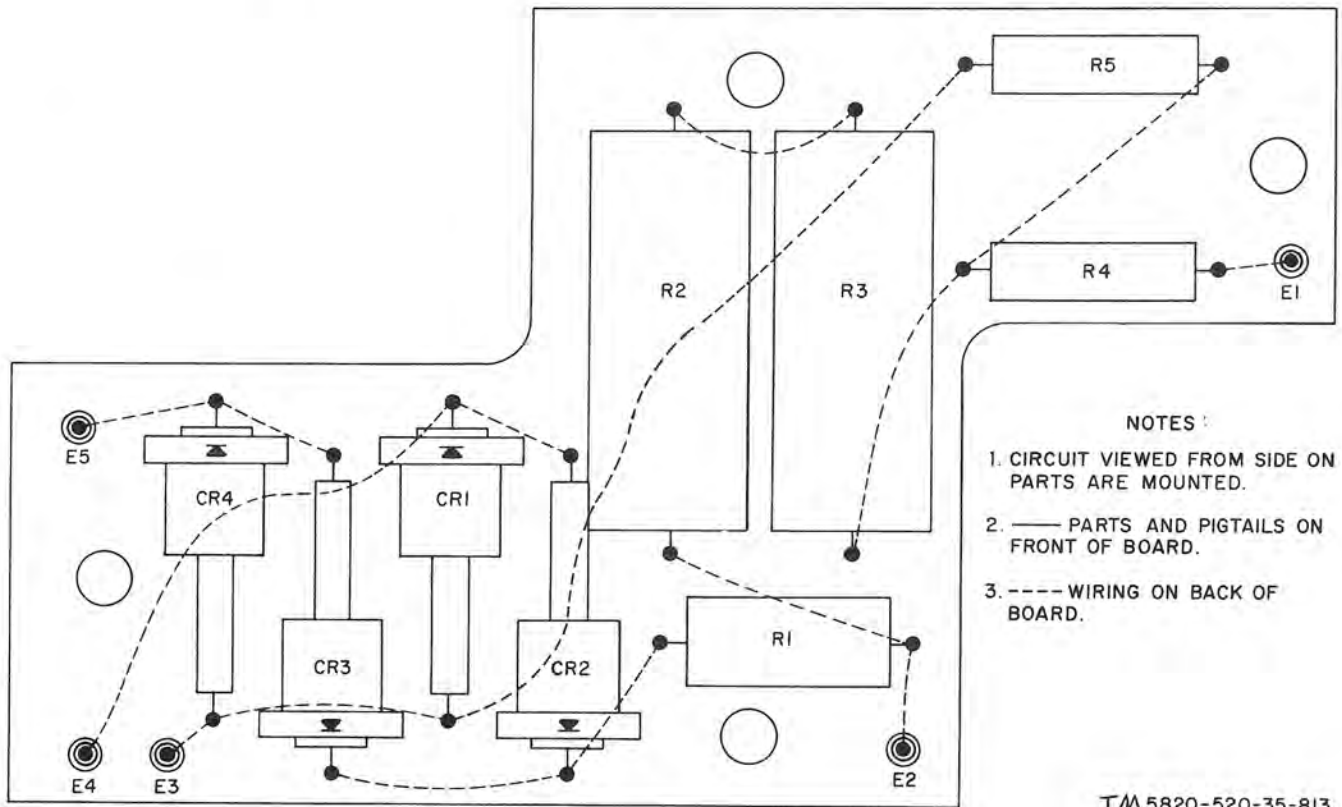

NOTES:

1. CIRCUIT VIEWED FROM SIDE ON WHICH PARTS ARE MOUNTED.
2. — PARTS AND PIGTAILS ON FRONT OF BOARD.
3. --- WIRING ON BACK OF BOARD.

TM 5820-520-35-813

Figure 2-13. Printed circuit board 2A5A4, parts location diagram.

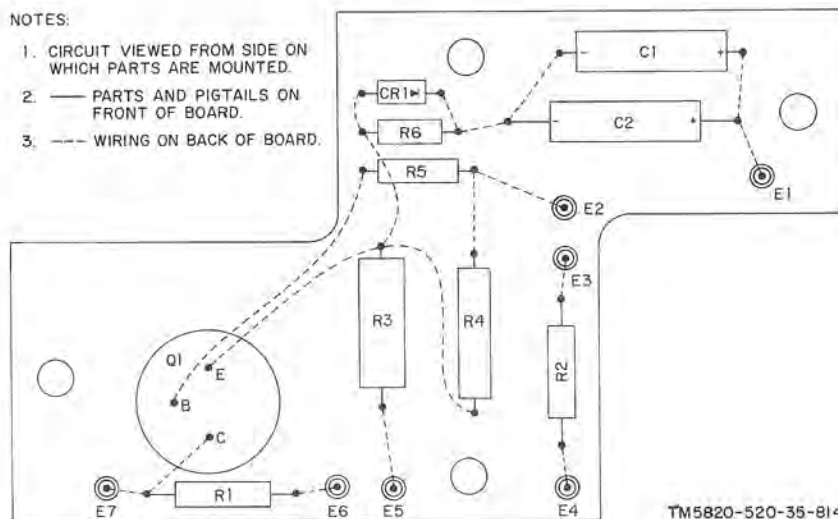

Figure 2-14. Printed circuit board 2A5A6, parts location diagram.

In each case, the kind of voltage (ac or dc) is specified. These measurements are made under the following conditions: primary power, 27 volts dc; keyed; no rf drive; idle current, 100 ma.; and front panel assembly 2A5 removed from the chassis and extension cable connected between the front panel and the chassis.

Table 2-9. AM-3349/GRC-106 Terminal Voltage Measurements—Continued

Terminal	Voltage
2A5A2E1	27 dc
2A5A2E2	27 dc
2A5A2R3E1	2,370 dc
2A5A2R3E2	23.7 dc
2A5A2R3E3	-0.6 dc
2A5A3E1	11 dc
2A5A3E2	24 dc
2A5A3E3	24 dc
2A5A3E4	24 dc
2A5A3E5	26.5 ac
2A5A3E6	26.5 ac
2A5A3E7	1.0 dc
2A5A3E8	GND
2A5A3E9	1.0 dc
2A5A3E10	27 dc
2A5A3E11	0
2A5A3E12	0 to +20 dc
2A5A3E13	27 dc
2A5A3E14	20 dc
2A5A3E15	27 dc
2A5A3E16	27 dc
2A5A3E17	27 dc
2A5A3E18	1.0 dc
2A5A3E19	0
2A5A3E20	27 dc
2A5A3E21	27 dc
2A5A3E22	1.0 dc
2A5A4E1	13 dc
2A5A4E2	500 dc

Table 2-9. AM-3349/GRC-106 Terminal Voltage Measurements—Continued

Terminal	Voltage
2A5A4EY	GND
2A5A4E4	600 ac
2A5A4E5	600 ac
2A5A5E1	GND
2A5A5EY	1.0 dc
2A5A5E3	-0.4 dc
2A5A5E4	-0.4 dc
2A5A5E5	-0.4 dc
2A5A5E6	-0.4 dc
2A5A5E7	-0.4 dc
2A5A5E8	GND
2A5A5E9	0
2A5A5E10	0
2A5A5E11	GND
2A5A5E12	23.7 dc
2A5A5E13	23.7 dc
2A5A5E14	0
2A5A5E15	0
2A5A5E16	0
2A5A5E17	0
2A5A5E18	27 dc
2A5A5E19	-0.1 dc
2A5A5E20	GND
2A6A1E1	-0.68 dc
2A6A1E2	6.7 dc
2A6A1E3	25.2 dc
2A6A1E4	27 dc
2A6A1E5	25.2 dc
2A6A1E6	7.2 ac
2A6A1E7 to E8	7 ac
2A6A1E9 to E13	141 ac
2A6A1E10 to E13	55 ac
2A6A1E11 to E13	66 ac
2A6A1E12 to E13	77 ac
2A6A1E14	49 dc
2A6A1E15	-110 dc
2A6A1E16	49 dc
2A6A1E17	GND
2A6A1E18	GND

Table 2-9. AM-3349/GRC-106 Terminal Voltage Measurements—Continued

Terminal	Voltage
2A6A1E19	27 dc
2A6A1E20	GND
2A6A1EY1	GND
2A6A1E22	-110 dc
2A6A1E23 to E25	141 ac
2A6A1E24	-120 dc
2A6A1E26	-120 dc
2A6A1E27	-110 dc

2-15. Turret Assembly 2A2 Filter and Stator Assembly 2A9, Capacitor Programming (fig. 2-12, 4-17, and 4-50)

To isolate a defect in the programming, proceed as follows, using table 2-10.

a. Note the frequency setting of the RT-662/GRC or RT-834/GRC MHz and kHz controls, and determine from table 2-10 the frequency range in which it falls.

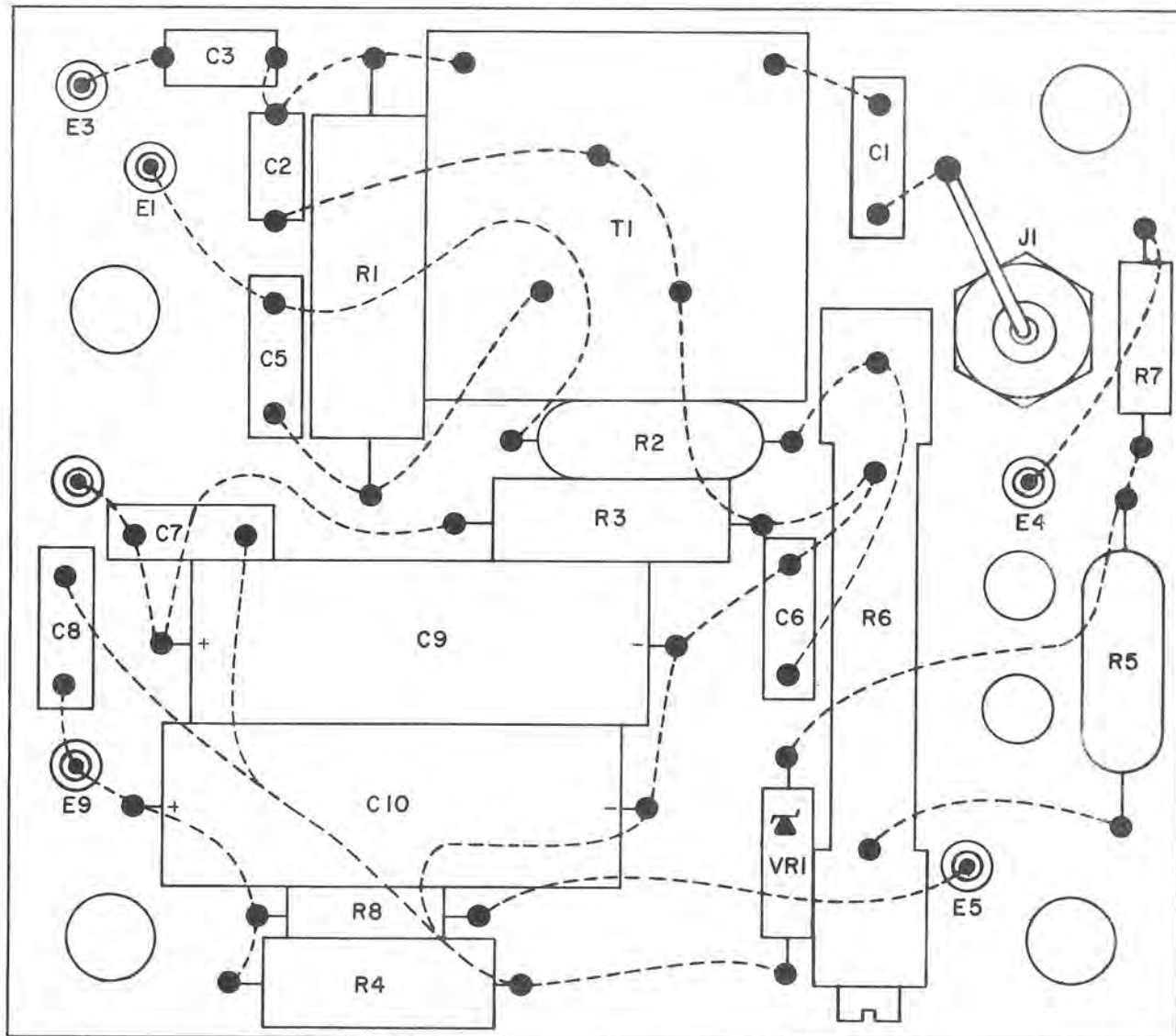

NOTES:

1. CIRCUIT VIEWED FROM SIDE ON WHICH PARTS ARE MOUNTED
2. — PARTS AND PIGTAILS ON FRONT OF BOARD
3. --- WIRING ON BACK OF BOARD

TM 5820-520-35-815

Figure 2-15. Printed circuit board 2A8A1, parts location diagram.

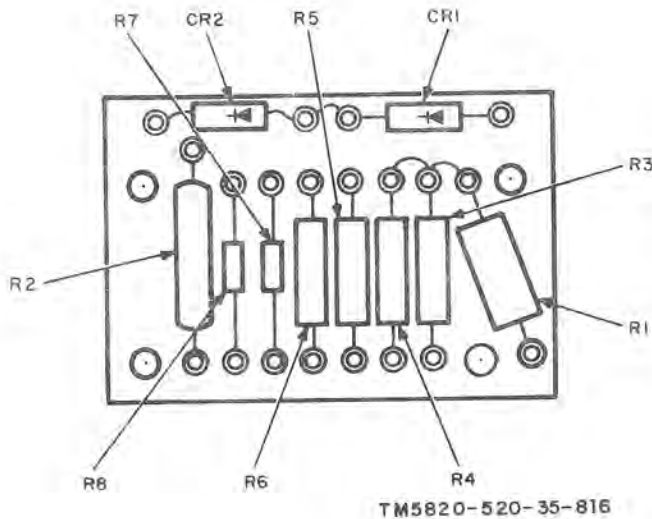

Figure 2-16. Terminal board 2A5A5, parts location diagram.

b. Note the filter being used and set the MHz and kHz controls to a frequency in the 2 to 4 MHz range which will program a different filter into the circuit. If there is now an indication of power output, the filter corresponding to the original setting of the MHz and kHz controls is defective and should be replaced at general support level. If there is still no, or a low, indication of power output, proceed to c below.

c. Set the MHz and kHz controls to a frequency in the 4 to 8 MHz range. If the power output indication is present, proceed to d below. If there is still no, or a low, indication of power output, proceed to e below.

d. Set the MHz and kHz controls to a frequency in the 13 to 14 MHz range. If there is an indication of power output, capacitor 2A9C1 (fig. 4-17) is defective. If there is still no, or a low, indication of power output, section A of capacitor 2A9C2 or its associated stator contacts are defective and should be replaced or repaired.

e. Set the MHz and kHz controls to a frequency in the 8 to 12 MHz frequency range. If there is an indication of power output, proceed

to g below. If there is still no, or a low, indication of power output, proceed to f below.

f. Set the MHz and kHz controls to a frequency in the 16 to 20 MHz frequency range. If there is an indication of power output, section B of capacitor 2A9C2 or its associated stator contacts are defective. If there is still no, or a low, indication of power output, section C of capacitor 2A9C2 or its associated stator contacts are defective.

g. Check capacitor 2A9C3 and associated connections for an obvious defect. If fault is found, make the necessary repairs. If no fault can be found, replace capacitor 2A9C3. If there is still no, or a low, indication of power output, section D of capacitor 2A9C2 or its associated contacts are defective.

Table 2-10. AM-3349/GRC-106 Filter and Capacitor Programming

Frequency range MHz	Turret assembly 2A2 filter in use	Stator assembly 2A9 capacitors in use ^{a,b}					
		C1	C2-A	C2-B	C2-C	C2-D	C3
2-2.5	A1T1	X	X	X	X	X	X
2.5-3	A5T1	X	X	X	X	X	X
3-3.5	A1T2	X	X	X	X	X	X
3.5-4	A5T2	X	X	X	X	X	X
4-5	A11T1	-	-	X	X	X	X
5-6	A11T2	-	-	X	X	X	X
6-7	A13T1	-	-	X	X	X	X
7-8	A13T2	-	-	X	X	X	X
8-9	A12	X	X	X	X	-	-
9-10	A12	-	-	X	X	-	-
10-11	A15	X	X	X	X	-	-
11-12	A15	-	-	X	X	-	-
12-13	A14	X	X	X	X	X	X
13-14	A14	-	X	-	-	-	-
14-15	A2	X	X	-	-	X	X
16-17	A4	X	X	-	X	X	X
17-18	A4	-	-	-	X	X	X
18-19	A6	X	X	-	X	X	X
19-20	A6	-	-	-	X	X	X
20-21	A9	X	X	-	-	X	X
21-22	A9	-	-	-	-	X	X
22-23	A10	X	X	-	-	X	X
23-24	A10	-	-	-	-	X	X
24-25	A3	X	X	-	-	X	X
25-26	A3	-	-	-	-	X	X
26-27	A7	X	X	-	-	X	X
27-28	A7	-	-	-	-	X	X
28-29	A8	X	X	-	-	X	X
29-30	A8	-	-	-	-	X	X

^a X = CAPACITOR IN USE.
^b - = CAPACITOR NOT USED.

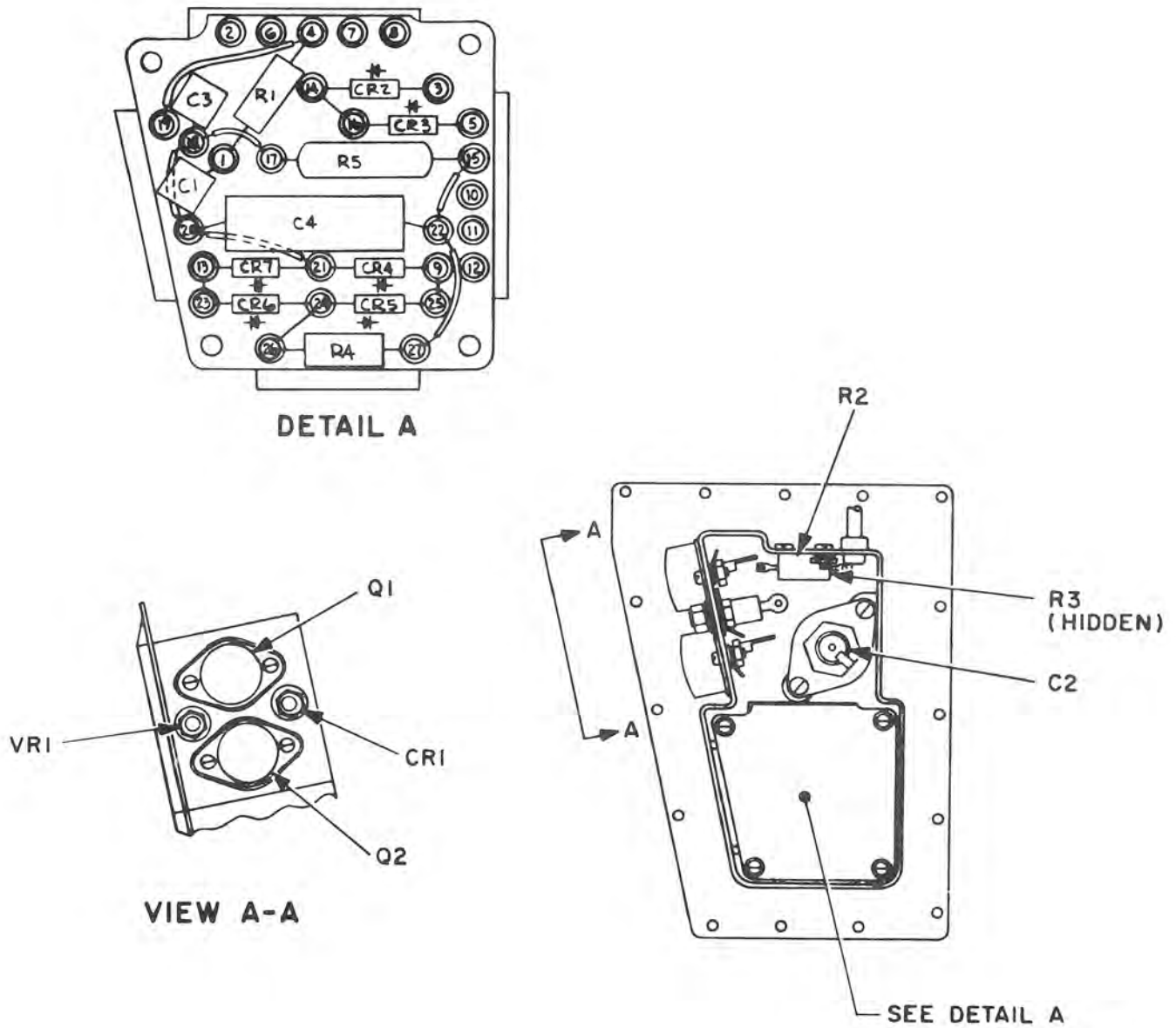

TM5820-520-35-817

Figure 2-17. Dc to ac inverter assembly 2A6A1, parts location diagram.

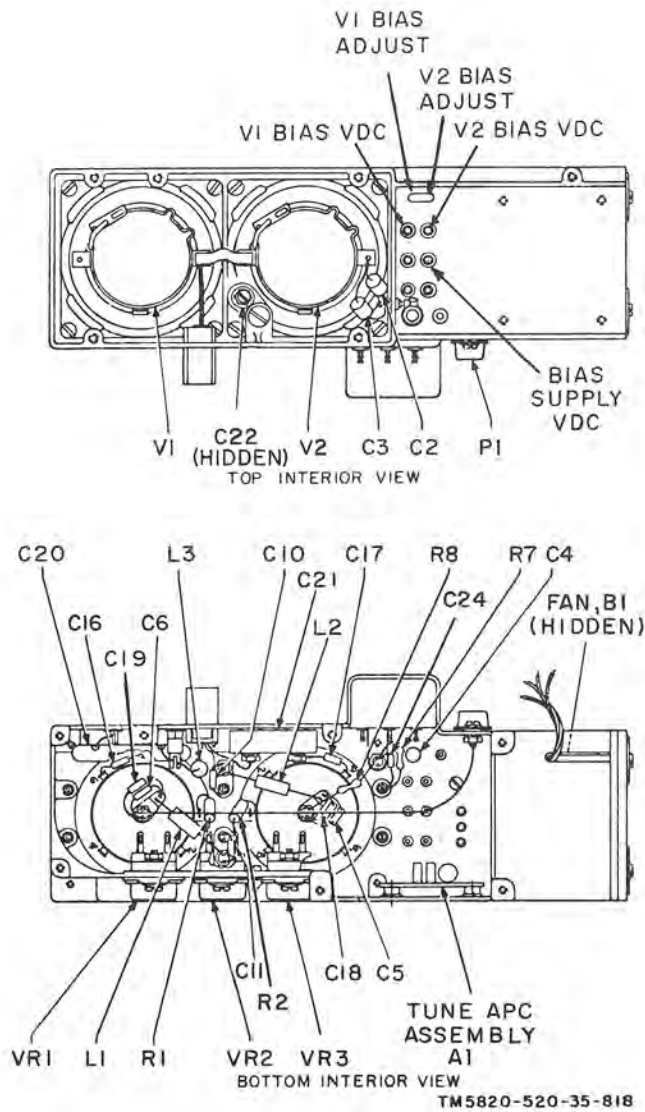
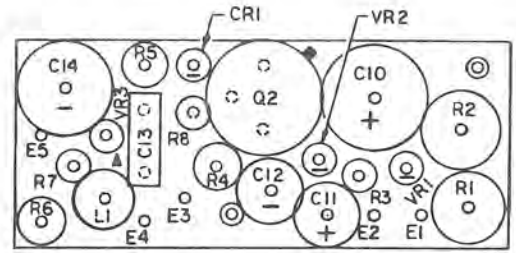
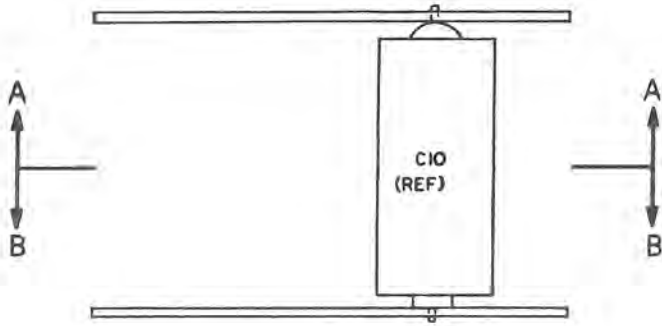
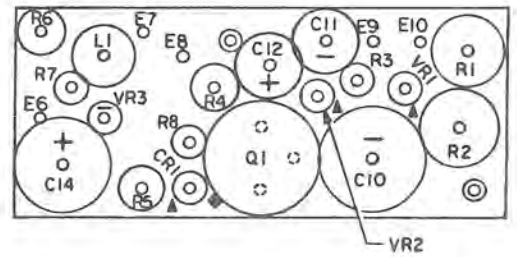

Figure 2-18. Plenum assembly group 2A1A1, parts location diagram.



SECTION A-A



SECTION B-B

TM5820-520-35-819

Figure 2-19. Protection circuit assembly 2A5A7, parts location diagram.

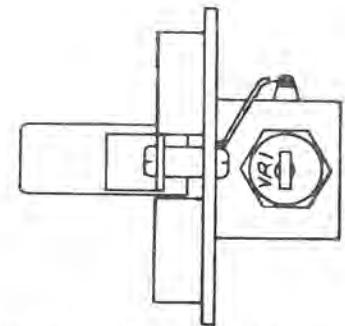
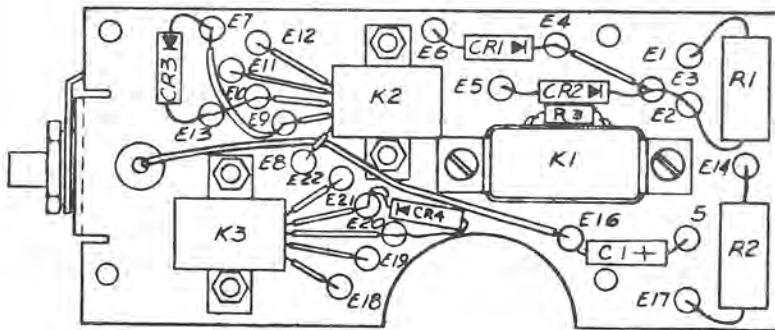

TM5820-520-35-820

Figure 2-20. Plate assembly group 2A5A3, parts location diagram.

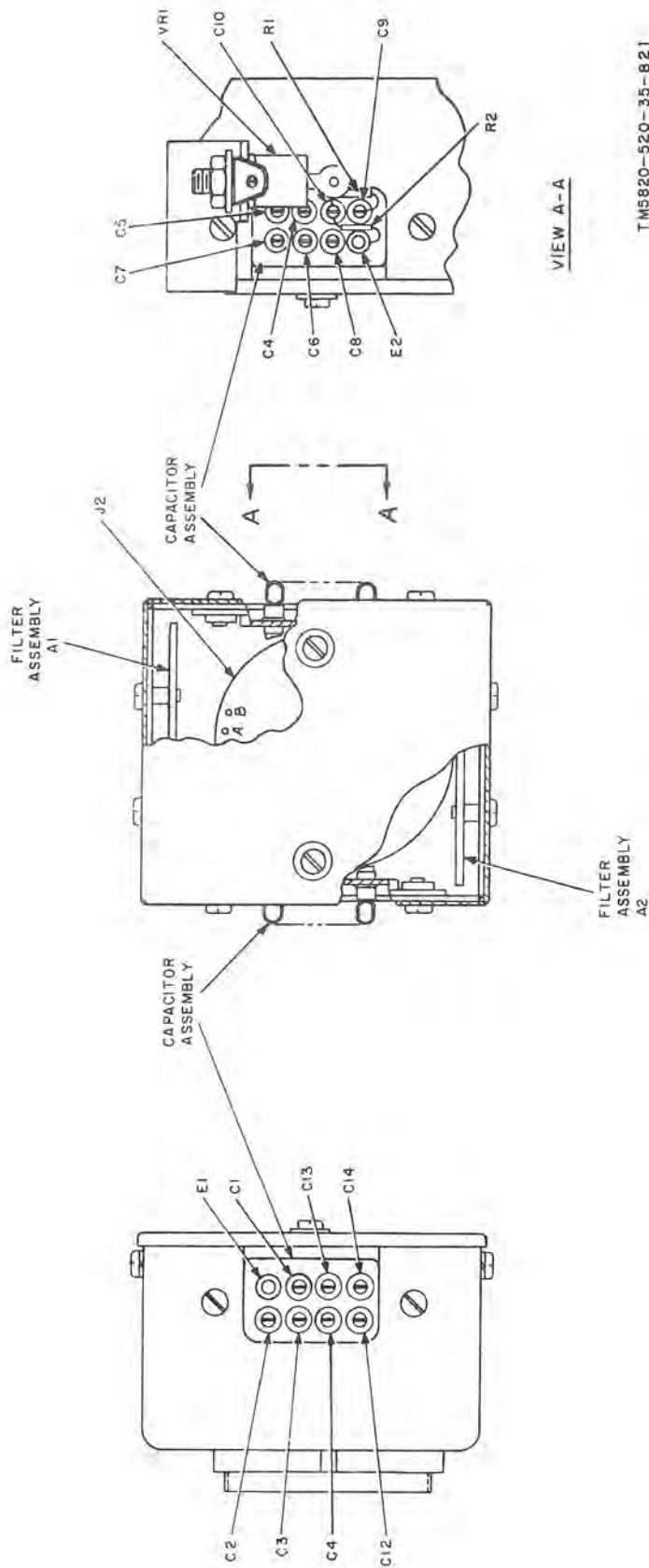

TM5820-520-35-821

Figure 2-21. Filter box assembly 2A5A1, parts location diagram.

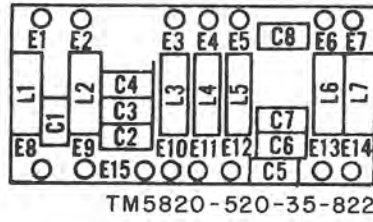
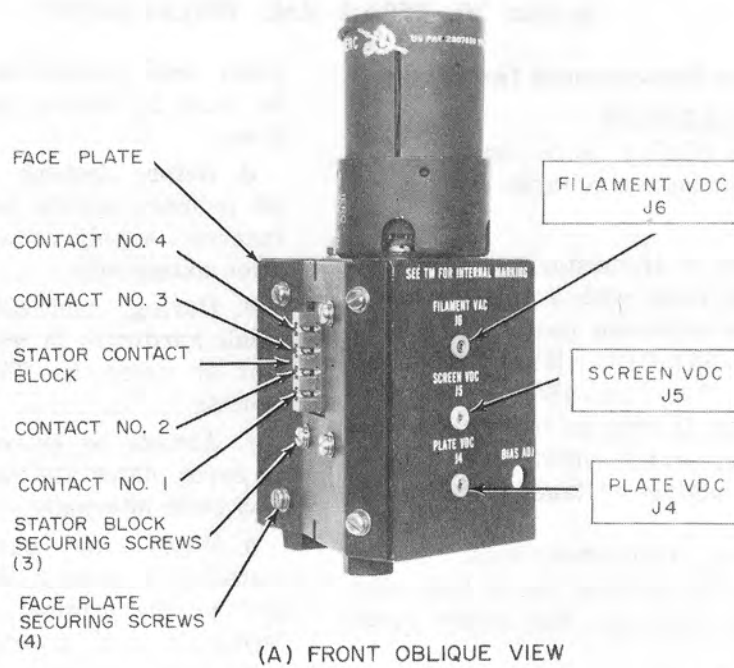
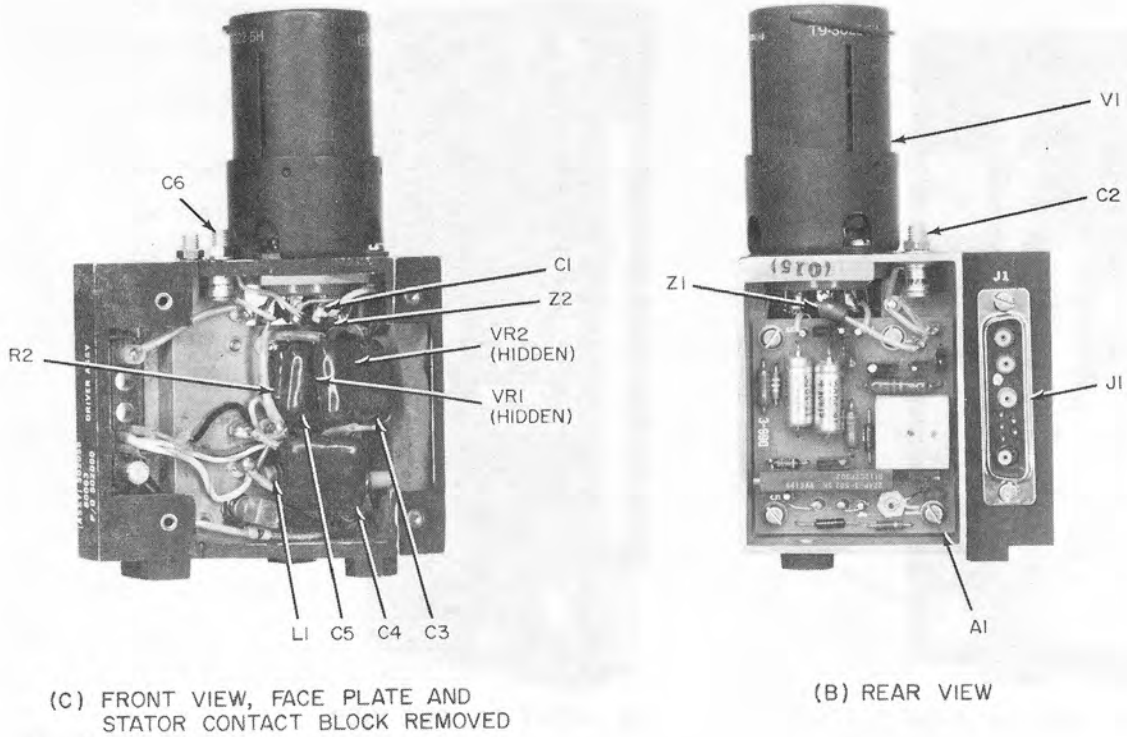

Figure 2-22. Filter box assembly 2A5A1 and 2A5A1A2 parts location diagram.



TM5820-520-35-823

Figure 2-23. Driver assembly 2A8, component location.

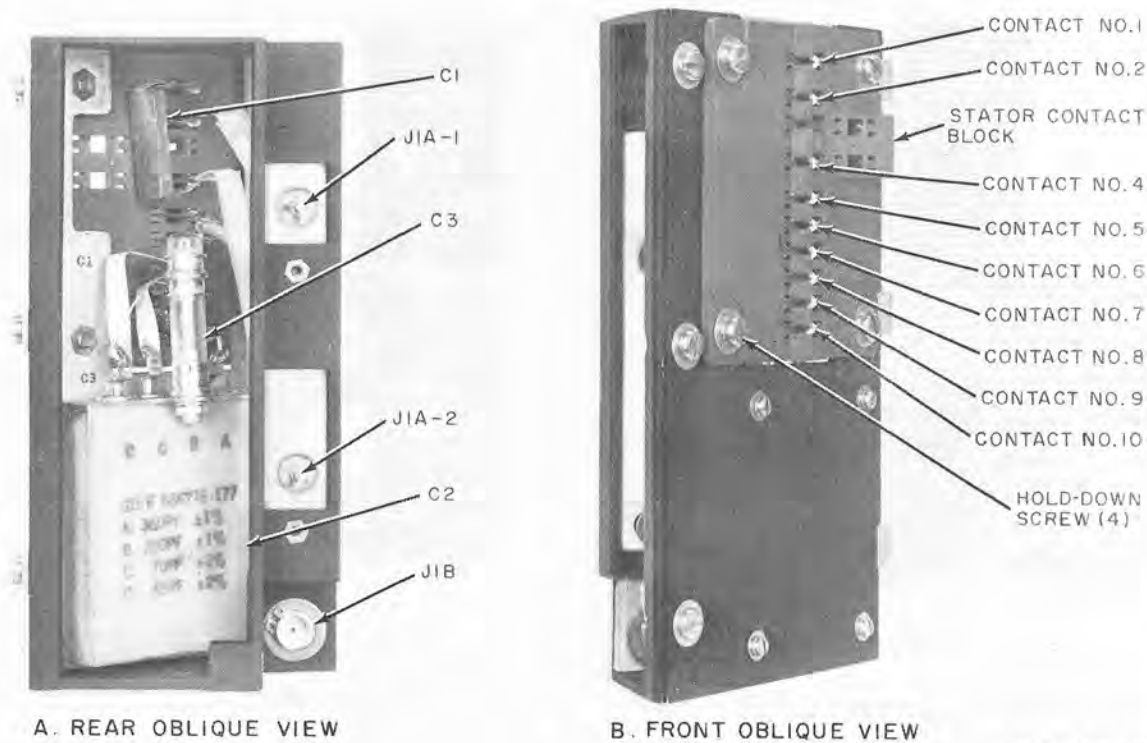

Figure 2-24. Stator assembly 2A9, component location.

TM2820-520-35-824

Section VI. REPAIR AND REPLACEMENT

2-16. General Parts Replacement Techniques

CAUTION

Do not use soldering guns on this equipment as damaging voltages can be induced.

a. This equipment is transistorized. Use only pencil-type soldering irons with a 25 watt maximum capacity when replacing parts in the RT-662/GRC and RT-834/GRC. When replacing parts in the AM-3349/GRC-106, a 60 watt iron will be required. If only ac irons are available, use an isolating transformer. Do not use a soldering gun; damaging voltages can be induced.

b. When soldering transistor leads, solder quickly. Where wiring permits, use a heat sink (long-nosed pliers) between the solder joint and the transistor.

c. Careless or incorrect replacement of parts or repair can cause more damage than the original defect. Before unsoldering parts, note their position. Before unsoldering leads, tag each to insure proper replacement. In circuits with

many lead connections, a simple sketch should be made to insure proper lead connections and dress.

d. Before testing or troubleshooting, check all primary source and power supply voltages. Incorrect supply voltages can affect circuit operation extensively.

e. During mechanical disassembly, gather small hardware in groups corresponding to circuit or assembly. This speeds the reassembly process.

f. Always be extremely careful when covers or cover plates are removed. Dangerous voltages may exist internally.

g. When a new part is installed, it should be installed in exactly the same manner and position as the original. Use the same lead dress, terminals, and ground, and the exact replacement part.

h. After a module is replaced, perform the operating procedures given in TM 11-5820-520-12 to determine that the system is functioning properly.

2-17. Module and Assembly Removal and Replacement for Receiver-Transmitter, Radio RT-662/GRC (fig. 2-25 and 2-26)

CAUTION

Set the SERVICE SELECTOR switch to OFF and disconnect the power source before removing the chassis from the case.

a. Removal of Chassis from Case. Loosen the six captive Allen screws, three located on the top of the control panel and three located on the bottom of the control panel, and slide the chassis forward out of the case.

b. Common Modules. Removal and replacement procedures for frequency standard module 1A3, transmitter IF and audio module 1A5, frequency dividers module 1A6, receiver IF module 1A7, translator module 1A8, receiver audio module 1A10, and dc-to-dc converter and regulator module 1A11 are basically the same. Identification of the modules can be determined by observing the locations of module connectors 1A1XA2 through 1A1XA12 on figure 2-25. These modules are removed and replaced as follows:

(1) Removal.

(a) Set the SERVICE SELECTOR switch at OFF.

(b) Loosen the captive holddown Phillips-head screws (two or four) for the module being replaced.

(c) Pull up on the bail handles to unplug the module from the chassis connector and lift the module out of the chassis.

(2) Replacement.

(a) Set the new or repaired module into the proper place on the main chassis and push down gently to engage the chassis connector. When properly positioned, the module is easily pushed into engagement with the chassis connector.

(b) Secure the module to the chassis by tightening the captive holddown screws. Snap the bail handles down.

c. 100 kHz Synthesizer Module 1A2.

(1) Removal.

(a) Loosen the two captive holddown screws that secure 100 kHz synthesizer module 1A2 (fig. 2-26) to the chassis.

(b) Raise the bail handle and lift the module straight up from the chassis.

(2) Replacement.

(a) Adjust the 100 kHz control of the kHz controls so that the chassis 100 kHz coupler aligns with the coupler of 100 kHz synthesizer module 1A2.

(b) Position module 1A2 in place and gently push down on module while slightly rotating the 100 kHz control back and forth to insure that the coupler is engaged.

(c) Tighten the two captive holddown screws and snap down the bail handle.

d. 10 and 1 kHz Synthesizer Module 1A4.

(1) Removal.

(a) Loosen the two captive holddown screws that secure 10 and 1 kHz synthesizer module 1A4 to the chassis (fig. 2-26).

(b) Raise the bail handle and lift the module straight up from the chassis.

(2) Replacement.

(a) Adjust the 10 kHz and 1 kHz of the kHz controls so that the chassis 10 kHz coupler and 1 kHz coupler are aligned with the respective couplers of 10 and 1 kHz synthesizer module 1A4 (fig. 2-25).

(b) Position module 1A4 in place and gently push down on the module while slightly rotating the 10 kHz and 1 kHz controls to insure that the couplers are engaged.

(c) Tighten the two captive holddown screws and snap down the bail handle.

e. MHz Synthesizer Module 1A9.

(1) Removal.

(a) With power applied to RT-662/GRC or RT-834/GRC, set the SERVICE SELECTOR switch at SSB/NSK. Set the MHz controls at 15 and allow the unit to tune.

(b) Set the SERVICE SELECTOR switch at OFF, disconnect the source power, and remove the chassis from the case.

(c) Loosen the two captive holddown screws that secure MHz synthesizer module 1A9 to the chassis (fig. 2-26).

(d) Raise the bail handle and lift the module straight up from the chassis.

(2) Replacement.

(a) Set the coupler on the bottom of the new or repaired MHz synthesizer module 1A9 at 15 (aligned with index marker on the bottom of the module).

(b) Align the chassis and module couplers (fig. 2-25) and plug the module into chassis connector 1A1XA9.

(c) Tighten the two captive holddown screws and snap down the bail handle.

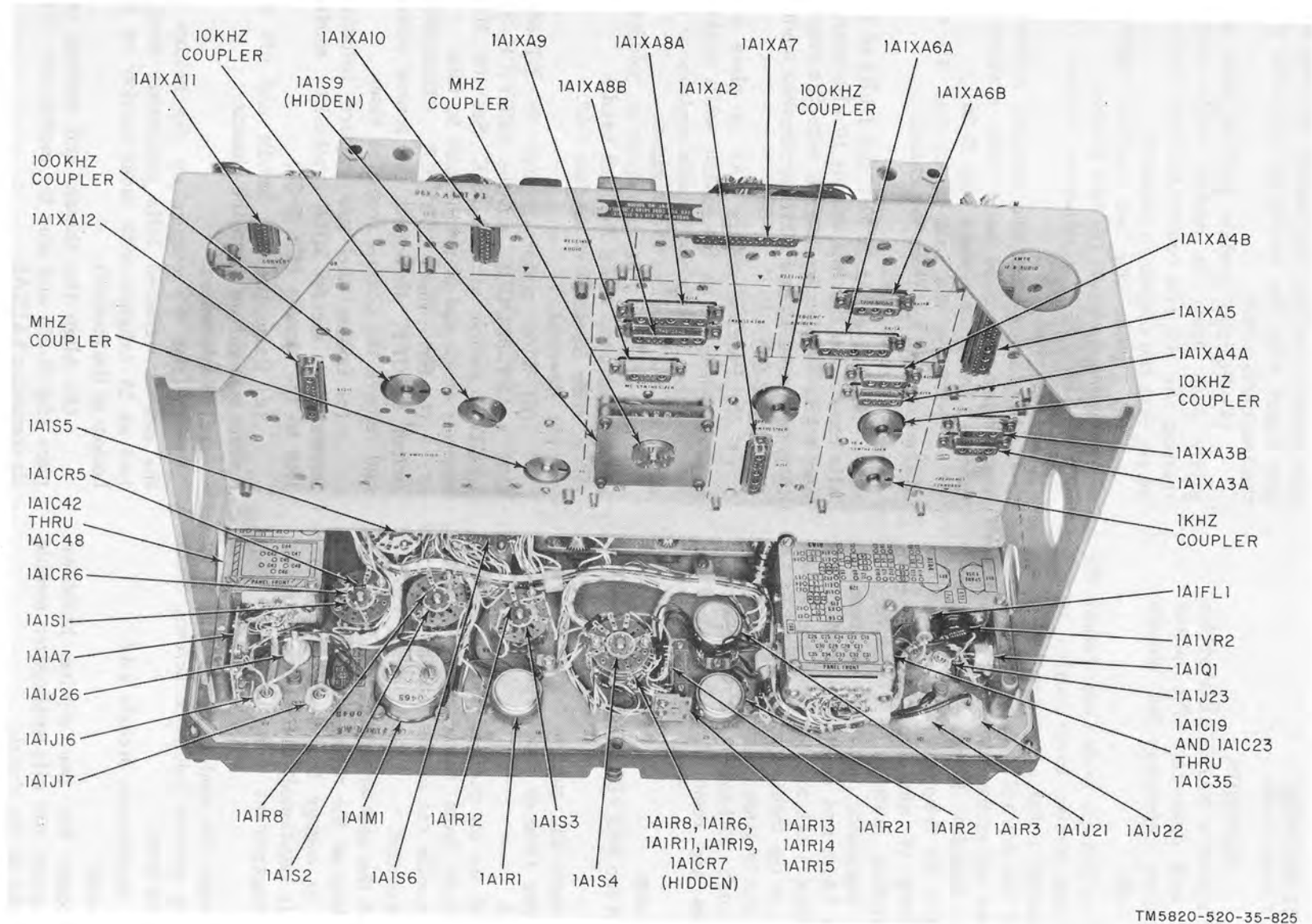

TM5820-520-35-825

Figure 2-25. RT-662/GRC and RT-834/GRC, chassis coupler and connector location.

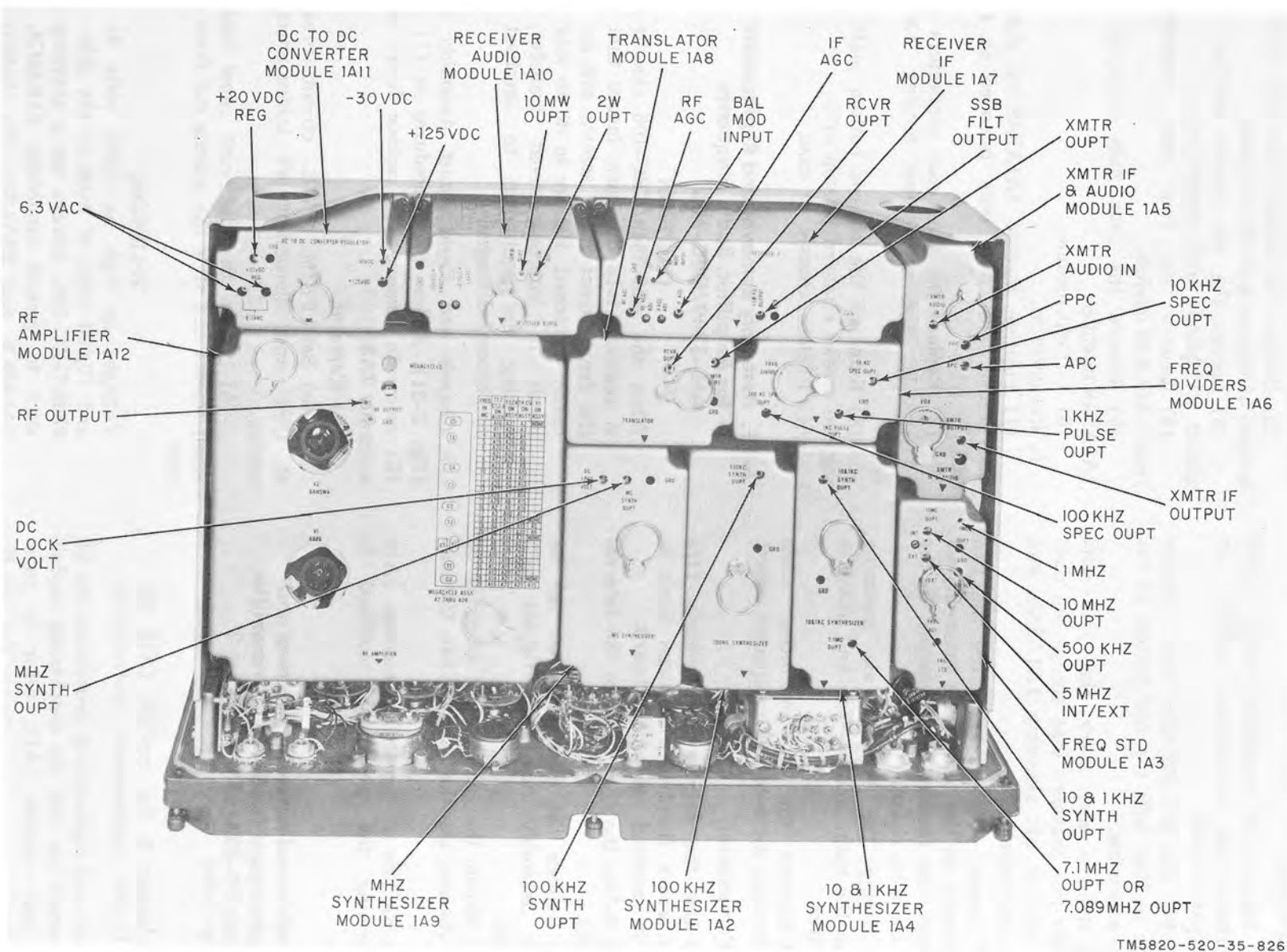

Figure 2-26. RT-662/GRC and RT-834/GRC, module and test point location.

f. Internal Alc Assembly 1A1A2A5 (fig. 2-27 and 2-30).

(1) *Removal.*

(a) Remove rf amplifier module 1A12 by performing the procedures outlined in chapter 3 (para 3-36b).

(b) Set the RT-662/GRC main chassis on its side so that both top and bottom of the chassis are accessible.

(c) Remove and store the two self-locking nuts and washers that secure the dust cover to internal alc assembly 1A1A2A5, and lift off the dust cover.

(d) Locate, remove, and store the two flathead screws on the top of the main chassis which secure the internal alc assembly to the bottom of the main chassis.

(e) Swing the internal alc assembly away from the main chassis. Tag and unsolder the five wires.

(f) Remove the two mounting studs from the internal alc assembly component board.

(2) *Replacement.*

(a) Use the original two screws ((f) above) to secure the two mountings studs to the new or repaired component board.

(b) Solder the five wires to the internal alc assembly.

(c) Replace the dust cover on the internal alc assembly; use the original self-locking nuts.

(d) Mount the internal alc assembly on the main chassis; use the original two flathead screws.

(e) Replace rf amplifier module 1A12 by performing the procedures outlined in chapter 3.

2-18. Module and Assembly Removal and Replacement for Receiver-Transmitter, Radio RT-834/GRC
(fig. 2-30)

NOTE

See chapter 3 for module 1A12 removal and replacement instructions.

For removal and replacement procedures for all modules except the 100 Hz synthesizer module 1A1A2A8 and module 1A12, refer to paragraph 2-17. To remove and replace the 100 Hz synthesizer module 1A1A2A8, proceed as follows:

a. Removal.

(1) Take the RT-834/GRC chassis out of the case.

(2) Remove the screws from the plate on bottom of chassis and lift off plate.

(3) Loosen the two screws holding connector 1A1A2AJ1 and remove plug.

(4) Remove the four coax connectors from 1A1A2A8 module.

(5) Remove the four nuts securing the 1A1A2A8 module.

(6) Lift out module.

b. Replacement.

(1) Position module 1A1A2A8 on chassis and secure with four nuts removed in step a(5).

(2) Replace the four coax connectors and 1A1A2A8J1, tighten screws holding 1A1A2A8J1.

(3) Reinstall the chassis bottom plate using the screws removed in step a(2).

(4) Replace chassis in case.

2-19. Assembly Removal and Replacement for Amplifier, Radio Frequency AM-3349/GRC-106

CAUTION

When the AM-3349/GRC-106 chassis is replaced into the case, insure that the front panel Allen screws are securely tightened. Failure to do so may result in improper heat transfer, causing the equipment to overheat and become damaged.

a. Chassis and Front Panel Assembly 2A5 (fig. 2-31). Follow the procedures in (1) and (2) below to remove and replace front panel assembly 2A5.

(1) *Removal.*

(a) Set PRIM. PWR. circuit breaker at OFF and disconnect all interconnecting cables.

(b) Loosen the six front panel captive Allen screws and slide the chassis out from the case.

WARNING

Voltages as high as 3,000 volts dc and 10,000 volts rf exist in the AM-3349/GRC-106. Always use a shorting stick to ground capacitors 2A5A2C4, 2A5A2C5, and 2A5A2C6 (fig. 2-34), and pin A or B of PRIM. POWER connector 2A5J7 (fig. 2-33) before touch-

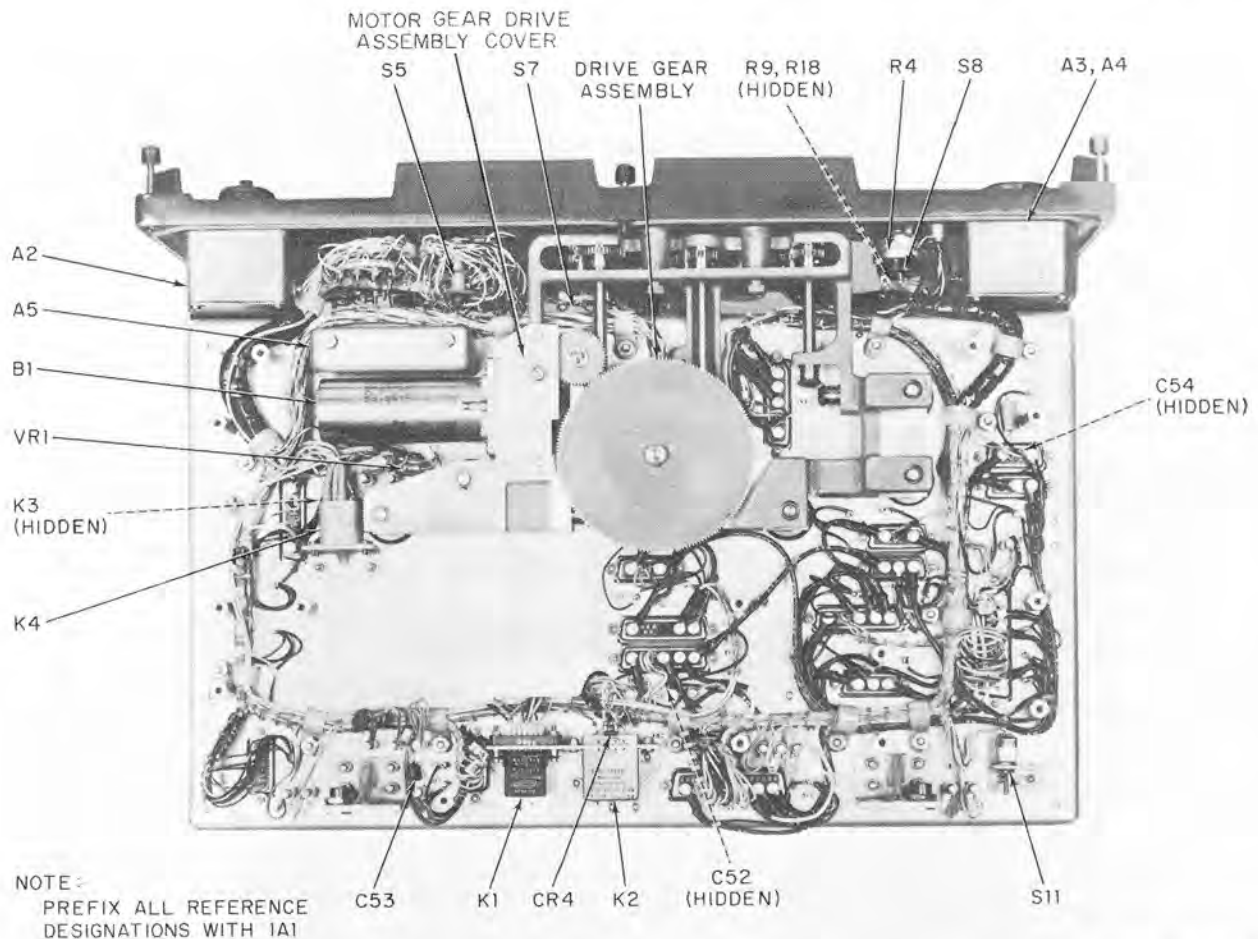

Figure 2-27. Receiver-Transmitter, Radio RT-662/GRC and RT-834/GRC parts location, bottom view.

ing components. Wait 15 seconds before shorting capacitors 2A5A2C5 and 2A5A2C6 to prevent damage to capacitor 2A5A2C6.

(c) Remove the four screws that secure antenna coupler module 2A3 cover and remove the cover.

(d) Rotate the ANT. LOAD control to the high end (955) and the ANT. TUNE control to the high end (618).

(e) Back off the ANT. LOAD control and the ANT. TUNE control slightly, until the slots in the mechanical couplings to antenna coupler module 2A3 are vertical.

(f) Remove the 11 screws (fig. 2-32) that secure front panel assembly 2A5 to the chassis. These screws (three on the left side, three on the right side, and five on the bottom) pass through the chassis from the outside into the front panel casting.

(g) Pull the front panel straight forward away from the chassis.

(2) Replacement.

(a) Rotate the ANT. LOAD control to the high end (955) and the ANT. TUNE control to the high end (618) on the new or repaired front panel assembly.

(b) Adjust the ANT. LOAD and the ANT. TUNE controls slightly, until the slots in the mechanical couplings to antenna coupler module 2A3 are vertical.

(c) Hold the front panel in front of the chassis, and gently push into position. Determine that connector 2A5J1 (fig. 2-33) mates properly with connector 2A1P5, and that the mechanical couplings to antenna coupler assembly 2A3 are properly engaged.

(d) Replace the 11 original screws (three along each side, and five along the bottom).

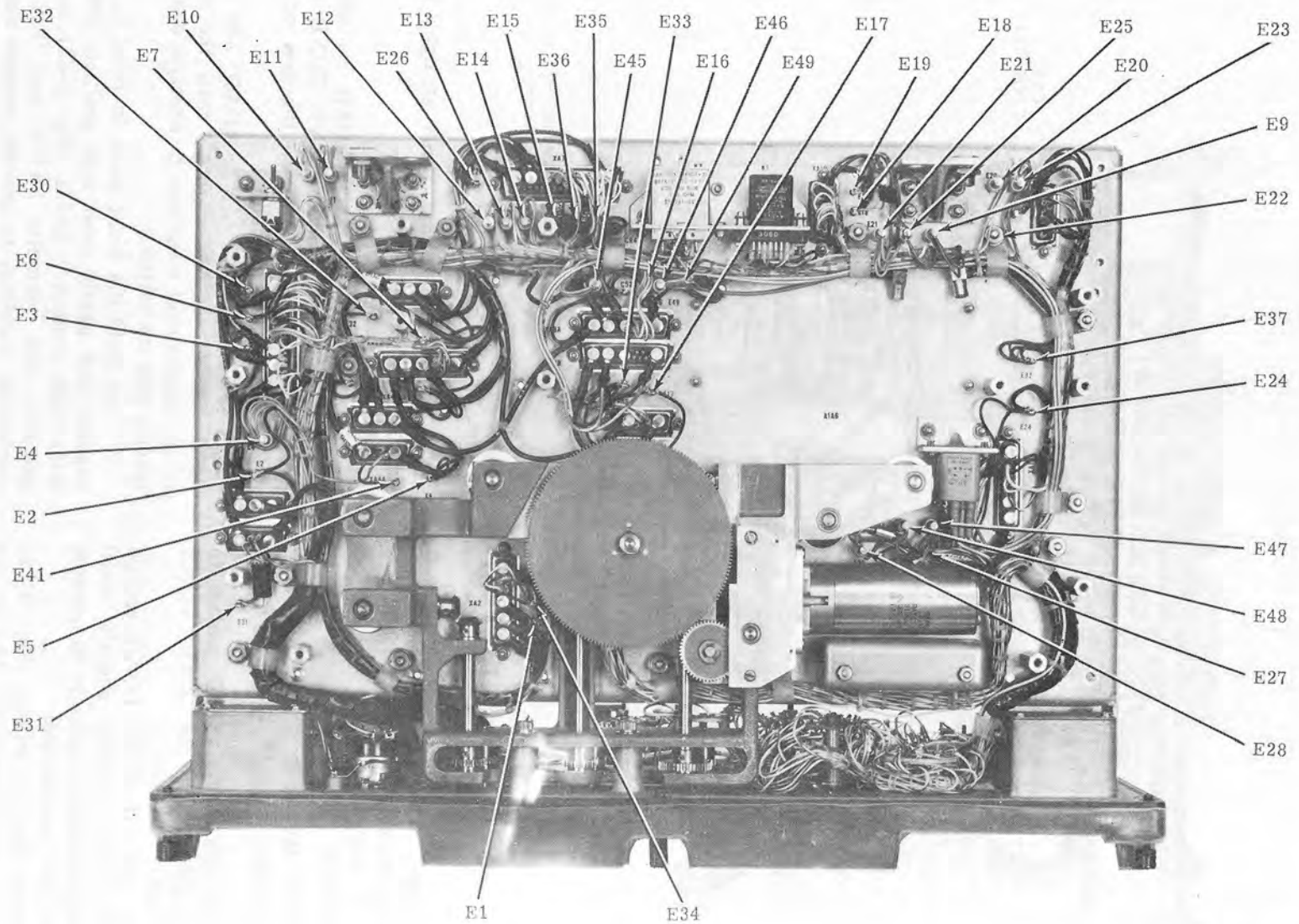

TM5820-520-35-828

Figure 2-28. Receiver-Transmitter, Radio RT-662/GRC and RT-834/GRC, chassis terminal locations.

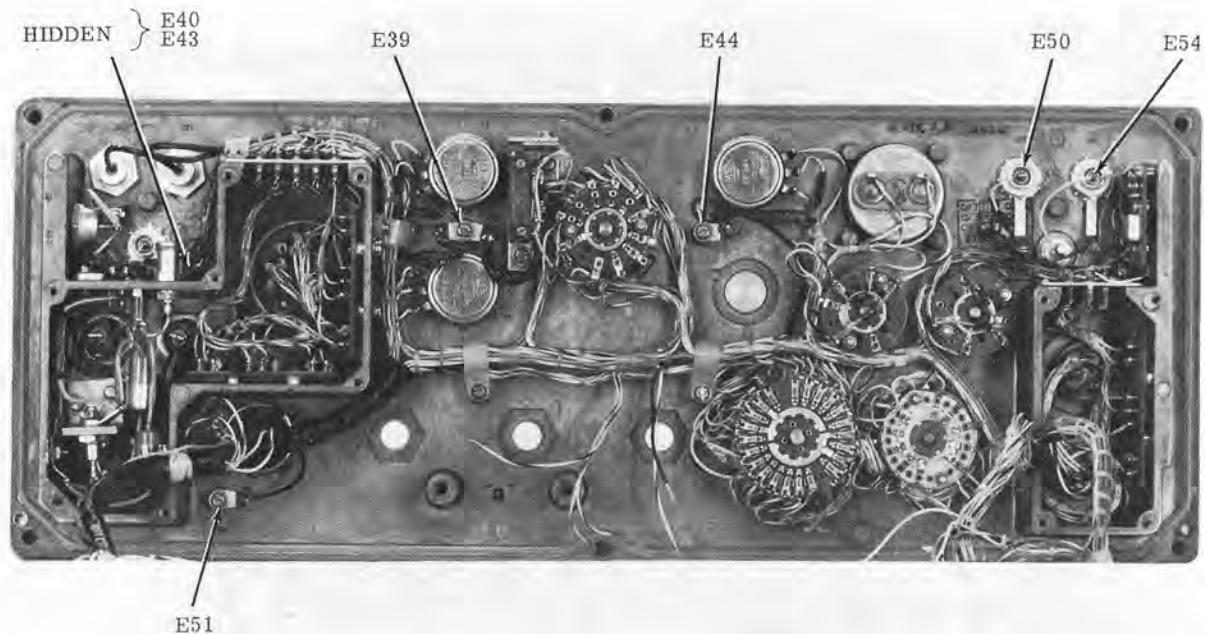

TM5820-520-35-829

Figure 2-29. Receiver-Transmitter, Radio RT-662/GRC and RT-834/GRC, front panel terminal locations.

(e) Replace antenna coupler assembly 2A3 cover with the four original screws.

(f) Slide the chassis back into the case, tighten the front panel Allen screws, and reconnect all interconnecting cables.

b. *Dc-to-Ac Inverter Assembly 2A6A1* (fig. 2-17). The assembly is located at the left-rear corner on the top of the AM-3349/GRC-106 case.

(1) *Removal.*

(a) Set PRIM. PWR. circuit breaker at OFF.

(b) Remove the 15 screws that secure dc-to-ac inverter assembly 2A6A1 plate and lift the assembly way from the case.

(c) Loosen the two screws that secure connector 2A6A1P1.

(d) Disengage connector 2A6A1P1 from connector 2A6J1, and remove the assembly.

(2) *Replacement.*

NOTE

Before replacing the assembly, inspect the gasket which forms the watertight seal between the dc-to-dc inverter assembly and the case. If the gasket is damaged, replace it.

(a) Plug connector 2A6A1P1 into connector 2A6J1, and engage and tighten the two securing screws on the connector.

(b) Position the new or repaired dc-to-ac inverter assembly 2A6A1 in place and replace the 15 original screws that secure the assembly to the case.

c. *Antenna Coupler Assembly 2A3* (fig. 2-31, 2-32, 2-36, and 2-37).

(1) *Removal.*

(a) Set PRIM. PWR. circuit breaker at OFF and disconnect all interconnecting cables.

(b) Loosen the six front panel Allen screws and slide the chassis out from the case.

WARNING

Voltages up to 3,000 volts dc and 10,000 volts rf exist in the AM-3349/GRC-106. Always use a shorting stick to ground capacitors 2A5A2C4 and 2A6A2C5 (fig. 2-33), and pin A or B of PRIM POWER connector 2A5J7 before touching any components. Wait 15 seconds after turning off set before shorting capacitors in section 2A5 so as to prevent damage to capacitor 2A5A2C6.

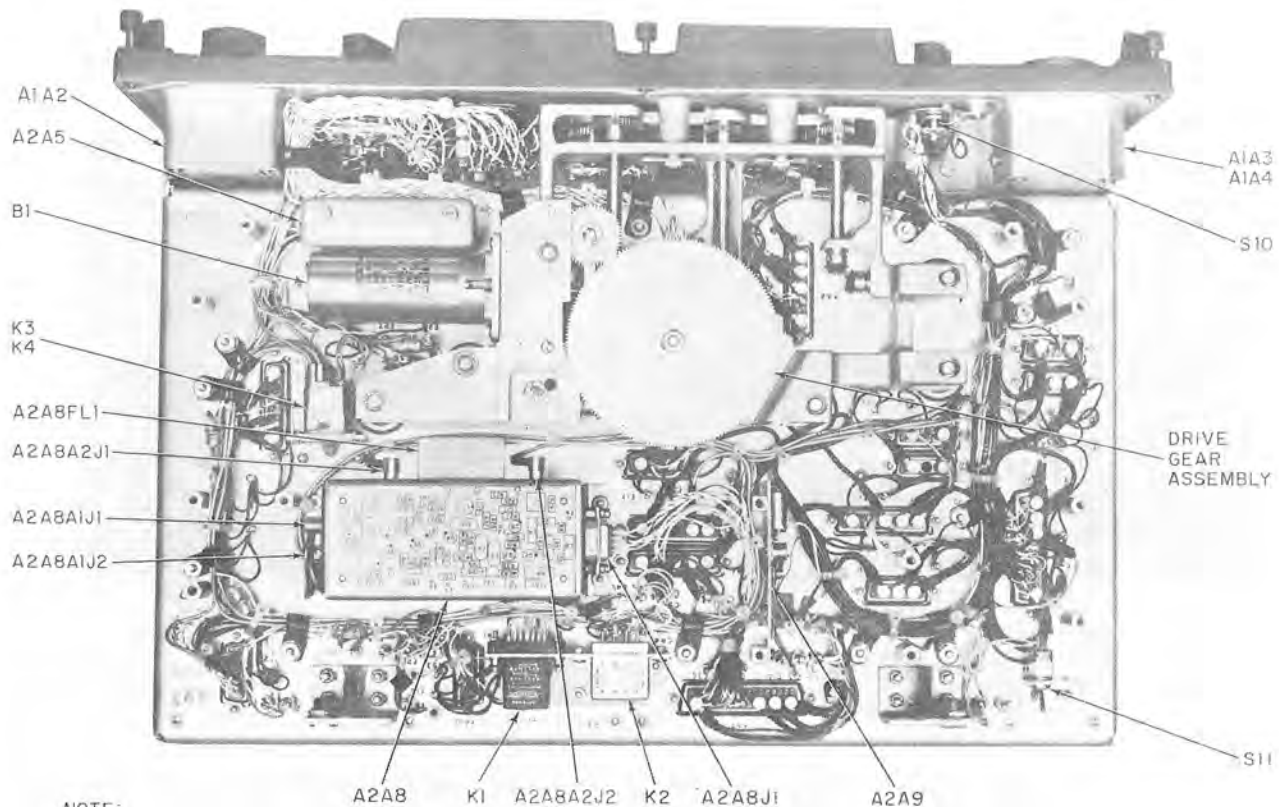

NOTE:
PREFIX ALL REFERENCE
DESIGNATIONS WITH 1A1.

TM5820-520-35-830

Figure 2-30. Receiver-Transmitter, Radio RT-834/GRC, parts location, bottom view.

(c) Remove the four screws that secure antenna coupler assembly 2A3 cover and remove the cover.

(d) Rotate the front panel ANT. LOAD control to the high end (counter indicates 955).

(e) Rotate the front panel ANT. TUNE control to the high end (counter indicates 618).

(f) Observe the mechanical coupling shafts to the antenna coupler assembly, and turn the front panel ANT. LOAD and ANT. TUNE controls until the slots in the shafts are vertical.

(g) Tilt the chassis up and loosen the bottom four captive screws that secure antenna coupler assembly 2A3 to the chassis and then set the chassis flat in its normal operating position.

CAUTION

Extreme care must be taken when performing the following steps so that vacuum relay 2A5K1 and other components on the front panel will not be damaged.

(h) Carefully lift antenna coupler assembly 2A3 straight up from the chassis.

(2) Replacement.

(a) Insure that the front panel ANT. TUNE control is set at the high end (counter indicates 618).

(b) Insure that the front panel ANT. LOAD control is set at the high end (counter indicates 955).

(c) Turn the ANT. TUNE and the ANT. LOAD controls so that the slots in the mechanical coupling shafts to the antenna coupler assembly are vertical.

(d) On the new or repaired antenna coupler assembly 2A3, rotate vacuum capacitor 2A3C26 shaft counterclockwise until the collar just becomes loose. Then rotate the shaft one-fourth turn clockwise.

(e) On the new or repaired antenna coupler assembly 2A3, rotate coil 2A3L1 shaft counterclockwise until the contact is at the end of the first turn of wire. The contact and the motion of the contact can be seen by looking into

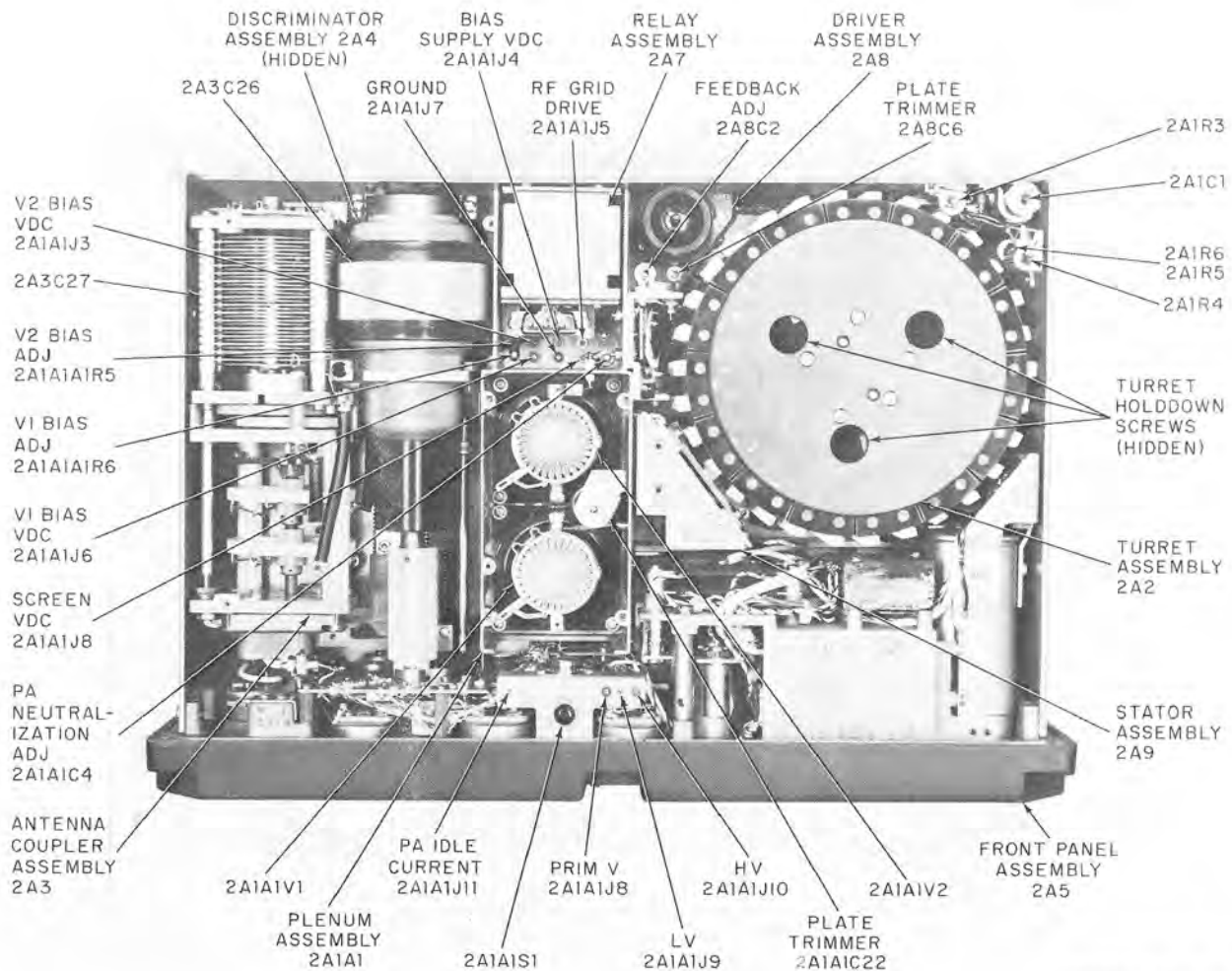

TM5820-520 35-831

Figure 2-31. Amplifier, Radio Frequency AM-3349/GRC-106, component location, top view.

the end of coil 2A3L1 (front panel end) while rotating the shaft slightly. The slot in the shaft coupling should be vertical in the final setting.

CAUTION

Extreme care must be taken when performing the following procedures, so that vacuum relay 2A5K1 on the front panel will not be damaged.

(f) Carefully set the new or repaired antenna coupler assembly straight down on the main chassis so that connector 2A3J1 properly mates with 2A1XA3.

(g) Tilt the chassis up so that the bottom is accessible, and secure the assembly to the main chassis with the four captive screws.

(h) Set the chassis down and replace the antenna coupler cover; use the four original screws.

(i) Slide the chassis back into the case, tighten the front panel Allen screws, and reconnect all interconnecting cables.

d. *Discriminator Assembly 2A4* (fig. 2-31 and 2-32).

(1) *Removal.*

(a) Remove antenna coupler module 2A3 by performing the procedure given in c(1) above.

(b) Tilt the chassis up and remove the four screws (3, fig. 2-32) that secure discriminator assembly 2A4 to the chassis.

(c) Set the chassis down, disconnect connectors 2A4J1 (located on front panel of dis-

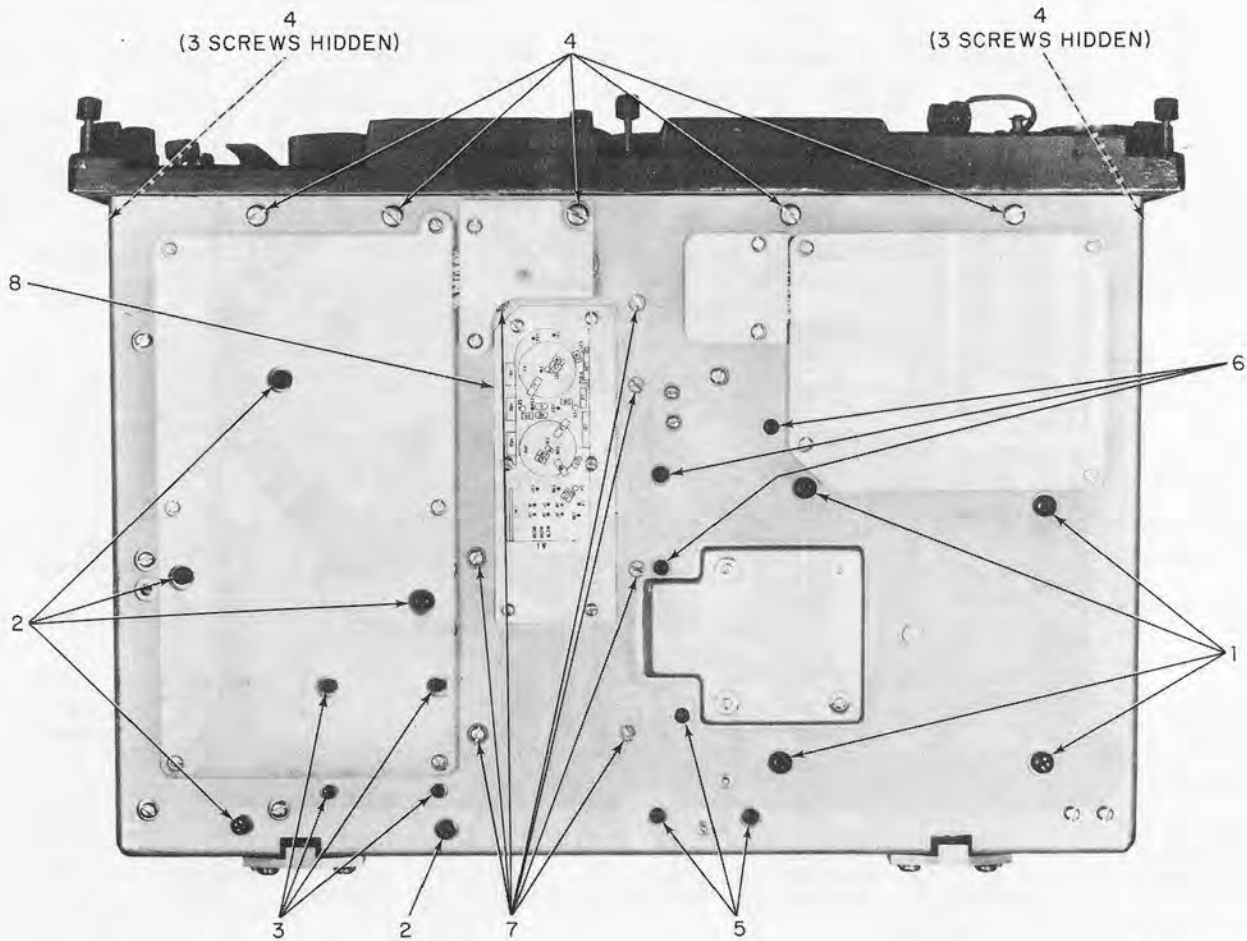

TM5820-520-35-832

- | | |
|--|---|
| 1. Turret assembly 2A2, turret base holddown screws. | 5. Driver assembly 2A8 holddown screws. |
| 2. Antenna coupler assembly 2A3 holddown screws. | 6. Stator assembly 2A9 holddown screws. |
| 3. Discriminator assembly 2A4 holddown screws. | 7. Plenum assembly 2A1 holddown screws. |
| 4. Front panel assembly 2A5 holddown screws. | 8. Plenum assembly 2A1 cover (plenum parts location). |

Figure 2-32. Amplifier Radio Frequency, AM-3349/GRC-106, component location, bottom view.

criminator assembly 2A4 casing) and 2A4J2 (located on the top panel of 2A4 casing), and lift out the assembly.

(2) Replacement.

(a) Set the assembly in place and connect connectors 2A4J1 and 2A4J2 on the new or repaired discriminator assembly.

(b) Tilt the chassis up and replace the four original screws that secure the assembly to the chassis.

(c) Replace the antenna coupler assembly by performing the procedure given in c(2) above.

e. Driver Assembly 2A8 (fig. 2-31 and 2-32).

(1) Removal.

(a) Remove turret drum assembly 2A2 by performing the procedure given in chapter 3 (para 3-36b).

(b) Tilt the chassis up and remove the three screws (5, fig. 2-32) that secure driver assembly 2A8 to the chassis. Remove turret base assembly unit.

(c) Set the chassis down, slide the assembly away from the plenum wall to disengage the connectors 2A8J1 on assembly and 2A1A-1XA8 on plenum wall, and lift out the assembly.

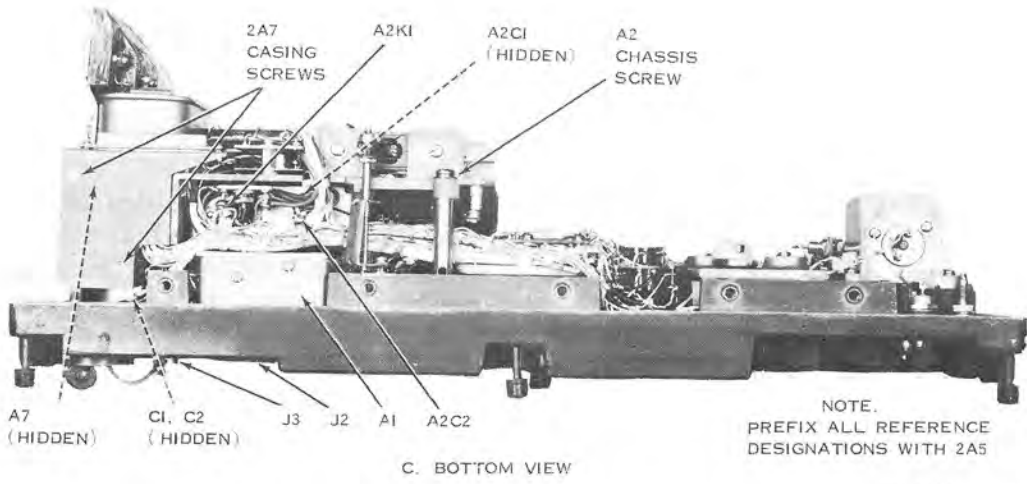
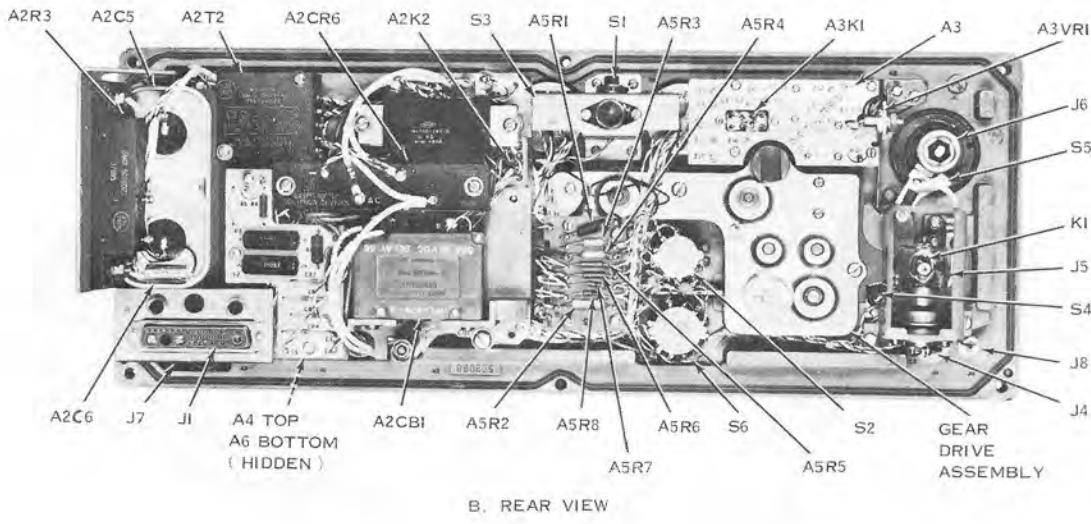
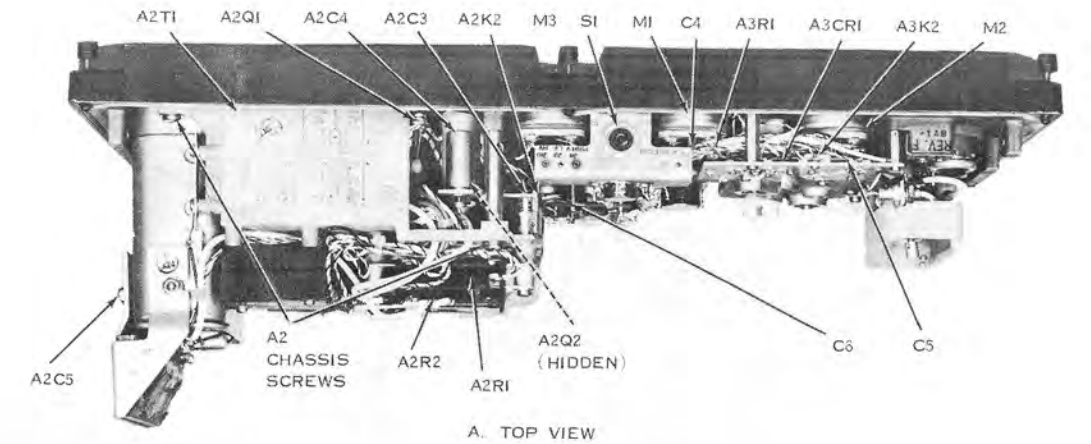

NOTE.
PREFIX ALL REFERENCE
DESIGNATIONS WITH 2A5

Figure 2-33. AM-3349/GRC-106, Front panel assembly 2A5, component location.

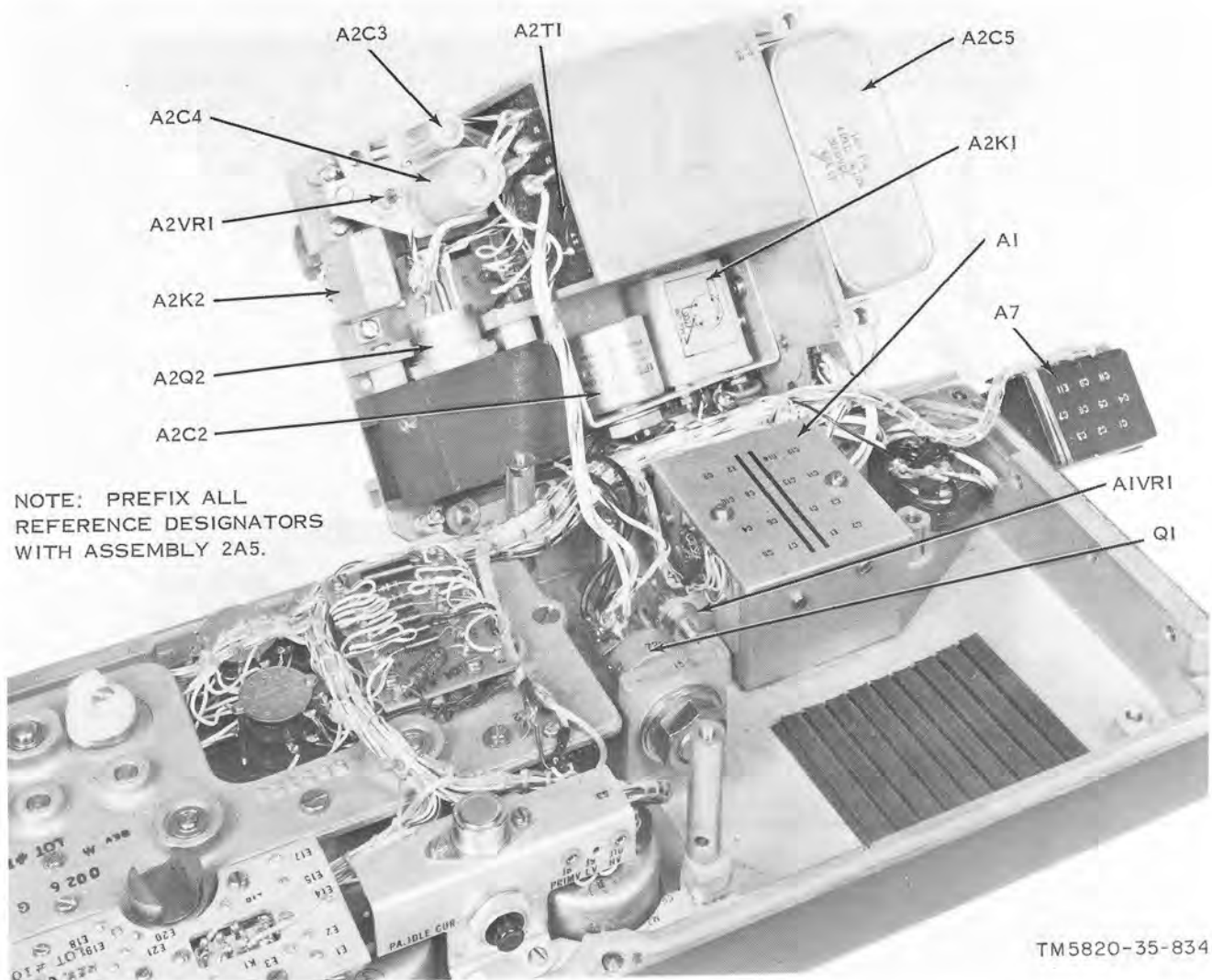

TM5820-35-834

Figure 2-34. AM-3349/GRC-106, Front panel assembly 2A5 with dc-to-dc converter assembly 2A5A2 removed.

(2) Replacement.

(a) Set the new or repaired driver assembly 2A8 in place so that connector 2A8J1 engages the connector 2A1A1XA8 on the plenum wall, and firmly press the assembly into place.

(b) Tilt the chassis up and replace the three original screws that secure the assembly to the chassis.

(c) Replace the turret drum assembly as outlined in paragraph 3-36.

f. Dc-to-Dc Converter Assembly 2A5A2 (fig. 2-34).

(1) Removal.

(a) Remove front panel assembly 2A5 from the chassis by performing the procedures given in a(1) above and set the front panel as-

sembly in a controls down position (C, fig. 2-33).

(b) Note the position of the screws, the washers, and the spacer that hold down resistors 2A5A2R1 and 2A5A2R2 (A, fig. 2-33), and remove the screws, the washers, and the spacers; push the resistors aside and remove the 2A5A2 chassis screw.

(c) Remove the other 2A5A2 chassis screw (A, fig. 2-33) and the 2A5A2 chassis screw (C, fig. 2-33).

(d) Remove the two 2A5A7 casing screws (C, fig. 2-33).

(e) Remove protection assembly 2A5A7 (fig. 2-35) with the leads attached and set it aside.

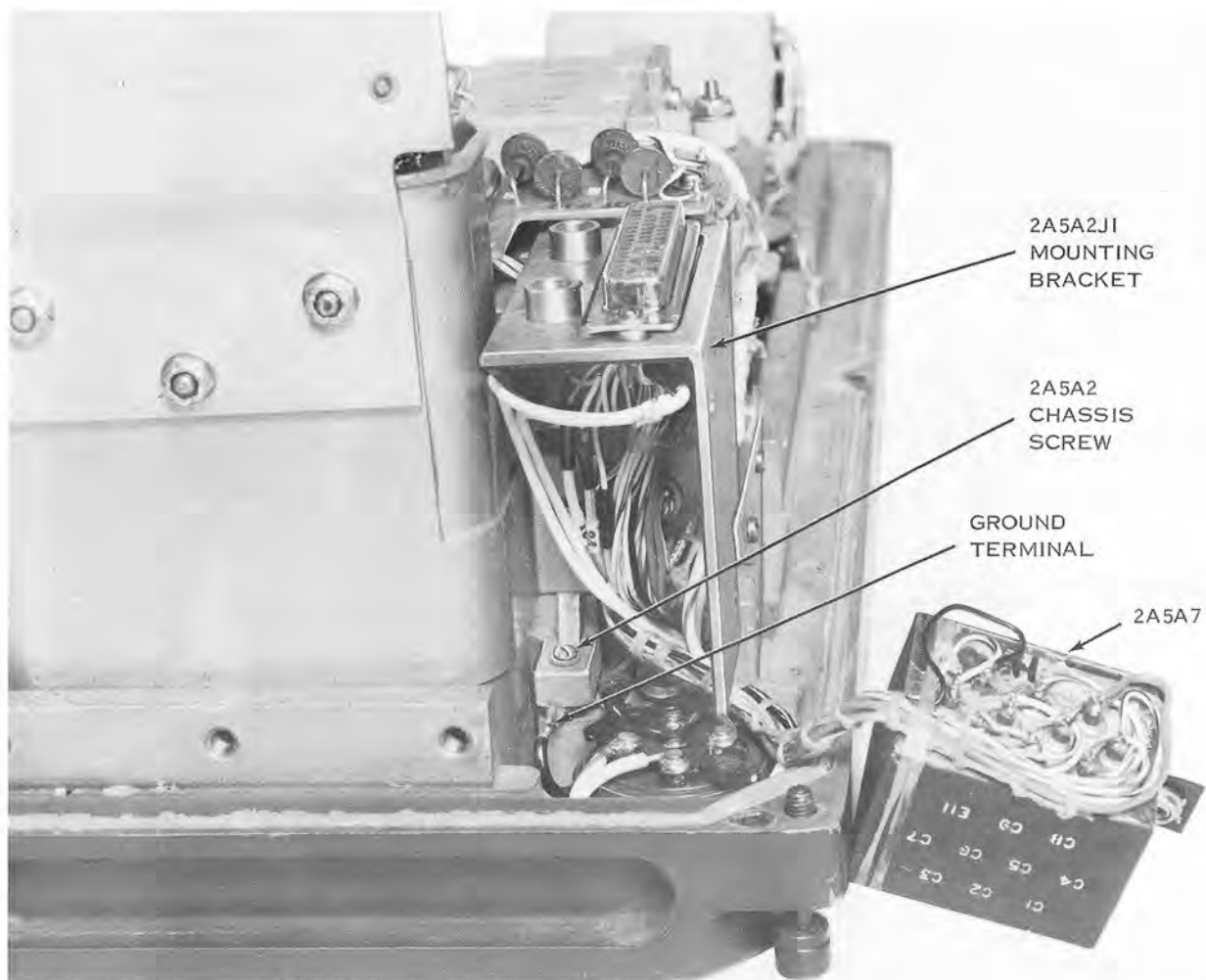

TM5820-520-35-835

Figure 2-35. AM-3349/GRC-106, Front panel assembly 2A5, with protection assembly 2A5A7 removed.

(f) Remove the 2A5A2 chassis screw and washer (fig. 2-35) with an offset screwdriver, or with a straight shanked screwdriver inserted through a hole on the top center of the 2A5A2J1 mounting bracket. The hole does not exist on early model equipments. For replacement purposes, note the position of the ground terminal (fig. 2-35) secured by the 2A5A2 chassis screw.

CAUTION

Do not place unnecessary stress on the harnessed cable.

(g) Position front panel assembly 2A5 so that the end of the assembly that contains dc-to-dc converter assembly 2A5A2 is facing you. Lift dc-to-dc converter assembly 2A5A2

a small distance in an upward direction (only enough to clear the mounting studs) and, assuming a hinge action on the lower right side of assembly 2A5A2, turn it clockwise carefully so as not to exert any great stress on the connecting cables and place it next to the front panel (fig. 2-34). Assembly 2A5A2, because of cable harnesses on early modules, may not turn enough to rest on the bench; however, it will turn enough so that all components under assembly 2A5A2 can be reached for replacement.

(2) Replacement.

(a) Position front panel assembly 2A5 so that the end of the assembly that holds dc-to-dc converter assembly 2A5A2 is facing you and assembly 2A5A2 is to the right of the front panel. Make sure that no leads are pinched or

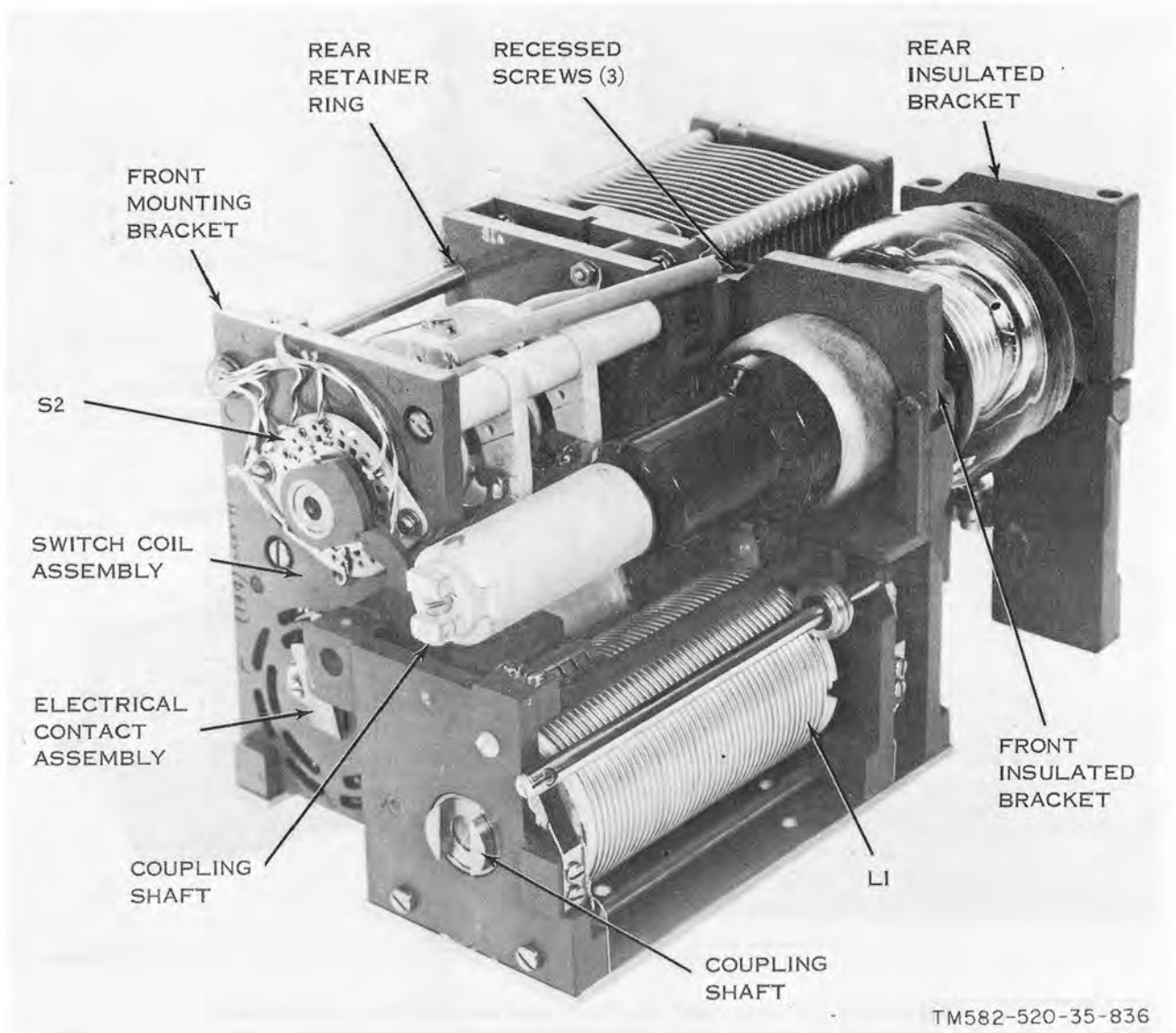

Figure 2-36. Antenna coupler assembly 2A3, parts location, front oblique view.

pushed away from their correct positions, and rotate assembly 2A5A2 counterclockwise into a position where the converter chassis mounting holes are keyed to the front panel chassis mounting holes. Make sure that the ground terminal (fig. 2-35) is in the correct position ((1)(f) above).

(b) Replace the four 2A5A2 chassis screws (fig. 2-35, and A and C, fig. 2-33).

(c) Insert protection assembly 2A5A7 (fig. 2-35) in its mounting position in the 2A5A2J1 mounting bracket and secure it with two 2A5A7 casing screws (C, fig. 2-33).

(d) Position resistors 2A5A2R1 and 2A5A2R2 in place (A, fig. 2-33) and secure

them with the screws, the washers, and the spacers removed in (1)(b) above.

(e) Replace front panel assembly 2A5 on the chassis by performing the procedures given in a(2) above.

g. Stator Assembly 2A9 (fig. 2-31 and 2-32).

(1) Removal.

(a) Remove the turret drum assembly part of 2A2, by performing the procedure given in chapter 3.

(b) Tilt the chassis up and remove the three screws (6, fig. 2-32) that secure stator assembly 2A9 to the chassis.

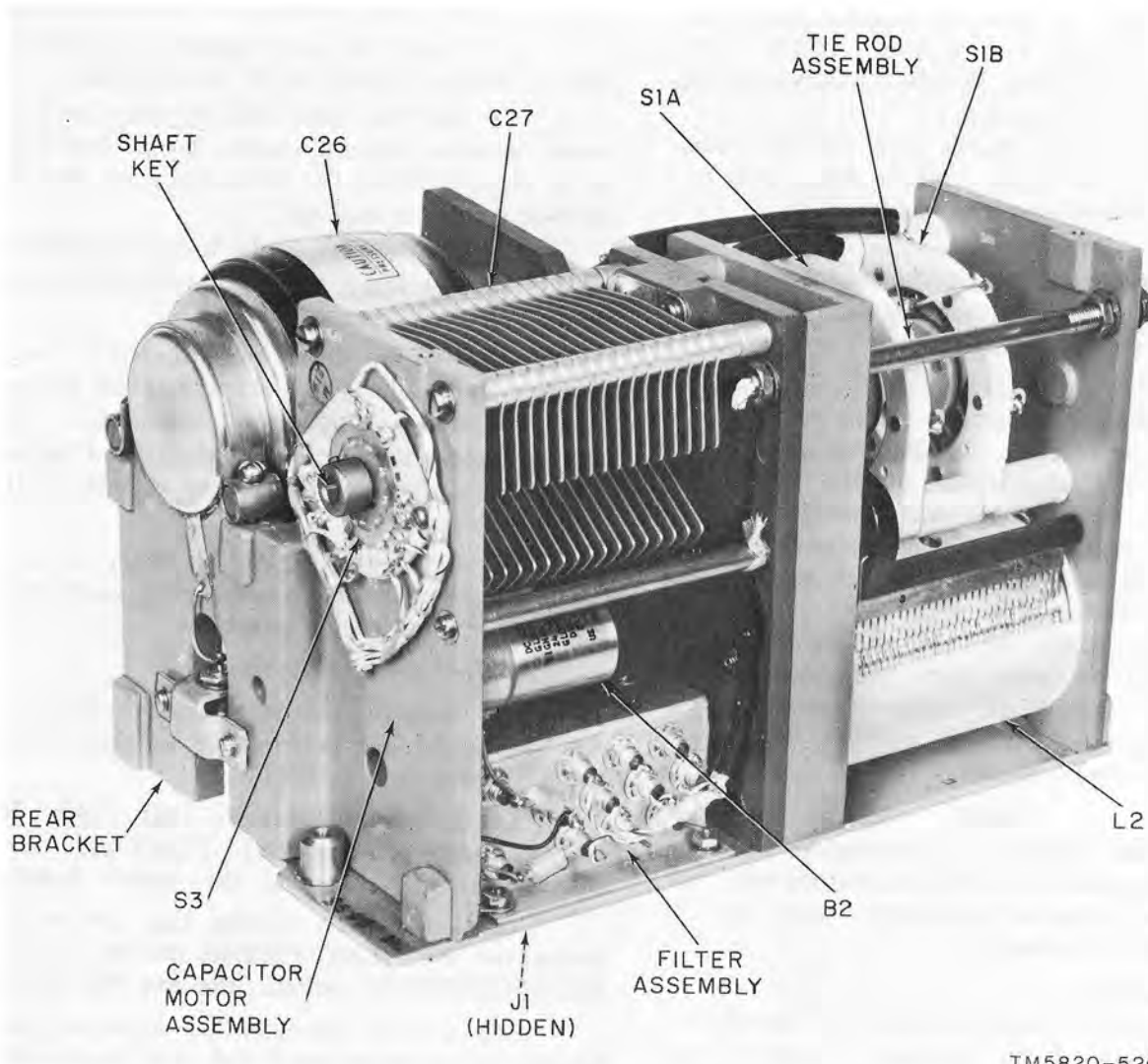

TM5820-520-35-837

Figure 2-37. Antenna coupler assembly 2A3, parts location, rear oblique view.

(c) Remove the two screws from the plate holding the top of stator assembly 2A9.

(d) Slide the assembly toward the right, directly away from the wall of plenum assembly 2A1A1, until connectors 2A9J1B, 2A9J1A disengage from 2A1XA9B and 2A1S1XA9A.

(2) Replacement.

(a) Set the new or repaired stator assembly 2A9 in place on the chassis to engage the connectors ((d) above) on the plenum assembly wall and firmly press into place.

(b) Tilt the chassis up and replace the three original screws to secure the assembly to the chassis.

(c) Replace the two screws to secure the plate that holds the top of stator assembly 2A9.

(d) Replace the turret drum assembly by performing the procedures outlined in para 3-36.

h. Relay Assembly 2A7 (fig. 2-31).

(1) Removal.

(a) Set PRIM. PWR. circuit breaker at OFF and disconnect all interconnecting cables.

(b) Loosen the six front panel Allen screws and slide the chassis out from the case.

(c) Four captive Allen-head screws are located much below the top plate cover of the relay assembly 2A7 can be seen by looking down through the rectangular cutouts at each corner of the top plate. Loosen the four captive screws that secure the relay assembly 2A7 to the chassis and lift out the assembly.

(2) *Replacement.*

(a) Plug the new or repaired relay assembly to engage connectors 2A7J1 and 2A1A1XA7 and tighten the four captive screws ((1) (c) above) to secure it.

(b) Slide the chassis back into the case, tighten the front panel Allen screws, and reconnect all interconnecting cables.

2-20. Removal and Replacement of Parts for Front Panel Assembly 2A5 (fig. 2-33)

CAUTION

1. After replacement of A2Q2 or Q1, both transistors in the AM-3349/GRC-106 should be of the same type, either two MHT-8901's or two STC-2114's. The transistor type is stamped on the shell casing of the transistor.
2. When A2Q2 or Q1 shorts out, it will, in turn, burn out resistor A2R2 or A2R1. These resistors should be checked before A2Q2 or Q1 are replaced.

NOTE

Transistor A2Q2 or Q1 insulators are items separate from the transistors and must be ordered separately when a transistor is ordered.

a. *Disassembly.*

(1) *Dc-to-dc converter assembly 2A5A2.*

(a) Remove the dc-to-dc converter assembly 2A5A2 from the main AM-3349/GRC-106 chassis by performing the procedures given in paragraph 2-19f(1).

(b) To replace transistor A2Q2, proceed as follows:

1. Remove the three screws that secure the bracket for diode A2VR1 and capacitors A2C3 and A2C4 and lay the bracket aside (fig. 2-34).

2. Remove the two screws that secure relay A2K2 and remove the relay.

3. Unsolder the leads to transistor A2Q2. Tag each lead to insure proper replacement.

4. Remove the three screws that secure the heat sink and then remove heat sink.

5. Unscrew and remove transistor A2Q2.

6. Wipe the heat sink surface clean.

7. Apply a light coat of silicon grease

(MIL-G-3278) to the bottom surface of the new transistor and Molycote G to the threads.

8. Insert the new transistor and tighten with a torque wrench to 60 inch-pounds.

9. Set the heat sink in place and replace the three original screws. Insure that there is no short between the transistor case and the dc-to-dc converter casting.

10. Solder the leads to the transistor.

11. Set relay A2K2 in place and replace the two original screws.

12. Set the diode and capacitor bracket in place and replace the three original screws.

(c) When replacing transistor Q1, always replace the beryllium washer and tighten the new transistor with a torque wrench to 100 to 120 inch-pounds.

(d) Replace or repair all other parts of the dc-to-dc converter assembly in accordance with the standard shop practices.

(2) *Gear drive assembly.*

(a) Remove the dc-to-dc converter assembly 2A5A2 by performing the procedures given in paragraph 2-19f(1).

(b) Loosen the screws that secure the crank handles for the ANT. TUNE and ANT. LOAD controls. Remove the crank handles.

(c) Loosen the screws that secure the knobs for the TEST METER switch and the TUNE-OPERATE switch. Remove the knobs.

(d) Remove the nuts that secure switches S2 and S6 to front panel and pull the switches out from the back.

(e) Remove the four screws that secure board A5 to the gear drive assembly and lay the board aside.

NOTE

Depending on the lead dress, the securing hardware for switch 2A5S4 and relay 2A5K1, or the leads to all three meters and the mounting hardware for assembly 2A5A3 may have to be removed in order to perform the procedures given in (f) below.

(f) Remove the three screws that secure the gear drive assembly to the front panel and then remove the gear drive assembly.

(g) Replace or repair all parts of the gear drive assembly in accordance with the standard shop practices.

(3) *Front panel.***NOTE**

Disassemble the front panel only as far as necessary to reach the part to be replaced. Tag each unsoldered lead to insure proper replacement.

(a) Remove the gear drive assembly by performing the procedures given in *a*(2) above.

(b) Replace or repair all other parts of the front panel in accordance with the standard shop practices.

*b. Reassembly.***NOTE**

When replacing parts on the front panel, use the original hardware unless damaged, then use exact replacement. Insure good solder joints when soldering leads.

(1) After the front panel has been repaired, replace the gear drive assembly as follows:

(a) Set the gear drive assembly in place and replace the three original screws.

NOTE

Replace any item that had to be removed to perform the procedure given in *a*(2) (*f*) above.

(b) Set board A5 in place and replace the four original screws.

(c) Set switches S2 and S6 in place and replace the nuts on the front of the front panel to secure the switches.

(d) Replace the knobs for the TEST METER and TUNE-OPERATE switches.

(e) Replace the crank handles on the ANT. TUNE and ANT. LOAD controls.

(2) Replace the front panel assembly on the chassis by performing the procedures given in paragraph 2-19*a*(2).

2-21. Removal and Replacement of Parts for Chassis Assembly 2A1

a. Replacement of 2A1A1V1 and 2A1A1V2 Tubes.

(1) Insure that input power is disconnected then, disconnect the RF drive cable.

(2) Insure that the RT-662/GRC or RT-834/GRC SERVICE SELECTOR switch is at off.

WARNING

Before touching any components inside of the AM-3349/GRC-106, remove

power from the unit, take cover off power amplifier tubes 2A1A1V1 and V2, and short the plates of the tubes to ground with a shorting stick.

(3) Remove the cover from power amplifier tubes 2A1A1V1 and 2A1A1V2 by loosening the four captive screws into the plenum and two screws into the stator assembly.

(4) Short the plates of power amplifier tubes 2A1A1V1 and 2A1A1V2 to ground by using a shorting stick.

(5) Using a screwdriver, release the tube clamp snaps and remove power amplifier tubes 2A1A1V1 and 2A1A1V2 from their sockets by using a tube puller. Place a new 8322 (4CX350F) tube in 2A1A1V2 socket. Close tube clamp snap. Place wad of cloth in empty tube socket to force cooling air over other tube.

(6) Set the AM-3349/GRC-106 PRIM. PWR. switch at ON.

(7) Set the RT-662/GRC or RT-834/GRC SERVICE SELECTOR switch at SSB/NSK.

(8) Set the AM-3349/GRC-106 TEST METER switch at PRIM. VOLT. The TEST METER should indicate in the two dark green wedges portion of the scale. If it does not, adjust the input voltage until it does.

(9) Connect the positive lead of a multimeter to the AM-3349/GRC-106 chassis. Connect the negative lead of the multimeter to J11 (PA IDLE CURRENT) (fig. 2-31) on the bracket located on the top center of the front panel of the AM-3349/GRC-106.

(10) Set the AM-3349/GRC-106 HV-RESET switch to TUNE.

(11) Adjust resistor 2A1A1R5 (indicated on ANTENNA COUPLER cover diagram as V2 BIAS ADJ.) for a multimeter indication of 0.215 VDC.

(12) Allow 10 minutes for the tube current to stabilize. Readjust resistor 2A1A1R5 (fig. 2-31) if necessary to obtain a 0.215 vdc indication on the multimeter.

(13) Set the HV-RESET switch to OPERATE. After approximately one minute set the RT-662/GRC or RT-834/GRC SERVICE SELECTOR switch to OFF.

(14) Short the plate of the power amplifier tube to ground using a shorting stick.

(15) Using a screwdriver, release the tube clamp snap and remove the tube.

(16) Repeat the above steps, except place new tube in the 2A1A1V1 socket. Place a wad

of cloth in the empty 1A1A1V2 socket, and adjust 2A1A1R6 (VI BIAS ADJ) resistor.

(17) Remove the cloth from the empty tube socket and place good tube in the socket.

(18) Replace the cover over the power amplifier tubes.

(19) Set the AM-3349/GRC-106 PRIM. PWR. switch to ON.

(20) Set the RT-662/GRC or RT-834/GRC SERVICE SELECTOR switch to SSB/NSK.

(21) Connect a CG-409G/U cable between RF DRIVE connectors of the RT-662/GRC or RT-834/GRC and the AM-3349/GRC-106.

(22) Tune the RT-662/GRC or RT-834/GRC frequency selector controls to 29.5000 MHz.

(23) Place the AM-3349/GRC-106 HV-RESET switch in the TUNE position.

(24) Adjust the ANT TUNE and ANT LOAD controls to center their respective meters.

(25) Using an insulated tuning tool, adjust the 2A1A1C22 (fig. 2-31) plate trimmer capacitor for a minimum indications on the multimeter.

(26) Place the AM-3349/GRC-106 HV-RESET switch in the OPERATE portion.

(27) Place the RT-662/GRC or RT-834/GRC SERVICE SELECTOR switch in the OFF position. Refer to the procedures of paragraph 2-30 for neutralization capacitor adjustment.

b. Removal and Replacement of Blower 2A1A1B1.

NOTE

On some old models of AM-3349/GRC-106 the 2A1A1B1 motor is not removable and unit must be returned to depot for repair.

(1) Remove turret assembly 2A2 using the procedures found in chapter 3, para 3-36b.

(2) Remove driver assembly 2A8 using the procedures of paragraph 2-19e.

(3) Unsolder the three blower motor leads from A1J10, A1J19, and A1C1. Note position of wires to insure proper replacement.

(4) Remove cable clamps from leads. Retain parts for reassembly.

(5) Remove two clamps from blower assembly and lift out blower.

(6) Insert new blower assembly in chassis and tighten the two clamps removed in step (5).

(7) Feed motor leads through case and along cable to terminal board. Lace leads to cable and reinstall cable clamps.

(8) Solder the three motor leads to the destinations noted in step (3).

(9) Reinstall driver assembly 2A8.

(10) Reinstall turret assembly 2A2.

2-22. Removal and Replacement of Blower Assembly 2A6B1

a. Remove four screws from blower cover.

b. Remove four screws from blower bracket and remove bracket.

c. Remove the three nuts from terminals E1, E2, and E3.

d. Note the position of the leads on the E terminals then remove them.

e. Place leads of new 2A6B1 motor on the E terminals (fig. 4-54); yellow-E1, green-E2, red-E3. Terminals are marked on back.

f. Replace three nuts removed in step *c.*

g. Reinstall bracket to blower using four screws removed in step *b.*

h. Mount blower assembly in case using four screws in step *a.*

2-23. Removal and Replacement of Parts for Relay Assembly 2A7 (fig. 3-47)

a. Remove relay assembly 2A7 using the procedures of paragraph 2-19h.

b. Remove the four screws from the 2A7 cover and lift off cover.

c. Replace relays K2, K3, K5, or K6 as necessary by pulling old relay from socket and plugging new relay in its place.

d. Place cover on assembly and secure with four screws removed in step *b.*

e. Reinstall assembly 2A7 according to paragraph 2-19h.

2-24. Replacement of Driver Amplifier Tube 2A8V1

NOTE

Complete procedure must be followed when changing tube.

a. Remove the tube shield by twisting counterclockwise and pulling straight out. Pull the driver amplifier tube 2A8V1 (8233) straight out of its socket. Rocking the tube may damage socket connections.

b. Plug new 8233 tube into the socket.

- c. Set the AM-3349/GRC-106 PRIM. PWR. switch to ON.
- d. Set the RT-662/GRC or RT-834/GRC SERVICE SELECTOR switch to SSB/NSK.
- e. After one minute set the AM-3349/GRC HV-RESET switch to TUNE.
- f. Set the AM-3349/GRC-106 TEST METER switch to PRIM. VOLT. The TEST METER pointer should indicate in the two green wedges portion of the scale. If it does not, adjust the input voltage.
- g. Set the AM-3349/GRC-106 TEST METER switch to DRIVER CUR and observe that

TEST METER pointer is in the two dark green wedges portion of the scale. If not, adjust resistor 2A8A1R6 (accessible at rear center of chassis) for a pointer indication between the two green portions of the scale.

- h. Set the AM-3349/GRC-106 PRIM. PWR. switch at OFF. Set the RT-662/GRC or RT-834/GRC SERVICE SELECTOR switch at OFF.

NOTE

If resistor 2A8A1R6 requires adjusting, it is located on the back of the AM-3349/GRC-106 chassis.

Section VII. INSPECTION AND SERVICE

2-25. Direct Support Inspection

Inspection at the direct support level is limited to items listed in table 2-11.

Table 2-11. Items Requiring Direct Support Inspection

Unit	Assembly	Number
RT-662/GRC and RT-834/GRC	Panel and chassis.....	1A1
	100 kHz synthesizer....	1A2
	Frequency standard....	1A3
	1 kHz synthesizer.....	1A4
	Transmitter IF and audio	1A5
	Frequency divider.....	1A6
	Receiver IF.....	1A7
	MHz synthesizer.....	1A9
	Receiver audio.....	1A10
	De-to-de converter and regulator	1A11
	AM-3349/GRC- 106	Chassis.....
Antenna coupler.....		2A3
Discriminator.....		2A4
Front panel.....		2A5
Relay assembly.....		2A7

Remove assemblies in accordance with paragraphs 2-17 through 2-19. Module covers are removed by turning the bail handles one-half turn counterclockwise. Inspect the assemblies for the following defects.

- a. *General.* All assemblies and subassemblies should be clean and free of foreign material.
- b. *Connectors.* Connectors are not serviceable if they have bent, broken or corroded contacts.
- c. *Markings.* All nomenclature markings, stampings and decals shall be clean and legible.
- d. *Covers.* The cover is not serviceable if any of the following conditions exist: distortion, holes, or marred finish, corrosion or finish deficiency.
- e. *Castings.* The casting is not serviceable if any of the following conditions exist: broken

or cracked casting, marred or damaged holes, machined surfaces, or threads.

- f. *Gears.* The gear is not serviceable if any of the following conditions exist: broken, chipped or badly worn teeth; cracked or deformed bodies.

- g. *Bearings.* The bearing is not serviceable if any of the following conditions exist: discoloration caused by burning (blue or purple), rusting, tarnishing, etc.; scarred or scuffed surfaces; excessive radial play; or rough or pitted raceways or balls; flat balls, broken parts, as indicated by pronounced, erratic noises. When rotating the bearing either mechanically (use lubricating oil per Specification MIL-L-6085) or manually, a slight uniform noise is to be expected. A loud or nonuniform noise, such as clicks, buzzes, or vibration originating in the bearing is sufficient cause for rejection of the bearing.

- h. *Machined Metal Parts.* The machined or mechanical metal part is not serviceable if any of the following conditions exist: physical damage to surfaces, corners, and edges; roughness of surface; corrosion or rust; presence of foreign matter; or damaged finish.

- i. *Electrical Components.* All electrical parts shall show no indication of broken, cracked or otherwise deteriorated insulation due to ageing, overheating, flashover or other mechanical damage. All connecting wires shall be of the correct length and insulated as required by the applicable part.

- j. *Rubber, Synthetic Rubber, and Neoprene Parts.* The rubber, synthetic rubber or neoprene part is not serviceable if any of the following conditions exist: deformation (tears, creases, folds, elongation); rough surfaces; imbedded foreign matter; or loss of resiliency.

k. Tube Shields. The tube shield is not serviceable if any of the following conditions exist: marred finish; damaged or deformed shield; damaged or missing tube shield springs; corrosion or rust.

l. Ceramic Insulators and Tube Sockets. Ceramic parts are not serviceable if any of the following conditions exist: damage to surfaces and edges, roughness of surface, scratches, signs of insulation breakdown or flashover, badly worn or broken threads, cracked or deformed bodies.

m. Molded, Extruded, and Machined Plastic Parts. The plastic part is not serviceable if any of the following conditions exist: cracks, dents, bulges, or scratches; signs of insulation breakdown or flashover; or badly worn or broken threads in tapped holes.

n. Window, Filters, and Lenses. The window, filter, or lens is not serviceable if any of the following conditions exist: cracked or chipped paired markings. If inspection reveals a defective assembly refer to repair procedures. If assembly is found serviceable, place covers on modules and fasten by pressing on bail handle and turning it one-half turn clockwise until it locks. Reinstall modules and assemblies in accordance with paragraphs 2-17 through 2-19.

2-26. Cleaning

WARNING

The fumes of trichloroethane are toxic. Provide thorough ventilation whenever used. DO NOT use near an open flame. Trichloroethane is not flammable, but exposure of the fumes to an open flame converts the fumes to highly toxic dangerous gases.

This paragraph contains procedures for cleaning the assemblies, subassemblies and detail parts of AN/GRC-106(*). The cleaning may be done before or after inspection as necessary. References to an air jet signify a hand-operated air nozzle supplied with clean, dry, compressed air at a pressure of not more than 25 pounds per square inch.

a. Covered Cables. Clean outer surface of rubber or vinylite covered cables, or conduits of flexible, transparent vinylite, by wiping dust from cable surfaces and terminations with a lintless cloth moistened with trichloroethane. Wipe dry with a clean, dry, lintless cloth.

b. Open Laced Cables. Remove dust and dirt from cables using a soft brush in conjunction

with an air jet. Clean lug terminations and any vinylite sleeves by wiping clean with a lintless cloth moistened with trichloroethane and drying with a clean, dry, lintless cloth.

c. Connectors.

CAUTION

Do not allow trichloroethane to run into sleeves (or conduit) covering wires or cables connected to contact terminals of the insert.

Wipe dust and dirt from bodies, shells, coupling nuts and cable clamps using a lintless cloth moistened with trichloroethane. Wipe dry with a clean, lintless cloth. Remove dust from inserts using a small, soft brush in conjunction with an air jet. Wash dirt and any trace of lubricant from insert, insulation and contacts using a small camels' hair brush to apply trichloroethane. Dry connectors with an air jet.

d. Wired Chassis.

CAUTION

To avoid air blasting of small coils, leads and other delicate components, do not place air nozzle too close to chassis. Exercise care not to disturb the dress of wiring and cables except where absolutely necessary. In the event it is necessary, the dress should be noted. Upon completion of the cleaning operation, wiring and cables should be restored to their original position or dressed to prevent misalignment and malfunctioning of the equipment.

Remove dust and dirt from all surfaces using a soft brush and an air jet. Clean individual components as described in the applicable paragraph in this section. Complete chassis cleaning by wiping all finished surfaces with a lintless cloth, moistened with trichloroethane. Dry and polish chassis surfaces using a dry, clean, lintless cloth. Touch up minor damage to finish. Protect chassis from dust and moisture during storage.

e. Coaxial Connector Contacts. Clean coaxial connector contacts and insulating members by wiping away dust and dirt with a lintless cloth moistened with trichloroethane. Dry with a clean, dry, lintless cloth.

f. Glass or Ceramic Insulators. Clean all terminal-mounting insulators of glass or glazed porcelain, all post-type, glazed-porcelain mountings or standoff insulators, bushing and other

forms of glass or ceramic insulators. Wipe insulator clean using a clean cloth moistened with trichloroethane. Dry and polish insulator with a clean, dry, lintless cloth.

g. Castings. Remove bulk of surface grease with rags. Blow dust from surfaces, holes and recesses with air jet. Place casting in washing bath of trichloroethane and scrub until clean, working trichloroethane over all surfaces and into all holes and recesses with suitable non-metallic brushes. Flat, woodbacked brushes with soft fiber bristles are recommended for surfaces. Round brushes similar to those used for washing bottles and test tubes are recommended for holes and recesses. Raise casting from bath and permit trichloroethane to drain into bath. Place casting in rinsing bath of clean trichloroethane and raise from bath. Position casting to drain dry so that trichloroethane is not trapped in holes or recesses. Where positioning will not permit complete drainage, use an air jet to remove any trapped trichloroethane. When thoroughly dry, touch up minor damage to casting finish. Protect casting from dust and moisture pending inspection.

h. Machined Metal Parts. Clean detached gears, shafts, keys, collars, springs and similar machined metal parts as described in *g*.

CAUTION

After cleaning, avoid touching any machined or unfinished steel surfaces with bare hands. This precaution will help prevent corrosion.

i. Mechanical Metal Parts. Clean mounting plates, mounting clamps, or brackets, blower fans or wheels, handles, attaching hardware and similar parts as described in *g*.

j. Plastic Parts: Molded, Extruded, and Machined. Blow loose dust from surfaces, holes, and crevices and from any attached metal parts using an air jet. Wipe clean with a lintless cloth moistened with trichloroethane. Dry and polish with a clean, dry lintless cloth.

k. Rotary Switches. Clean rotary switches of the wafer type as follows: Remove dust with an air jet by turning switch back and forth several times while blowing. Wash all contacts and insulation with trichloroethane, lightly applied with a small, camels' hair brush. Dry with an air jet. Repeat wash, using clean trichloroethane and rotating switch rotor several times during the wash. Dry gently, but thoroughly with air jet.

l. Electron Tubes.

NOTE

Abrasives or metal tools should not be used to remove corrosion deposits on tube contacts. These deposits are indicative of damage to contact plating and inspection will probably order tube replacement.

Remove dust and dirt from surfaces of glass or metal envelope and side of tube base with a lintless cloth moistened with trichloroethane lightly applied to avoid obliterating type markings or loosening tube cap terminal, if any. Dry and polish these surfaces by gently wiping them with a dry, clean, lintless cloth. Clean bottom of base and all tube contacts with a soft-bristled brush. Protect electron tubes from dust and breakage.

m. Tube Sockets. Remove resin adhering to silver-plated contacts, using orange sticks dressed to wedge ends.

CAUTION

Do not use metal tools to remove foreign matter from silver-plated contacts as damage to contact plating invites corrosion which may ultimately result in equipment failure.

Wash contacts with trichloroethane, lightly applied with a small, soft-bristled brush. Remove foreign matter adhering to socket body or wafer using a lintless cloth moistened with trichloroethane. Dry all parts with air jet.

n. Sensitive and Toggle Switches. Blow dirt from surfaces of switch bodies and attached mechanisms using an air jet. Wipe surfaces with a lintless cloth moistened with trichloroethane and dry with an air jet.

o. Windows, Filters, and Lenses. Clean plastic or glass disks, windows, filters, and lenses by gently wiping their surfaces with a clean, soft, lintless cloth that has been dampened with trichloroethane. When clean, polish carefully with lens tissue using a circular motion. If object is to be stored for any period of time, be sure surfaces are well protected.

2-27. Lubrication

a. General. This section contains information and instructions required to lubricate Radio Set AN/GRC-106(*). The symbol Q on illustrations indicate intervals and designates 3 months. A 3-month interval consists of ninety 8-hour days. If the equipment is operated more

than 8 hours per day, increase the frequency of lubrication accordingly. The contacts of all switches should be lubricated with any standard switch lubricant at 6-month intervals. This helps to insure optimum performance by keeping the contacts clean and free from corrosion. Use lubricants MIL-M-7866A(ASG), FSN-NISL-P/N 15091, or FSN-NISL-P/N 15093 for all other points.

b. Receiver-Transmitter, Radio RT-662/GRC and RT-834/GRC (fig. 2-27).

(1) *General.* The following paragraphs contain required instructions for lubricating Receiver-Transmitter, Radio RT-662/GRC and RT-834/GRC. Appropriate disassembly and reassembly procedures are included.

(2) *Disassembly.* Loosen the six front panel Allen screws and slide the chassis out. Place the chassis on a bench on the right side. Remove the two screws that secure the small motor gear drive assembly cover (next to large gear) and remove cover (fig. 2-27). The motor gear drive assembly cover has two press-fitted guide pins to insure proper positioning of the cover.

(3) *Gear drive assembly lubrication.* Locate all lubrication points (fig. 2-38). Connect Power Supply PP-4763/GRC to the units front panel POWER connector and set for an output of 27 volts dc. Set the SERVICE SELECTOR switch at SSB/NSK. Change the MHz and kHz controls to any new frequency. As the gears rotate, clean lubrication points with a brush dipped in trichloroethane. Change the MHz and kHz controls to any new frequency. As gears rotate, apply a light film of lubricant MIL-M-7866A (ASG) to lubrication points specified in figure 2-38. Use a clean brush for this application. Repeat this procedure until all points are cleaned and lubricated. Set the SERVICE SELECTOR switch at OFF. Disconnect the PP-4763/GRC.

(4) *Reassembly.*

(a) Replace the motor gear drive assembly cover over the guide pins and secure with the two original screws.

(b) Tip the chassis upright, slide it back into the case, and tighten the front panel Allen screws.

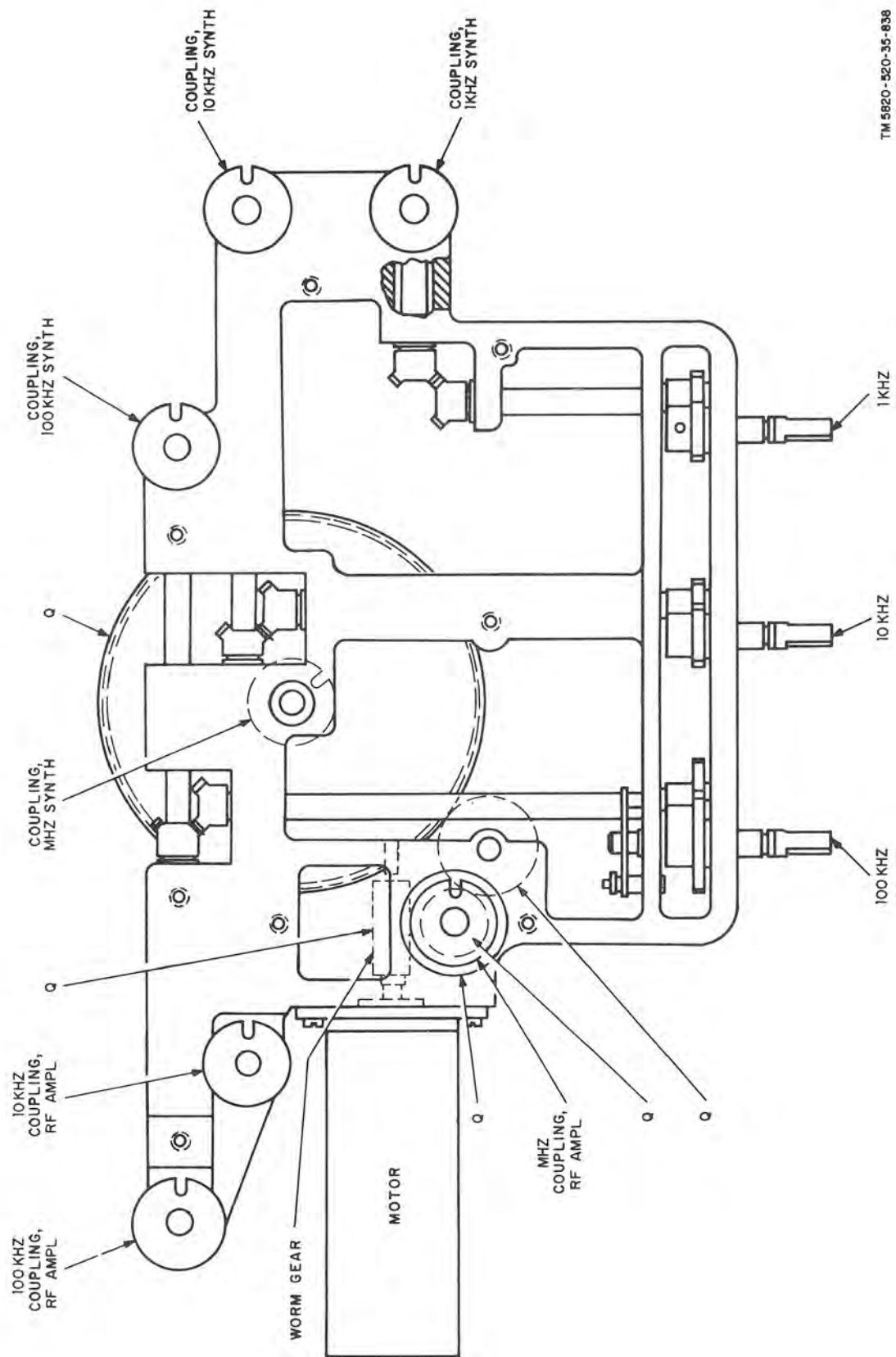

TM 5820-520-35-838

Figure 2-38. Receiver-Transmitter, Radio RT-662/GRC and RT-834/GRC lubrication points.

Section VIII. DIRECT SUPPORT ADJUSTMENTS

**2-28. Test Equipment and Special Tools
Required for Adjustments**

The following is a list of test equipment required to perform the procedures contained in this section.

a. Test Equipment.

Item	Technical manual
Signal Generator AN/URM-127 (2 required)	TM 11-6625-683-15
Digital Readout Electronic Counter AN/USM-207	TM 11-6625-700-10
Generator, Signal AN/GRM-50	TM 11-6625-573-15
Spectrum Analyzer TS-723(*)/U	TM 11-5097
Voltmeter, Electronic AN/URM-145 with adapter 91-8A	TM 11-6625-524-14
Multimeter ME-26(*)/U	TM 11-6625-200-12

b. Additional Equipment.

- (1) Dummy Load DA-75/U.
- (2) Telegraph Key KY-116/U.
- (3) Power Supply PP-4763(*)/GRC.
- (4) 50 ohm, 1 watt, 10 percent resistor.
- (5) Adapter, RF-9997.
- (6) Test cables:
 - (a) Cable Assembly, Special Purpose, Electrical (w-23) (FSN 5995-832-6861).
 - (b) Cable Assembly, R. F. (w-25) (FSN 5995-935-0350).

NOTE

Cables (a) and (b) above are part of SM-442A/GRC.

2-29. Power Amplifiers 2A1A1V1 and 2A1A1V2, Neutralization Capacitor Adjustment

a. General. To insure optimum performance, neutralization capacitor 2A1A1C4 (fig. 2-31) should be adjusted for minimum distortion each time power amplifier tube 2A1A1V1 or 2A1A1V2 is replaced.

b. Test Equipment Required. Connect Cable Assembly, Special Purpose, Electrical CX-10099/U (6 ft) between the PA CONTROL connector on Receiver-Transmitter, Radio RT-662/GRC or RT-834/GRC front panel and the CONTROL connector on Amplifier, Radio Frequency AM-3349/GRC-106 front panel. Connect Cable Assembly, Radio Frequency CG-

409G/U (5 ft) between the RF DRIVE connectors on the two units. Connect Power Supply PP-4763(*)/GRC to the RT-662/GRC or and to the AM-3349/GRC front panel PRIM. PWR. connector. Set the PP-4763/GRC for an output of 27 volts dc. Connect voltmeter, electronic AN/URM-145 as required during the procedure. Turn on the test equipment and allow a 15-minute warmup period.

c. Procedure. To adjust neutralization capacitor 2A1A1C4 (fig. 2-31), proceed as follows:

WARNING

Voltages up to 3,000 volts dc and 10,000 volts rf exist in the AM-3349/GRC-106. Be extremely careful when working with the equipment operating outside the case. Disconnect the power source and use a shorting stick to ground capacitors before touching any components. After turning off set, wait 15 seconds before shorting capacitors 2A5A2C6 and C5 (fig. 2-33) in order to prevent damage to capacitor 2A5A2C6.

(1) Set the AM-3349/GRC-106 PRIM. PWR. circuit breaker at ON and set the RT-662/GRC or RT-834/GRC SERVICE SELECTOR switch at CW.

(2) Set the RT-662/GRC or RT-834/GRC MHz and kHz controls at 29500.

(3) After 60 seconds, set the AM-3349/GRC-106 HV RESET switch to TUNE.

(4) Adjust ANT. TUNE and ANT. LOAD controls to center their respective meter indications.

(5) Set HV RESET switch to OPERATE.

(6) Set PRIM. PWR. and SERVICE SELECTOR switches to OFF.

(7) Loosen the six front panel Allen screws and slide the AM-3349/GRC-106 chassis out.

(8) Unsolder the blue-white lead between power amplifier 2A1A1V1 and 2A1A1V2 screens and resistor 2A1A1R3 at the resistor end (fig. 4-51). Resolder this end to ground terminal next to 2A1A1R3.

(9) Loosen the four captive screws and remove relay assembly 2A7 (fig. 2-31). Unsolder the lead from terminal 2A1A1E3. In the same area plug a pin jack into the GND test

point and connect the unsoldered lead to it. Replace relay assembly 2A7.

(10) Connect the 91-8A adapter to the probe of the AN/URM-145 and connect this to the 50 OHM LINE connector on AM-3349/GRC-106.

(11) Connect the multiconductor test cable (w-23) (FSN 5995-832-6861) between case connector 2A6XA1 (fig. 4-54) and chassis connector 2A1J1.

(12) Set the AM-3349/GRC-106 PRIM. PWR. circuit breaker at ON and set the RT-662/GRC or RT-834/GRC SERVICE SELECTOR switch at CW.

(13) After 60 seconds, set the AM-3349/GRC-106 HV RESET switch at TUNE.

(14) Adjust the AN/URM-145 for maximum meter indication.

(15) Use an insulated adjustment tool to adjust neutralization capacitor 2A1A1C4 (fig. 2-31) for a null indication on the AN/URM-145.

(16) Set the AM-3349/GRC-106 PRIM. PWR. circuit breaker and the RT-662/GRC or RT-834/GRC SERVICE SELECTOR switch at OFF.

(17) Turn off all power. Use a shorting stick to short the plates of power amplifier tubes

2A1A1V1 and 2A1A1V2 to ground. Disconnect all test equipment.

(18) Unsolder the grounded end of the screen lead and resolder it to tap 1 of 2A1A1R3 ((8) above).

(19) Refer to the procedures of paragraph 3-45c(4) through (17).

(20) Slide the chassis back into the case and tighten the front panel Allen screws.

2-30. Power Amplifiers 2A1A1V1 and 2A1A1V2 and Driver Amplifier 2A8V1, Plate Trimmer Capacitors Adjustment

a. General. To insure optimum performance, plate trimmer capacitors 2A8C6 and 2A1A1C22 should be adjusted each time power amplifier tube 2A1A1V1 or 2A1A1V2 is replaced. The adjustment of neutralization capacitor 2A1A1C4 (para 2-29) must be accomplished before the performance of this procedure.

b. Test Equipment Required. Connect all equipment as shown in figure 2-39. Turn on the test equipment and allow a 10-minute warmup period. Set Radio Set AN/GRC-106(*) switches and controls as listed in table 2-12 below.

Table 2-12. Switches and Controls Settings

Unit	Control	Setting
RT-662/GRC or RT-834/GRC	SERVICE SELECTOR switch	OVEN ON (allow 10 minutes warm-up)
RT-662/GRC or RT-834/GRC	MANUAL RF GAIN control	Fully clockwise
RT-662/GRC or RT-834/GRC	AUDIO GAIN control	Approximately midrange
RT-662/GRC or RT-834/GRC	SQUELCH switch	OFF
RT-662/GRC or RT-834/GRC	FREQ. VERNIER control	OFF
RT-662/GRC or RT-834/GRC	BFO control	Approximately midrange
RT-662/GRC or RT-834/GRC	Vox switch	PUSH TO TALK
AM-3349/GRC-106	PRIM. PWR switch	OFF
AM-3349/GRC-106	HV RESET switch	TUNE
RT-662/GRC or RT-834/GRC	SERVICE SELECTOR switch	STAND BY (allow 60 seconds warmup)

c. Procedure. To adjust plate peaking capacitors 2A8C6 and 2A1A1C22 (fig. 2-31), proceed as follows:

WARNING

Voltages up to 3,000 volts dc and 10,000 volts rf exist in the AM-3349/GRC-106. Be extremely careful when working with the equipment operating outside the case. Disconnect the power source and use a shorting stick to ground the capacitors before touching

any components. Wait 15 seconds after turning off power before shorting 2A5A2C5 and 2A5A2C6 so as to prevent damage to 2A5A2C6.

(1) Loosen the six front panel Allen screws and slide the AM-3349/GRC-106 chassis out.

(2) Connect the multiconductor test cable cited in paragraph 2-28 between case connector 2A6XA1 and chassis connector 2A1J1.

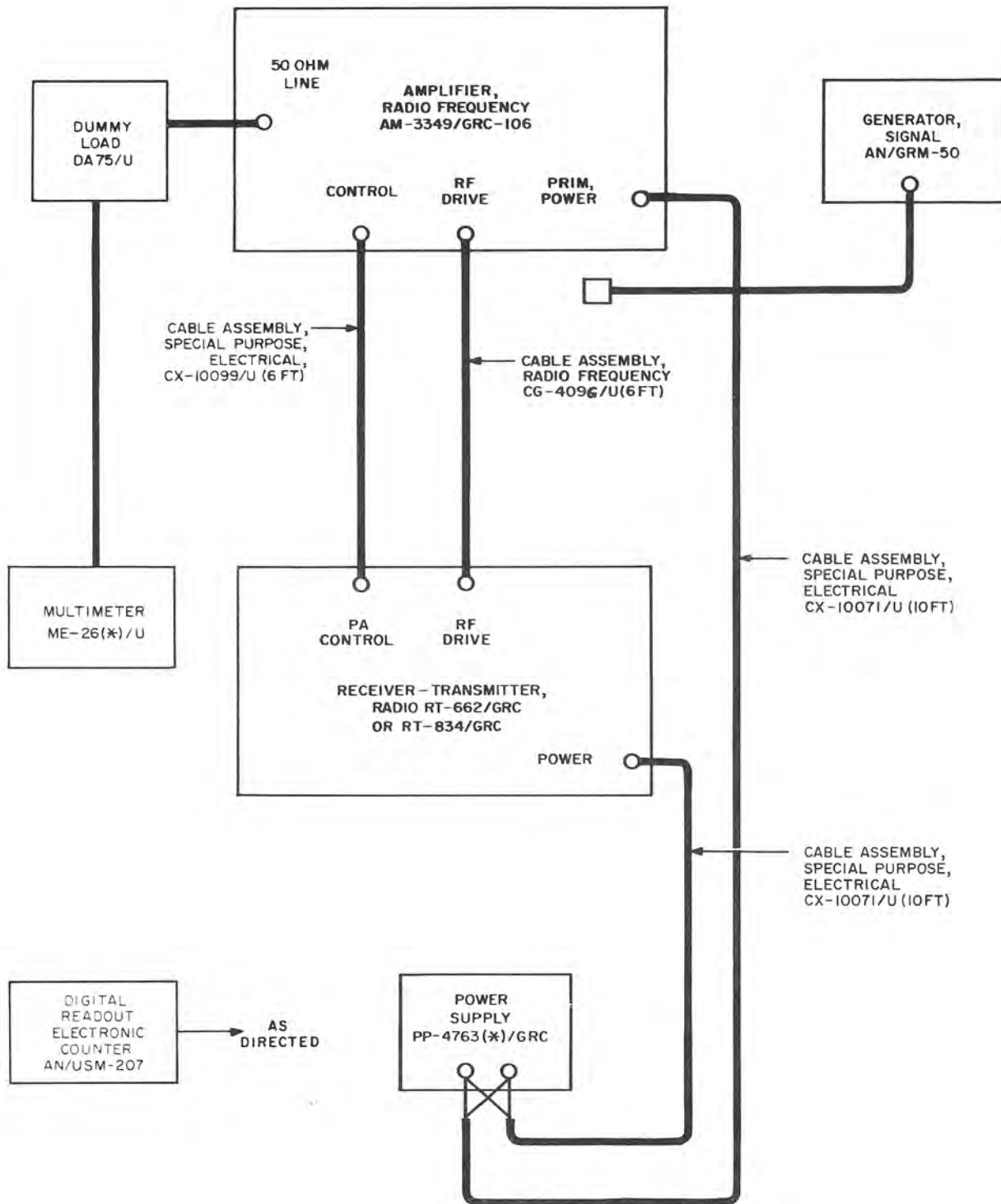

TM5820-520-35-840

Figure 2-39. AM-3349/GRC-106 plate trimmer setup.

(3) Set the AM-3349/GRC-106 PRIM. PWR. circuit breaker at ON. Set the PP-4763/GRC output for 27 volts dc.

(4) Set Receiver-Transmitter, Radio RT-662/GRC or RT-834/GRC SERVICE SELECTOR switch at CW and set the MHz and kHz controls at 29500. Allow the tuning cycle to be completed before proceeding.

(5) Adjust the AM-3349/GRC-106 ANT. TUNE and ANT. LOAD controls until the counters indicate the numbers shown in the antenna tuning and loading chart for 29.9 MHz for a 50 ohm load.

(6) Set the HV RESET switch at TUNE and simultaneously adjust the ANT. TUNE and ANT. LOAD controls until the meters indicate in the green portion of the scales.

(7) Set the HV RESET switch at OPERATE and set the RT-662/GRC or RT-834/GRC SERVICE SELECTOR switch at OFF.

(8) Disconnect the cable from the AM-3349/GRC-106 RF DRIVE connector.

(9) Use a shorting stick to short the plate of power amplifier 2A1A1V2 to ground. Remove relay assembly 2A7. Connect a pin jack to the GND test point. Unsolder the wire from terminal 2A1A1E3 and connect it to the banana jack. Replace relay assembly 2A7.

(10) Connect frequency meter AN/USM-207 to the output of Signal Generator AN/URM-50.

(11) Adjust the AN/GRM-50 for an am output of 29.5 MHz as indicated on the AN/USM-207.

(12) Set the AN/GRM-50 output level at zero and connect to the AM-3349/GRC-106 front panel RF DRIVE connector.

(13) Set the AM-3349/GRC-106 TEST METER switch at PA. CUR.

(14) Set the RT-662/GRC or RT-834/GRC SERVICE SELECTOR switch at SSB/NSK and allow a 60-second warmup period.

(15) Increase the AN/GRM-50 output level until voltmeter, ME-26(*)/U indicates 50 volts. Monitor the AM-3349/GRC-106 TEST METER to insure that the meter pointer does not go out of the gray portion of the scale.

(16) Set the TEST METER switch at GRID DRIVE.

(17) Adjust PLATE TRIM C6 capacitor 2A8C6 (fig. 4-16) until a peak indication is obtained on the TEST METER.

(18) Set the TEST METER switch at PA. CUR.

(19) Adjust the AN/GRM-50 output for 29.00 MHz at 50 volts as indicated on the ME-26(*)/U.

(20) Note the indication of the AM-3349/GRC-106 TEST METER.

(21) Adjust the AN/GRM-50 output for 29.99 MHz 50 volts as indicated on the ME-26(*)/U.

(22) Note the indication of the AM-3349/GRC-106 TEST METER.

(23) Repeat the procedure given in (19) through (22) above while adjusting capacitor 2A1A1C22 (fig. 2-31) until the indications noted in (20) and (22) above are equal.

(24) Turn off all power. Use a shorting stick to short the plates of power amplifier tubes 2A1A1V1 and 2A1A1V2 to ground. Disconnect the test cable.

(25) Remove relay assembly 2A7. Disconnect the lead from the pin jack and resolder it to terminal 2A1A1E3. Replace relay assembly 2A7.

(26) Slide the chassis back into the case and tighten the front panel Allen screws.

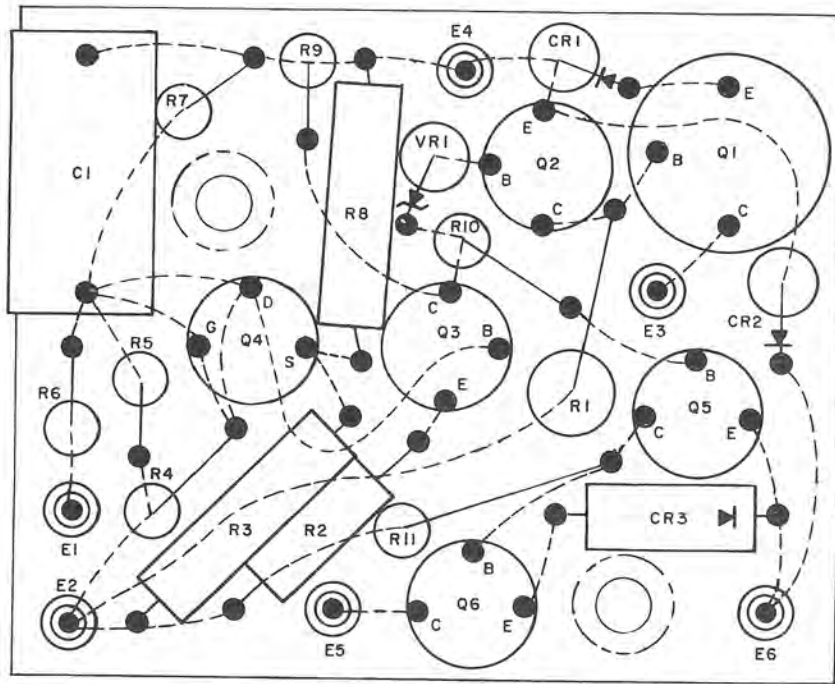

- NOTES:
1. CIRCUIT VIEWED FROM SIDE ON WHICH PARTS ARE MOUNTED.
 2. — PARTS AND PIGTAILS ON FRONT OF BOARD.
 3. --- WIRING ON BACK OF BOARD.

TM5820-520-35-C3-3

Figure 2-40. Amplifier, Radio Frequency AM-3349/GRC-106, blower protection circuit board 2A1A2, parts location diagram.

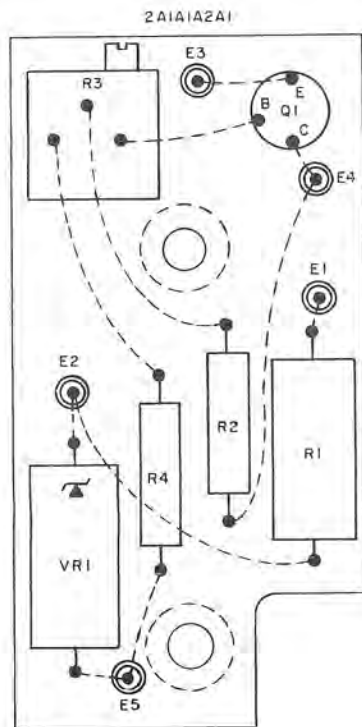
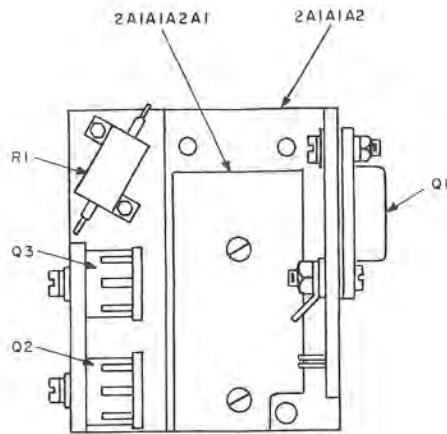

- NOTES:
1. CIRCUIT VIEWED FROM SIDE ON WHICH PARTS ARE MOUNTED.
 2. — PARTS AND PIGTAILS ON FRONT OF BOARD.
 3. - - - WIRING ON BACK OF BOARD.

TM5820-520-35-C3-4

Figure 2-41. Amplifier, Radio Frequency AM-3349/GRC-106, filament regulator assembly 2A1A2A1 parts location diagram.

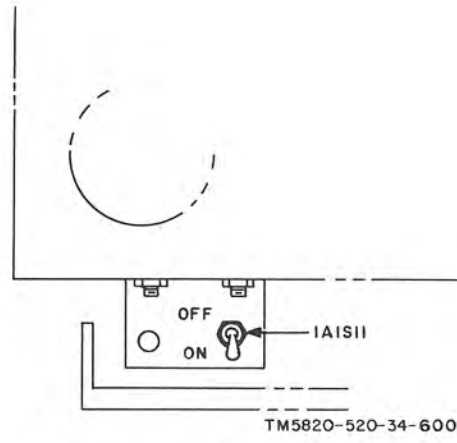

Figure 2-42. AGC/auto level control.

CHAPTER 3

GENERAL SUPPORT MAINTENANCE

Section I. GENERAL

WARNING

When servicing Radio Set AN/GRC-106(*) be extremely careful when working on or around the circuits of dc-to-dc converter and regulator module 1A11, dc-to-ac inverter (part of front panel assembly 2A6), antenna coupler 2A3, and front panel assembly 2A5. Voltages as high as 3,000 volts dc and 10,000 volts rf exist in these assemblies.

CAUTION

This equipment is transistorized. When measuring voltages, use tape or sleeving (spaghetti) to insulate the entire test prod, except the extreme tip. A momentary short circuit can ruin a transistor.

3-1. Scope of General Support Maintenance

a. The general support maintenance procedures in this chapter include: troubleshooting, module adjustments, lubrication, repair and replacement, circuit testing and performance testing. Chapter 4 contains the module test procedures.

b. Figures 4-56(1), 4-56(2), 4-57(1), and 4-57(2) are provided to aid the repairman in circuit tracing from the modules on the RT-

662/GRC or RT-834/GRC, to the modules on the AM-3349/GRC-106, or from the AM-3349/GRC-106 to the RT-662/GRC or RT-834/GRC.

3-2. Test Equipment Required for General Support Maintenance

Table 3-1 lists the test equipment and associated technical manuals required for general support maintenance.

Table 3-1. Test Equipment Required for General Support Maintenance

<i>Test Equipment</i>	<i>Federal stock number</i>	<i>Technical manual</i>
Simulator, Radio Frequency SM-442A/GRC	6625-999-7485	TM 11-6625-847-12
Power Supply PP-4763(*)/GRC	5820-937-769	TM 11-5820-765-12
Dummy Load, Electrical DA-75/U	5985-280-3480	
Dummy Load, Electrical 50-ohm, 2W	5985-087-4954	
Test Set, Electron Tube TV-2/U	6625-669-0263	TM 11-6625-316-12
Test Set, Transistor TS-1836/U	6625-893-2628	TM 11-6625-539-15
Test Set, Transmission AN/USM-306	6625-453-666	
Spectrum Analyzer TS-723(*)/U		TM 11-5097
Oscilloscope AN/USM-281A	6625-053-3112	TM 11-6625-1703-15
Digital Readout, Electronic Counter AN/USM-207	6625-911-6368	TM 11-6625-700-10
Dummy Load Group, Electrical OA-4539/GRC-106	5985-089-4379	
Multimeter ME-26(*)/U	6625-360-2493	TM 11-6625-200-15
Multimeter TS-352B/U	6625-884-1758	TM 11-6625-203-12
Multimeter AN/URM-105	6625-242-5023	TM 11-6625-366-15
Voltmeter, Electronic AN/URM-145	6625-973-3986	TM 11-6625-524-14
Voltmeter, Electronic ME-30(*)/U	6625-973-0742	TM 11-6625-320-12
Meter, Audio Level TS-585/U	6625-244-0501	
Generator, Signal AN/URM-127	6625-783-5965	TM 11-6625-683-15

Table 3-1. Test Equipment Required for General Support Maintenance—Continued

Test Equipment	Federal stock number	Technical manual
Generator, Signal AN/GRM-50	6625-868-8353	TM 11-6625-573-15
Attenuator, Hewlett-Packard HP-355D	5985-957-1680	
Probe T-connector HP-11042	6625-713-4356	
Attenuation, Variable CN-764/U	5985-020-2990	
Handset H-33(*)/PT	5965-163-9947	
Loudspeaker LS-166/U	5965-243-6420	
Telegraph Key KY-116/U	5805-503-3395	
Headset H-227/U	5995-226-2915	
Microphone M-29B/U	5965-892-0722	
Blower, External		
Thermometer	6625-444-6000	
Watch	6645-719-8670	
Tool Kit, Electronic Equipment TK-100/G	5180-605-0079	SC5180-91-CL-S21
Tool Kit, Electronic Equipment TK-105/G	5180-610-8177	SC5180-91-CL-R07
Wrench, Torque	5120-230-6380	
Key Socket Head Screw	5120-827-2967	
Extension Socket Head Wrench (used with Tool Code 28)	5120-243-1689	
Crowfoot attachment (used with Tool Code 28)	5180-181-6764	
Handle, Socket Wrench (used with Tool Code 28)	5120-240-5396	
Socket (used with Tool Code 28)	5120-235-5807	
Universal joint (used with Tool Code 28)	5120-224-9215	
Thermal Noise Generator SG-419/U	6625-853-3866	
Wave Analyzer HP-302A, TS1830/U	6625-958-4473	

3-3. Prior Troubleshooting and Repairing Performances

Prior to troubleshooting and repairing a Radio Set AN/GRC-106(*), determine the need for the following, and perform if necessary.

a. Cleaning. Clean each chassis assembly and subassembly as described in paragraph 2-26.

b. Inspection. Inspect all parts as described in paragraph 2-25.

c. Lubrication. Lubricate all moving metal parts, (nylon parts should not be lubricated) as described in paragraph 2-27.

d. Vacuum Tubes. Replace vacuum tubes 22A1A1V1 and 2A1A1V2 in accordance with paragraph 2-21a, and replace 2A8V1 in accordance with paragraph 2-24.

e. Blower Motors. All blower motors should be checked for proper operation. Motor 2A1A-1B1 in the plenum assembly has an operating life of 2500 hours and should be replaced at regular intervals to prevent overheating of the plenum assembly. On late models of AM-3349/GRC-106 the 2A1A1B1 motor is changed using the procedures of paragraph 2-21a. On early models the motor is press fit and cannot be removed and replaced so a new plenum assembly is required.

f. Antenna Coupler Assembly 2A3. Inspect all electrical contacts and coils 2A3L1 (fig. 2-36) and 2A3L2 (fig. 2-37) for burned spots and corrosion. Repair as necessary.

Section II. GENERAL SUPPORT TROUBLESHOOTING

3-4. General

Voltage measurements for the E-terminals and transistor terminals are given in paragraphs 3-5 through 3-22. For each module or subassembly, the voltage measurements represent the conditions that would exist if the module or subassembly was properly connected to the main chassis, receiving its proper input and output voltages, with the RT-834/GRC or RT-662/

GRC and the AM-3349/GRC-106 properly connected and operating in the receive mode. All dc voltage measurements in the tables in this section were made with Multimeter ME-26(*)/U. All ac voltage measurements unless otherwise indicated, were made with Voltmeter, Electronic AN/URM-145. Where measurements were made under special conditions, the conditions are listed either in the table, or in the instructions immediately preceding the table. Where special test equipment is called out,

such as an oscilloscope or a selective voltmeter, refer to the list of test equipment in table 3-1 for proper nomenclature. Terminal and parts locations are included in the tables when needed.

3-5. Front End Protection Circuit 1A1A1A10

a. *Transistor Dc Voltage Measurements.* All readings in table 3-2 should be within ± 10 percent of the indicated value. Refer to figures 3-1 through 3-3 for parts identification.

Table 3-2. Front End Protective Circuit 1A1A1A10, Transistor Dc Voltage Measurements

Transistor stage	Dc voltage to ground		
	B	E	C
A1Q1	0.2	Ground	10
A2Q1	10	14	27
A2Q2	0.7	Ground	0.5

b. *E-Terminal Voltage Measurements.* The voltage measurements in table 3-3 were made with the instrument indicated in parentheses. Terminal locations are shown in figures 3-2 and 3-3.

Table 3-3. Front End Protection Circuit A1A1A10, E-Terminal Voltage Measurements

Terminal	Voltage measurements
A1E1	+20 vdc—receive mode Ground—transmit mode
A1E2	6 mv rms (AN/URM-145)
A1E3	6 mv rms (AN/URM-145)
A1E4	Ground

Table 3-3. Front End Protection Circuit 1A1A1A10, E-Terminal Voltage Measurements—Continued

Terminal	Voltage measurements
A1E5	20 mv rms (AN/URM-145)
A1E6	+10 vdc
A1E7	20 mv rms (AN/URM-145)
A2E1	+0.5 vdc
A2E2	+10 vdc
A2E3	Same as A1E1
A2E4	Ground
A2E5	Not used
A2E6	+27 vdc

3-6. Internal ALC Assembly 1A1A2A5

a. *Transistor Dc Voltage Measurements.* The dc voltage measurements for transistor Q1 should be within plus or minus 10 percent of the indicated value. The measurements are: base 3.1 to 4.1 volts dc; emitter -2.5 to 3.5 volts dc; and collector +19.5 volts dc. Refer to figure 3-4 and 3-5 for parts location.

b. *E-Terminal Voltage Measurements.* Refer to table 3-4.

3-7. 100 Hz Module 1A1A2A8

NOTE

The 100 Hz module is applicable for RT-834/GRC only.

a. *Transistor Dc Voltage Measurements.* All readings in table 3-5 should be within ± 10 percent of the indicated value. Refer to figures 3-6 through 3-8 for terminal and parts location.

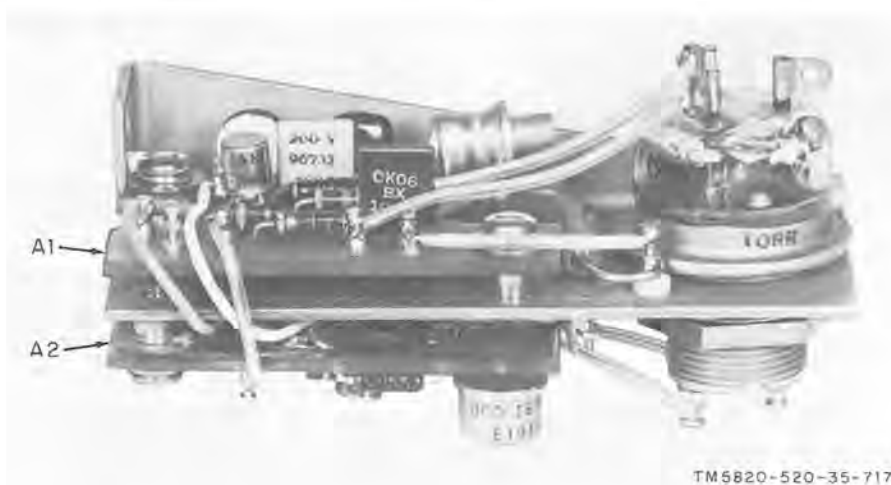

TM5820-520-35-717

Figure 3-1. Front end protection circuit 1A1A1A10, parts location.

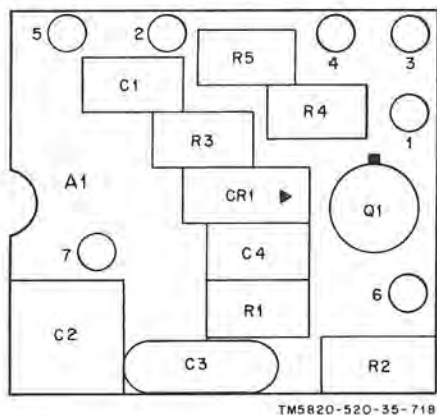

TM5820-520-35-718

Figure 3-2. Terminal board 1A1A1A10A1, parts location diagram.

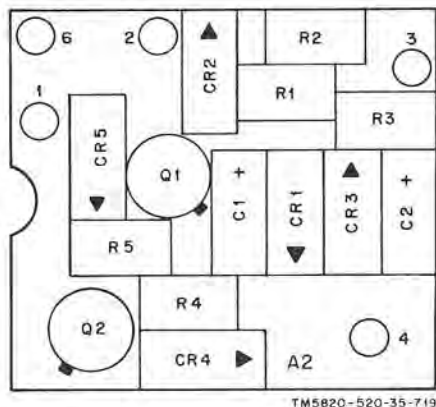

TM5820-520-35-719

Figure 3-3. Terminal board 1A1A1A10A2, parts location diagram.



TM 5820 - 520 - 35 - 720

Figure 3-4. Internal ALC assembly 1A1A2A5, parts location.

c. Code Switch Voltage Measurements. All voltage measurements in table 3-7 were taken with TS-352 B/U and should be either zero volts or 5 volts dc ± 10 percent.

Table 3-4. Internal ALC Assembly 1A1A2A5, E-Terminal Voltage Measurements

Terminal	Voltage measurement
E1	19.5 ± 0.5 vdc.
E2	RF input at a level of 2.5 v rms.
E3	Ground.
E4	Same as E2.
E5	Ground.
E6	A1c output at a level of 2.5 to 3.5 vdc.
E7	Ground.

Table 3-5. 100 Hz Module 1A1A2A8, Transistor Dc Voltage Measurements

Transistor stage	Dc voltage to ground		
	B	E	C
A1Q1	14.0	14.3	14.1
A1Q2		GND	See A1E2
A2Q2	3.5	3.0	13
A2Q3	14	15	9
A2Q4	14	15	9
A2Q5	-0.2	GND	1.8
A2Q6	-1.3	GND	2.5
A2Q7	10.6	10.0	19.3
A2Q8	5.6	5.0	19.5

Table 3-6. 100 Hz Module 1A1A2A8, E-Terminal Voltage Measurement

Terminal	Voltage Measurement
A1E1	15 ± 0.5 VDC (TS-352B/U)
*A1E2	4.5v peak-to-peak square wave
A1E3	2.8 vdc (TS-352B/U)
A1E4	Ground
A1E5	100 Hz squarwave with an amplitude of 5v peak-to-peak AN/USM-281A.
A1E6	5 ± 0.5 vdc (TS-352B/U)
A1E7	See table 3-25
A1E8	See table 3-25
A1E9	See table 3-25
A1E10	See table 3-25
A2E1	Triangular waveform 2v peak-to-peak (AN/USM-281A)
A2E2	Ground
A2E3	105mv rms (AN/URM-145) 7.1 MHz sine wave (AN/USM-281A)
A2E4	19.5 ± 0.5 vdc (TS-352B/U)
A2E5	Same as A1E1.
A2E6	Same as A1E3.
A2E7	Same as A1E5.
A2E8	Same as A1E6.
A2E9	Ground.
A2E20	3.5 vdc (TS-352B/U)

*100 Hz switch at 0.

b. E-Terminal Voltage Measurements. All voltage measurements in table 3-6 were taken with the test equipment listed in parentheses directly after the value. All measurements should be within ± 20 percent of the indicated value.

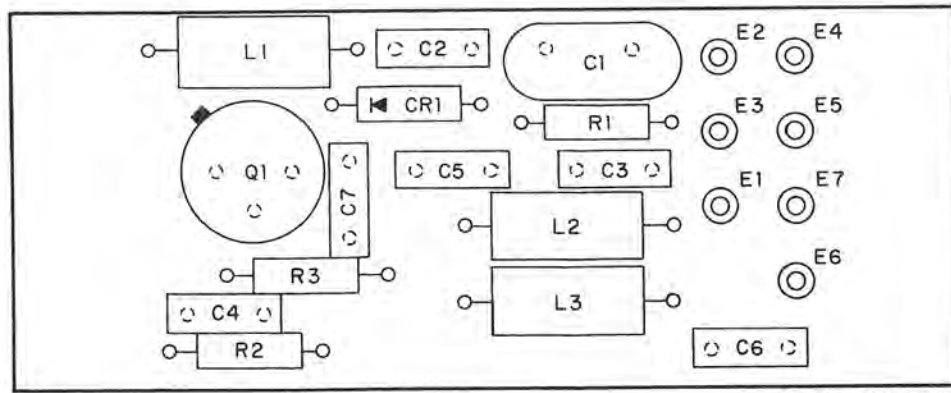

TM5820-520-35-721

Figure 3-5. Terminal board 1A1A2A5A1, parts location diagram.

Table 3-7. 100 Hz Module 1A1A2A8, Code Switch Voltage Measurements

100 Hz code sw digit	Binary code			
	A1E10	A1E8	A1E7	A1E9
0	0	0	0	0
1	0	0	0	1
2	0	0	1	0
3	0	0	1	1
4	0	1	0	0
5	0	1	0	1
6	0	1	1	0
7	0	1	1	1
8	1	0	0	0
9	1	0	0	1
0 =				
OVDC				
1 = 5vdc				
±10%				

3-8. Voltage Regulator 1A1A2A9

NOTE

Voltage Regulator 1A1A2A9 is applicable for RT-834/GRC only.

a. *Transistor Dc Voltage Measurements.* All readings in table 3-8 should be within ±10 percent of the indicated value. Refer to figure 3-9 for terminal and parts location.

Table 3-8. Voltage Regulator 1A1A2A9, Transistor Dc Voltage Measurements

Transistor stage	Dc-voltage to ground		
	B	E	C
Q1	5	6	15
Q2	2.5	1.3	5

b. *E-Terminal Voltage Measurements.* The voltage measurements in table 3-9 were taken with a ME-26(*)/U.

Table 3-9. Voltage Regulator 1A1A2A9, E-Terminal Voltage Measurements

Terminal	Voltage measurement
A9E1	+5 vdc
A9E2	Ground
A9E3	6.3 vac

3-9. 100-kHz Synthesizer Module 1A2

a. *Transistor Dc Voltage Measurements.* All readings in table 3-10 should be within +5 percent of the indicated value. Refer to figure 3-10 for parts location.

b. *E-Terminal Voltage Measurements.* The voltage measurements in table 3-11 were made with the instrument indicated in parentheses. Refer to figures 3-11 through 3-13 for terminal location.

Table 3-10. 100-kHz Synthesizer Module 1A2, Transistor Dc Voltage Measurements

Transistor stage	Dc voltage to ground		
	B	E	C
A1Q1 (high)	7.5	7.6	0
A1Q2 (low)	7.8	8.0	0
A1Q3 (high)	7.8	8.0	0
A1Q4 (low)	7.8	8.1	0
A1Q5	7.5	8.0	0
A2Q1	3.9	4.3	0
A2Q2*	0.55	0	10.3
A2Q3	7.5	7.8	0
A2Q4	9.1	9.2	0
A3Q1	7.5	7.8	0
A3Q2**	13.2	13.6	0
A4Q1**	1.1	1.55	0

* Biasing is controlled by agc voltages. Values shown are typical.

** Not accessible in module. The A4 assembly must be removed from module by unsoldering three leads, loosening four screws on bottom of module, and sliding it out. Connect the A4 assembly back to the module with jumper leads to the three unsoldered leads.

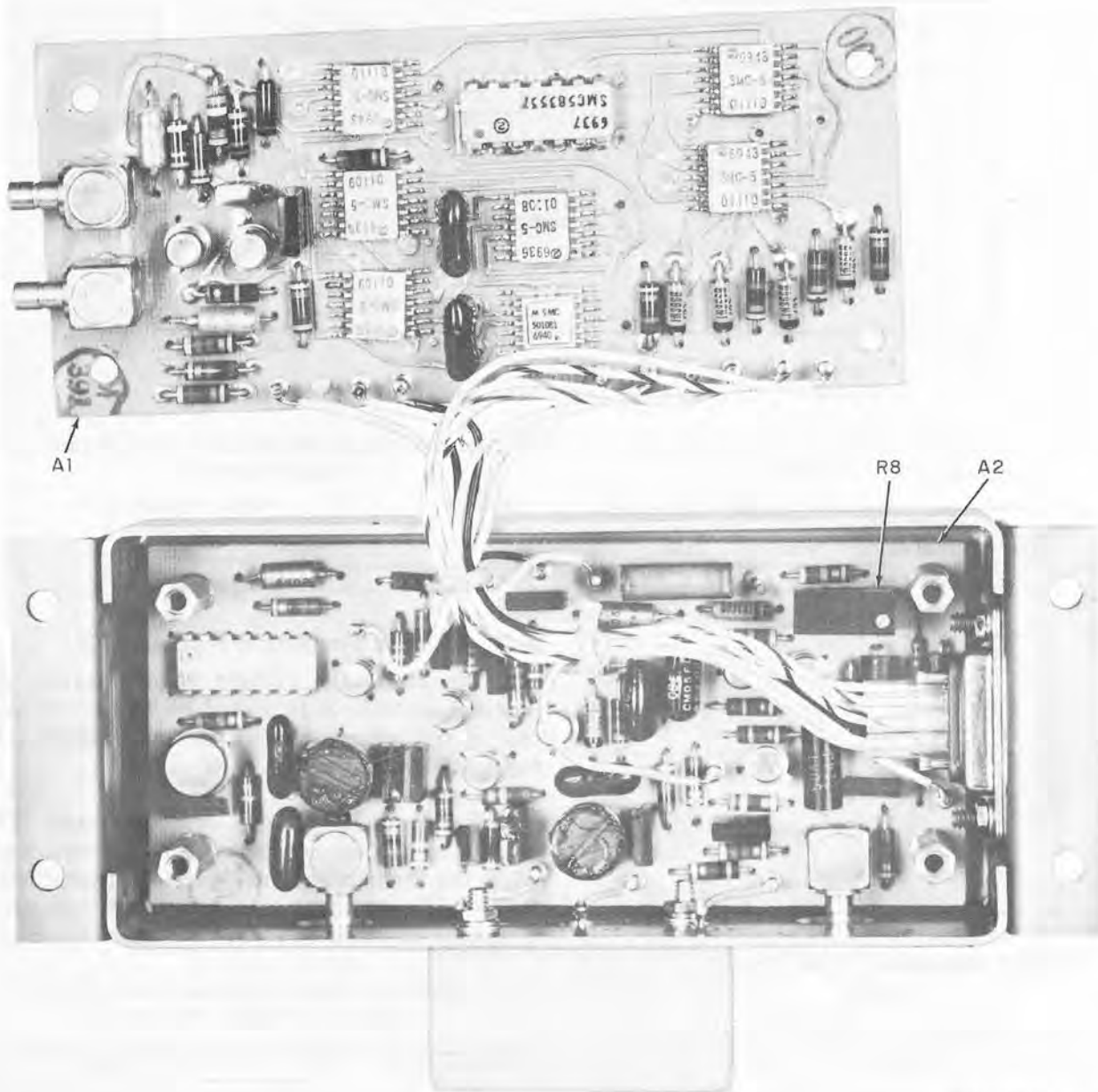

TM5820-520-35-722

Figure 3-6. 100 Hz module 1A1A2A8, parts location.

Table 3-11. 100-kHz Synthesizer Module 1A2, E-Terminal Voltage Measurements

Terminal	Voltage measurement
A1E1	4.553 to 5.453 MHz at a level of 0.58 ±0.12 mv rms 27.847 MHz at a level of approximately 3.0 mv rms (controlled by agc voltage) when the hi-band output is required (AN/USM-306).
A1E2	19.5 ±0.5 vdc with a lo-band output form the module and ground with a hi-band output from the module (ME-26(*)/U).

Table 3-11. 100-kHz Synthesizer Module 1A2, E-Terminal Voltage Measurements—Continued

Terminal	Voltage measurement
A1E3	4.553 to 5.453 MHz at a level of 20 ±3 mv rms (AN/URM-145).
A1E4	Ground.
A1E5	10 ±1 vdc (ME-26(*)/U).
A1E6	Same as A1E2.
A1E7	Ground.
A1E8	4.553 to 5.453 MHz at a level of 0.55 ±0.11 mv rms 17.847 MHz at a level of approximately 3.0 mv rms (controlled by agc voltage) when the lo-

Table 3-11. 100-kHz Synthesizer Module 1A2, E-Terminal Voltage Measurements—Continued

Terminal	Voltage measurement
	band output is required (AN/USM-36).
A1E9	19.5 ± 0.5 vdc (ME-26(*)/U).
A1E10	22.4 to 23.3 MHz (AN/USM-281A) at a level of 130 ± 5 mv rms (AN/URM-145) when a lo-band output is required from the module, and 32.4 to 33.3 MHz (AN/USM-281A) at a level of 150 ± 5 mv rms (AN/URM-145) when a hi-band output is required from the module.
A1E11	4.553 to 5.453 MHz at a level of 0.30 ± 0.06 mv rms and 27.847 MHz at a level of approximately 0.06 mv rms (controlled by agc voltage) when the hi-band output is required from the module (AN/USM-306).
A1E12	32.4 to 33.3 MHz at a level of approximately 4.3 mv rms (controlled by agc voltage) when the hi-band output is required (AN/URM-145).
A1E13	32.4 to 33.3 MHz at a level of approximately 40 mv rms (Controlled by agc voltage) when the hi-band output is required (AN/URM-145).
A1E14	Ground.
A1E15	32.4 to 33.3 MHz at a level of approximately 4.0 mv rms (controlled by agc voltage) when a hi-band output is required from the module (AN/URM-145).
A1E16	4.553 to 5.453 MHz at a level of 0.32 to ± 0.06 mv rms 17.847 MHz at a level of approximately 0.2 mv rms (controlled by agc voltage) when the lo-band output is required from the module (AN/USM-306).
A1E17	22.4 to 23.3 MHz at a level of approximately 18 mv rms (controlled by agc voltage) when the lo-band output from the module is required (AN/URM-145).
A1E18	22.4 to 23.3 MHz at a level of approximately 16 mv rms (controlled by agc voltage) when the lo-band output from the module is required (AN/URM-145).
A1E19	Ground.
A1E20	22.4 to 23.3 MHz at a level of approximately 4.2 mv rms (controlled by agc voltage) when the lo-band output is required from the module (AN/URM-145).
A2E1	Same as A1E10.
A2E2	Agc voltage at a level of approximately 10 vdc (function of agc loop stage gains) (ME-26(*)/U).
A2E3	19.5 ± 0.5 vdc (ME-26(*)/U).
A2E4	Same as A1E3.

Table 3-11. 100-kHz Synthesizer Module 1A2, E-Terminal Voltage Measurements—Continued

Terminal	Voltage measurement
A2E5	Ground.
A2E6	4.553 to 5.453 MHz at a level of 310 ± 30 mv rms (AN/URM-145).
A2E7	19.5 ± 0.5 vdc (ME-26(*)/U).
A2E8	10.747 MHz at a level of not less than 12 mv rms (AN/URM-145).
A2E9	Ground.
A2E10	15.3 to 16.2 mv rms spectrum input at a level of 20 ± 10 mv rms (AN/USM-306) (a, fig. 4-28).
A2E11	19.5 ± 0.5 vdc (ME-26(*)/U).
A2E12	Ground.
A2E13	Ground.
A2E14	22.4 to 23.3 MHz (AN/USM-207) at a level of 100 ± 5 mv rms (AN/URM-145) when the lo-band output is required from the module and 32.4 to 33.3 MHz (AN/USM-281A) at a level of 140 ± 5 mv rms (AN/URM-145) when the hi-band output from the module is required.
A3E15	4.553 to 5.453 MHz and 100 kHz spectrum at a level of 70 ± 20 mv rms (AN/URM-145) (b, fig. 4-28).
A3E1	Same as A1E5.
A3E2	Same as A1E1.
A3E3	7.1 MHz at a level of 35 ± 5 mv rms (AN/URM-145).
A3E4	Ground.
A3E5	Ground.
A3E6	10 MHz at a level of 05 ± 15 mv rms (AN/URM-145).
A3E7	19.5 ± 0.5 vdc (ME-26(*)/U).
A3E8	Same as A2E8.
A3E9	Same as A2E2.
A3E10	Ground.
A3E11	Same as A1E8.
A3E12	Same as A1E2.
A3E13	Same as A1E8.
A3E14	Same as A2E8.
A4E1	Same as A2E6.
A4E2	Same as A2E7.
A4E3	Ground.

3-10. Frequency Standard Module 1A3

a. *Transistor Dc Voltage Measurements.* All the readings in table 3-12 should be within ± 5 percent of the indicated value. Refer to figures 3-14 and 3-19 for parts location.

b. *E-Terminal Voltage Measurements.* All voltage measurements in table 3-13 were taken with the instrument listed in the parentheses directly after the value. Refer to figures 3-19 and 3-20 for terminal location.

Table 3-12. Frequency Standard Module 1A3, Transistor Dc Voltage Measurements

Transistor stage	Dc voltage to ground		
	B	E	C
A2Q1-----	19.0	18.5	0
A2Q2-----	11.7	10.7	0
A2Q3-----	14.2	12.4	0
A2Q1-----	15.5	15.8	0
A3Q2-----	17.5	17.8	0

Table 3-13. Frequency Standard Module 1A3, E-Terminal Voltage Measurement

Terminal	Voltage measurements
A2E1	Ground.
A2E2	1.5 ± 0.5 vdc (ME-26(*)/U).
A2E3	19.5 ± 0.5 vdc (ME-26(*)/U).
A2E4	5 MHz sine wave at an amplitude of 650 ± 150 mv rms (AN/USM-306).
A2E5	500 kHz sine wave at an amplitude of 220 ± 30 mv rms (AN/USM-306).

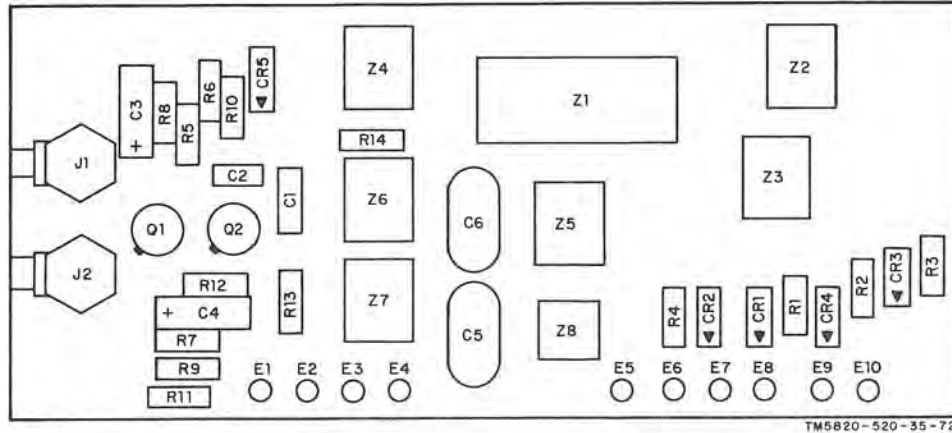

TM5820-520-35-723

Figure 3-7. Terminal board 1A1A2A8A1, parts location diagram.

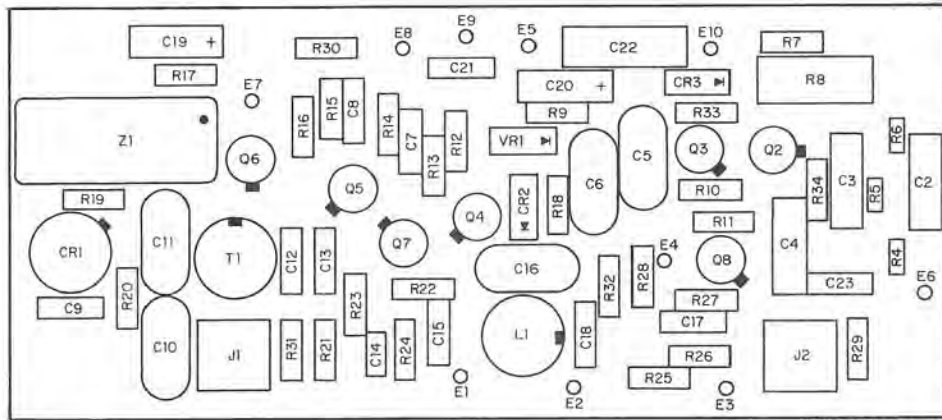

TM5820-520-35-724

Figure 3-8. Terminal board 1A1A2A8A2, parts location diagram.



TM5820-520-35-725

Figure 3-9. Voltage regulator 1A1A2A9, parts location.

Table 3-13. Frequency Standard Module 1A3, E-Terminal Voltage Measurement—Continued

Terminal	Voltage measurements
A2E6	Ground.
A2E7	1 MHz sine wave at an amplitude of 520 ± 80 mv rms (AN/USM-306).
A2E8	Ground.
A2E9	1 MHz signal at a level of 110 ± 20 mv rms, 4 MHz signal at a level of 1.0 ± 0.25 volt rms, and a 5 MHz signal at a level of 475 ± 50 mv rms (AN/USM-306).
A2E10	1 MHz signal at a level of 1.6 ± 0.25 volt rms, 4 MHz signal at a level of 30 ± 7 mv rms, and a 5 MHz signal at a level of 20 ± 5 mv rms (AN/USM-306).
A2E11	Same as A2E10.
A3E1	10 MHz sine wave at an amplitude of 50 ± 15 mv rms (AN/USM-306).
A3E2	Ground.

Table 3-13. Frequency Standard Module 1A3, E-Terminal Voltage Measurement—Continued

Terminal	Voltage measurements
A3E3	5 MHz sine wave at an amplitude of 650 ± 150 mv rms (switch A2S1 in internal position) (AN/USM-306).
A3E4	Ground.
A3E5	19.5 ± 0.5 vdc (ME-26(*)/U).
A3E6	Same as A3E5.
A3E7	Ground.
A3E8	5 MHz sine wave at an amplitude of 120 ± 30 mv rms (AN/USM-306).
A3E9	Ground.

3-11. Frequency Standard Module Oven Assembly 1A3A1

a. Transistor Dc Voltage Measurements. All measurements in table 3-14 should be within

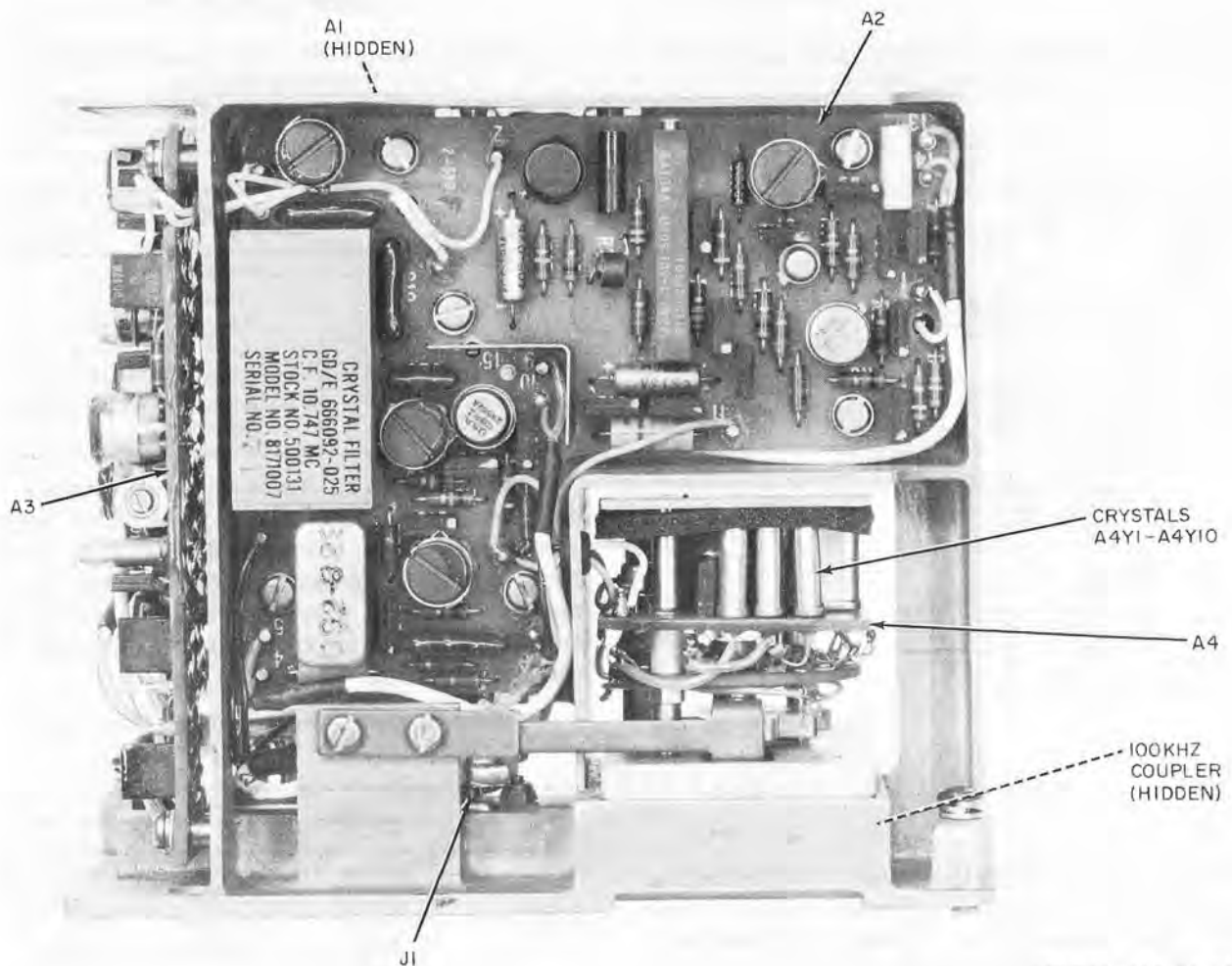

TM5820-520-35-726

Figure 3-10. 100 kHz synthesizer module 1A2, parts location.

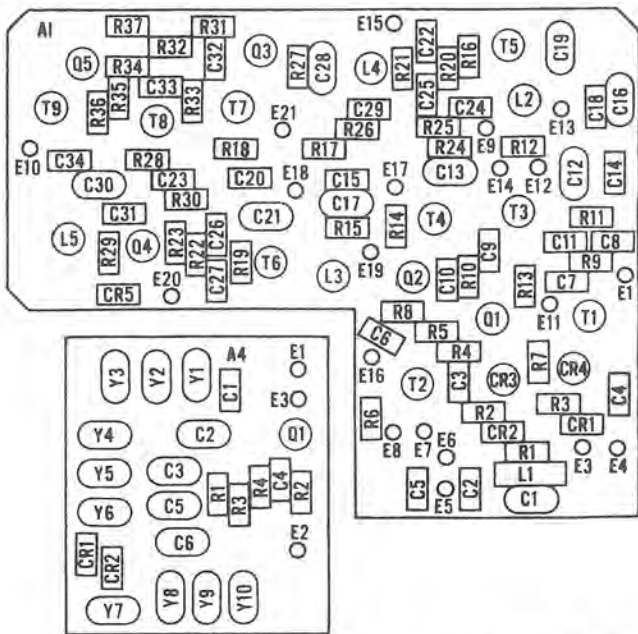

TM5820-520-35-727

Figure 3-11. Printed circuit boards 1A2A1 and 1A2A4, parts location diagram.

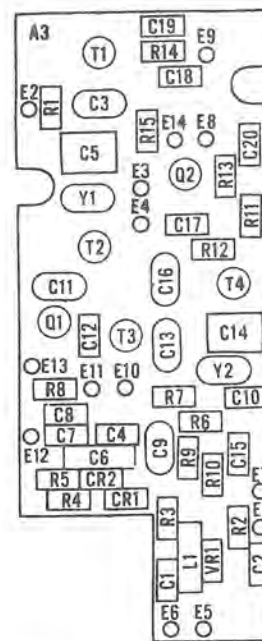

TM5820-520-35-729

Figure 3-13. Printed circuit board 1A2A3, parts location diagram.

Table 3-14. Oven Assembly 1A3A1, Transistor Dc Voltage Measurements

Transistor stage	Dc voltage to ground		
	B	E	C
A1Q1	Not measurable.		
A1A1Q1	7.4	6.8	14.5
A1A1Q2	7.5	6.8	14.0
A1A2Q1	7.2	7.0	15.0
A1A2Q2	15.0	15.0	18 ± 1.2
A1A2Q3	7.8	7.6	7

b. Transistor Ac Voltage Measurements. All measurements in table 3-15 were taken with an oscilloscope on a properly heated oven at ambient room temperature. The indications are nominal and will vary according to the ambient temperature. Refer to figures 3-19 and 3-20 for parts location.

Table 3-15. Oven Assembly 1A3A1, Transistor Ac Voltage Measurements

Transistor stage	Dc Voltage to ground		
	B	E	C
A2Q1	Not measurable.	Not measurable.	200 mv (1.7 kHz).
A2Q2	Same as A2Q1 collector.	Not measurable.	1.7 v (17 kHz).
A2Q3	1.1 v (17 kHz).	Not measurable.	dc.

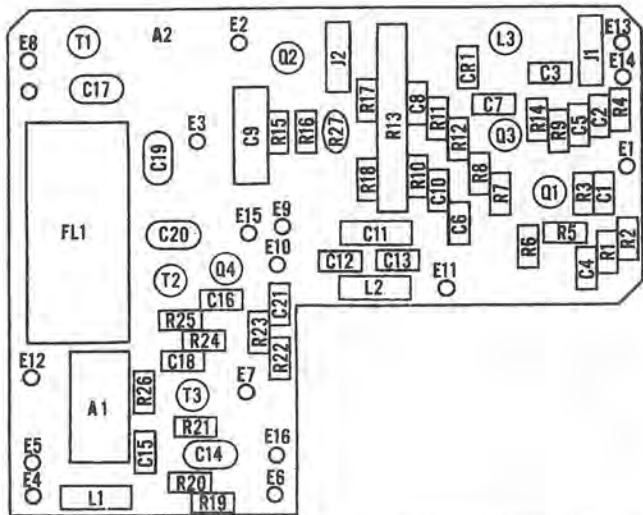

TM5820-520-35-728

Figure 3-12. Printed circuit board 1A2A2, parts location diagram.

5 percent of the indicated value. The measurements are for a properly adjusted oven at ambient room temperature (current of approximately 85 ma from the 27-volt dc power supply). Refer to figures 3-15 through 3-18 for parts location.

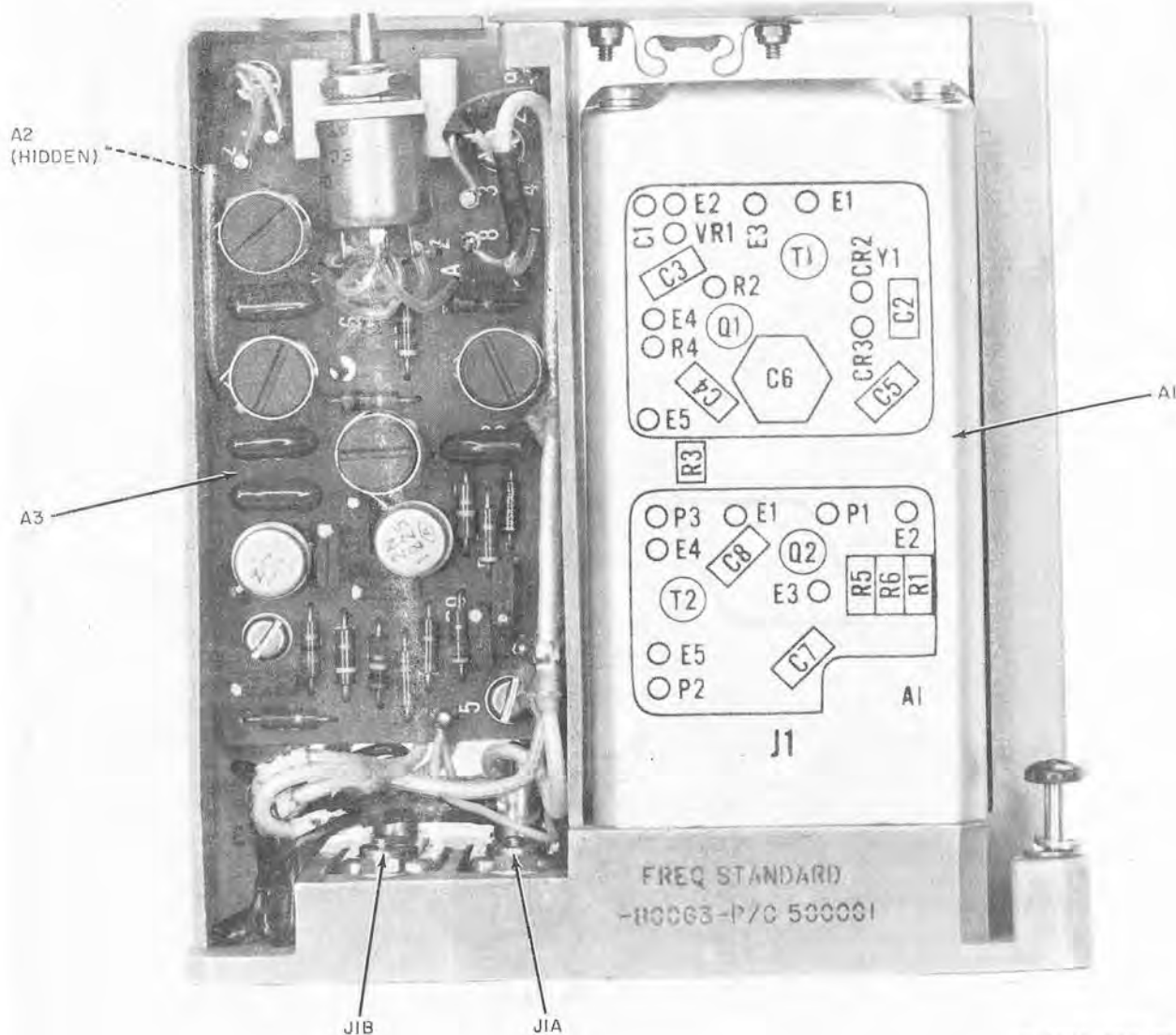

TM5820-520-35-730

Figure 3-14. Frequency standard module 1A3, parts location.

3-12. E-Terminal Voltage Measurements

The measurements for printed circuit board A2 were taken with the oven at 85°C., printed circuit board A1 removed, and with a current of approximately 85 ma from the 27 vdc power supply. Refer to figures 3-17 and 3-18 for terminal location.

Table 3-16. Oven Assembly 1A3A1, E-Terminal Voltage Measurements

Terminal	Voltage measurements
A1P1	1.95 ± 0.5 vdc.
A1P2	5 MHz output signal at a level of 160 ± 40 mv rms.
A1P3	Ground.

Table 3-16. Oven Assembly 1A3A1, E-Terminal Voltage Measurements—Continued

Terminal	Voltage measurements
A2E1	Zero. (Would be same as A1P1 with A1 installed.)
A2E2	Ground.
A2E3	19.5 ± 0.5 vdc.
A2E4	27 ± 3 vdc.
A2E5	Same as A2E3.
A2P2	Same as A2E1.
A2P3	Ground.
A2P4	7.0 ± 1.0 vdc.
A2P5	Same as A2E4.
A2P6	Same as A2E4.
A2P7	Same as A2E4.
A2P8	Variable. Depends on oven temperature.

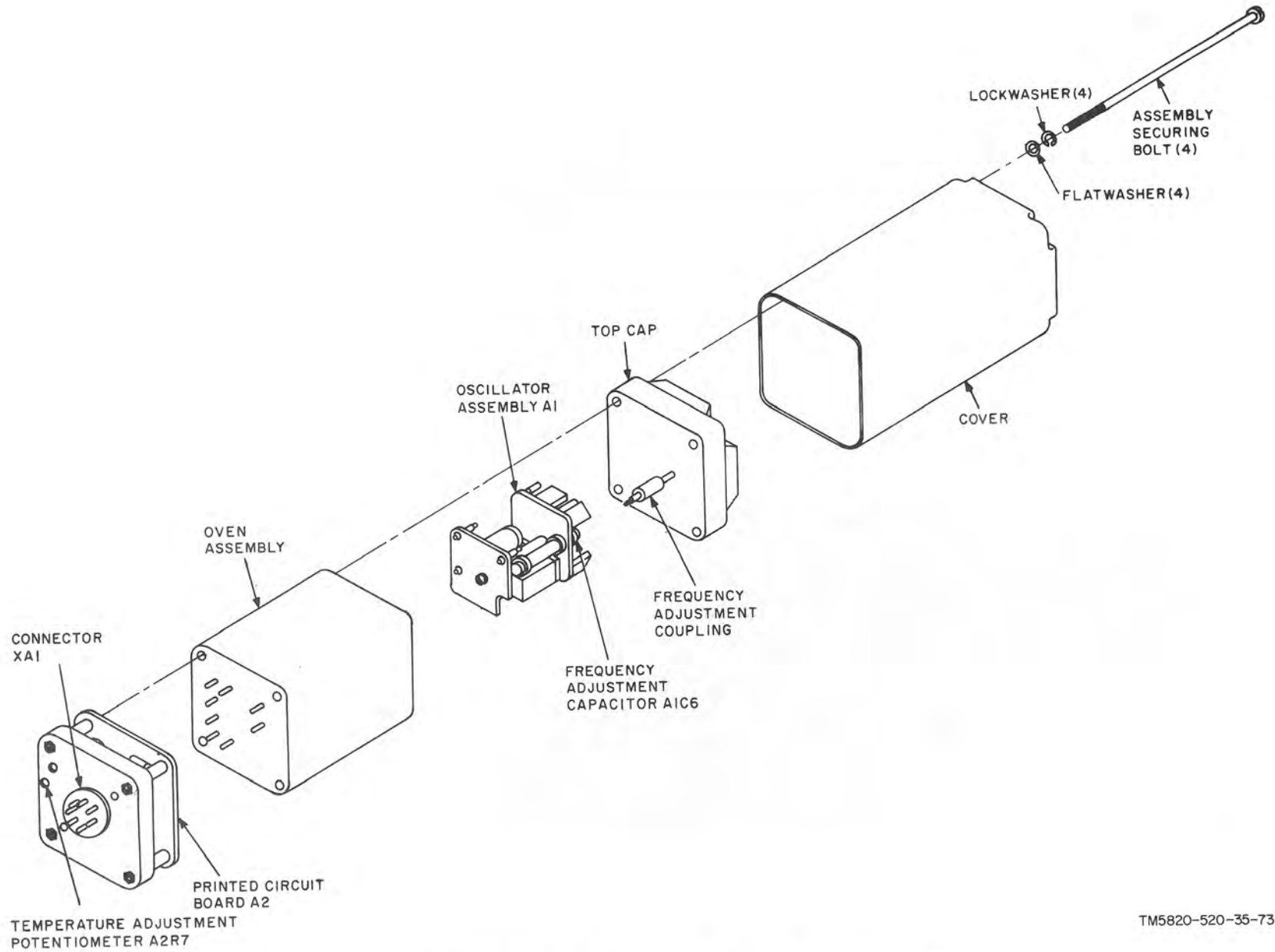
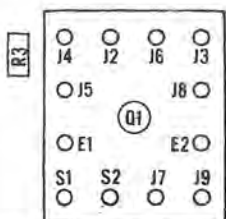
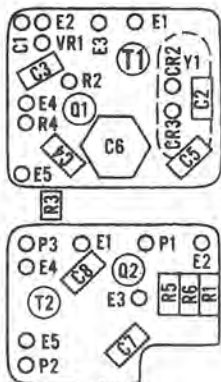

Figure 3-15. Oven assembly 1A3A1, exploded view, parts location diagram.



TM5820-520-35-732

Figure 3-16. Oven assembly 1A3A1, terminal location diagram.



TM5820-520-35-733

Figure 3-17. Printed circuit boards 1A3A1A1-1 and 1A3A1A1-2, parts location diagram.

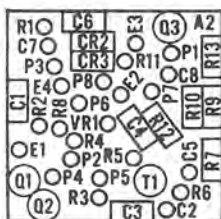

TM5820-520-35-734

Figure 3-18. Printed circuit board 1A3A1A2, parts location diagram.

3-13. 10 and 1 kHz Synthesizer Module 1A4

a. *Transistor Dc Voltage Measurements.* All the readings in table 3-17 should be within ± 5 percent of the indicated value. See figures 3-21, 3-22(1), 3-22(2), 3-23(1), and 3-23(2) for parts location.

b. *E-Terminal Voltage Measurements.* All voltage measurements in table 3-18 were taken with the test equipment listed in parentheses directly after the value. See figures 3-22(1), 3-22(2), 3-23(1), and 3-23(2) for terminal location.

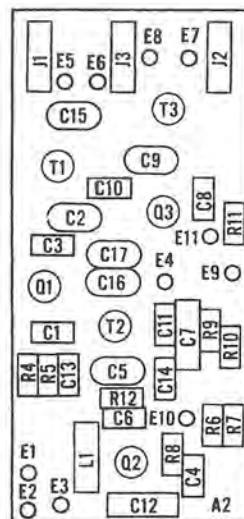

TM5820-520-35-735

Figure 3-19. Printed circuit board 1A3A2, parts location diagram.

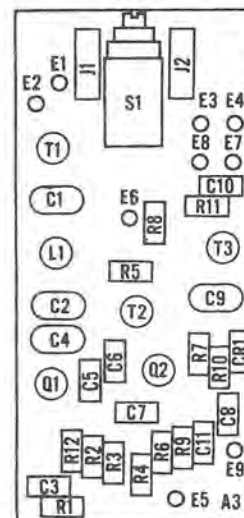

TM5820-520-35-736

Figure 3-20. Printed circuit board 1A3A3, parts location diagram.

Table 3-17. 10 and 1 kHz Synthesizer Module 1A4, Transistor Dc voltage Measurements

Transistor stage	Dc voltage to ground		
	B	E	C
A1Q1-----	18.0	18.3	17.5
A1Q2-----	6.1	6.3	0
A1Q3-----	9.3	9.0	18.7
A1Q4-----	7.9	8.2	0
A1Q5-----	9.9	10.2	0
A1Q6**-----	20.0	20.0	14.2
A1Q7-----	4.8	5.1	0
A1Q8-----	6.4	6.6	0
A2Q1-----	10.1	10.5	0

See footnotes at end of table.

Table 3-17. 10 and 1 kHz Synthesizer Module 1A4, Transistor Dc Voltage Measurements—Continued

Transistor stage	Dc voltage to ground		
	B	E	C
A2Q2*	14.0	13.0	0
A2Q3	9.9	10.3	0
A2Q4	9.9	10.3	0
A2Q5*	19.0	19.0	7.5

*Biasing controlled by age voltage. Levels shown are typical.
 **In RT-662/GRC serial numbers 1 through 220, FR-36-039-B-6-31886 (E).

Table 3-18. 10- and 1-kHz Synthesizer Module 1A4, E-Terminal Voltage Measurements

Terminal	Voltage measurement
A1E1*	Noise blanking input -0.6 ± 0.2 volts peak-to-peak pulse (when noise blanker 1A1A6 is functioning) (AN/USM-281A).
A1E2	Ground.
A1E3	Not used.
A1E4	6.50- to 6.59-MHz sine wave at an amplitude of 1.4 ± 0.14 volts peak-to-peak (AN/USM-281A and AN/USM-207).
A1E5	Ground.
A1E6	1 kHz pulses with a time period of 1 millisecond and on amplitude of 1.0 ± 0.3 volt peak-to-peak (AN/USM-281A) (c, fig. 4-28).
A1E7	Ground.
A1E8	Ground.
A1E9	Keyed oscillator signal with an amplitude of 4.0 ± 0.5 volts peak-to-peak and amplitude of 1 kHz as shown in d and e, figure 4-28 (AN/USM-281A).
A1E10	6.50- to 6.59-MHz sine wave at an amplitude of 55 mv rms minimum (AN/USM-306 and AN/URM-145).
A1E11	19.5 ± 0.5 vdc (ME-26(*)/U).
A1E12	4.551- to 4.650-MHz sine wave at an amplitude of 120 ± 30 mv rms (AN/USM-306 and AN/URM-145).
A1E13	Ground.
A1E14	Ground.
A1E15	1.940- to 1.949-MHz sine wave at an amplitude of 1.7 ± 0.14 volt peak-to-peak (AN/USM-281A and AN/USM-207).
A1E16	6.50- to 6.50-MHz sine wave at an amplitude of 125 ± 25 mv rms (AN/USM-306).
A1E17	Complex wave at an amplitude of 2.3 ± 0.4 volts rms (AN/URM-145).
A1E18	4.551- to 4.650-MHz sine wave at an amplitude of 1.8 ± 0.3 volts rms (AN/URM-145).
A1E19	1.940- to 1.949-MHz sine wave at an amplitude of 100 ± 25 mv rms (AN/USM-306).
A2E1	Same as A1E11.
A2E2	Same as A1E10.

Table 3-18. 10- and 1-kHz Synthesizer Module 1A4, E-Terminal Voltage Measurements—Continued

Terminal	Voltage measurement
A2E3	Same as A1E9.
A2E4	Ground.
A2E5	Ground.
A2E6	Spectrum: 2.48 to 2.57 MHz in 10 kHz increments with an amplitude of 160 ± 10 mv peak-to-peak (AN/USM-281A and AN/USM-306) (f, fig. 4-28).
A2E7	7.1 MHz sine wave at an amplitude of ± 5 mv rms (AN/URM-145).
A2E8	Ground.
A2E9	Complex signal made up of 1.97 MHz and 9.07 MHz. The resultant has an amplitude of 85 ± 20 mv peak-to-peak and is illustrated in g, figure 4-28 (AN/USM-281A).
A3E1	Same as A1E4.
A3E2	Ground.
A4E1	Same as A1E15.
A4E2	Ground.

*In RT-662/GRC serial numbers 1 through 220, FR-36-039-B-6-31886 (E).

3-14. Transmitter IF and Audio Module 1A5

a. Transistor Dc Voltage Measurements. All measurements in table 3-19 should be within ± 20 percent of the indicated value. Refer to figures 3-24 through 3-26 for parts location.

b. E-Terminal Voltage Measurements. All voltage measurements in table 3-20 were taken with the test equipment listed in parentheses directly after the value. All measurements should be within ± 20 percent of the indicated value. Refer to figures 3-25 and 3-26 for terminal location.

Table 3-19. Transmitter IF and Audio Module 1A5, Transistor Dc Voltage Measurements

Transistor stage	Dc voltage to ground		
	B	E	C
Q1 receive	0.5	0	27
transmit	0.75	0	0.2
A1Q1*	0	0	18
A1Q2*	0.65	0	0.05
A1Q3*	7.0	7.4	0
A1Q4**	0	0	18.0
A1Q5**	0.65	0	0.05
A1Q6**	7.8	7.5	0
A2Q1	0.75	0	0
A2Q2	2.7	2.3	12.5
A2Q3	12.5	13.4	9.6
A2Q4	9.5	0	0
A2Q5	8.6	0	0
A2Q6	0	0	19.5
A2Q7***	1.5	0.75	2.3

See footnotes at end of table.

Table 3-19. Transmitter IF and Audio Module 1A5, Transistor Dc Voltage Measurements—Continued

Transistor stage	Dc voltage to ground		
	B	E	C
A2Q8-----	0.65	0	5.5
A2Q9-----	0	12.8	12.8
A2Q10-----	12.8	12.5	0
A2Q11-----	0	0	13.0
A2Q12-----	0.75	0	0.07
	0.05	0	0
A3Q1 re-	3.3	0	19.5
ceive	2.3	0	19.5
transmit			
A3Q2 re-	3.2	3.0	19.5
ceive	2.3	1.8	19.5
transmit			
A3Q3 re-	2.8	2.5	19.5
ceive	1.8	0.6	19.5
transmit			
A3Q4-----	2.8	2.2	19.5
A3Q5-----	2.2	1.8	19.5

* No ppc signal applied (0 volts dc at terminal A1E1).
 ** No apc signal applied (0 volts dc at terminal A1E5).
 *** Cw mode of operation unkeyed.

Table 3-20. Transmitter IF and Audio Module 1A5, E-Terminal Voltage Measurements

Terminal	Voltage measurement
A1E1	Ppc voltage input at a level of 0 to 2.5 vdc depending on output RF signal level (ME-26(*)/U).
A1E2	1.75 MHz IF input at level of 1 ± 0.2 mv rms (AN/URM-145).
A1E3	Ground.
A1E4	19.5 ± 0.5 vdc in transmit and ground in receive (ME-26(*)/U).
A1E5	Apc voltage input at a level of 0 to 2.5 vdc depending on the output RF signal level (ME-26(*)/U).
A1E6	1.75 MHz am. carrier reinsertion signal at a level of 50 ± 5 mv rms (AN/URM-145).
A1E7	Ground.
A1E8	Ground.
A1E9	Not used.
A1E10	Not used.
A1E11	19.5 ± 0.5 vdc (ME-26(*)/U).
A1E12	Ground when the RT-834/GRC or RT-662/GRC is in am. mode.
A1E13	Ground when the AN/GRC-106 is in tune mode.
A1E14	1.75 MHz IF output at a level of up to 40 mv rms depending on the amount of apc and ppc control and the type of operation (AN/URM-145).
A1E15	Ground.
A2E1	19.5 ± 0.5 vdc (ME-26(*)/U).
A2E2	50-ohm microphone input at a level of 2 v rms (microphone output). Open circuit voltage of 19.5 ± 0.5 vdc; short circuit current of 35 ± 5 ma (TS-352B/U and ME-26(*)/U).

Table 3-20. Transmitter IF and Audio Module 1A5, E-Terminal Voltage Measurements—Continued

Terminal	Voltage measurement
A2E3	600-ohm microphone input at a level of 200 mv rms (AN/URM-145).
A2E4	Ground with unit keyed in the cw mode.
A2E5	19.5 ± 0.5 vdc in the cw mode (ME-26(*)/U).
A2E6	1 kHz pulsed input at a level of 1.5 ± 0.3 volt peak-to-peak (AN/USM-281A). Waveform is square until unit is keyed.
A2E7	Ground.
A2E8	Ground.
A2E9	Same as A2E4.
A2E10	Audio output at a level of 8.0 ± 3.0 mv rms (ME-26(*)/U).
A2E11	0 vdc when the vox switch is set at VOX or PUSH TO VOX with the key down, 0.6 vdc in any nonvox mode (key down), and 1.2 vdc receive, ssb (push-to-talk) (ME-26(*)/U).
A2E12	27 vdc (ME-26(*)/U).
A2E13	Ground when keyed in am., ssb, or nsk mode of operation, 0.7 vdc in any other condition (ME-26(*)/U).
A2E14	0.6 vdc in transmit and 0 vdc in receive (ME-26(*)/U).
A2E15	Not used.
A2E16	2.5 vdc maximum in transmit and 27 vdc in receive (ME-26(*)/U).
A2E17	2.5 vdc maximum in transmit and 27 vdc in receive (ME-26(*)/U).
A2E18	Ground in cw and fsk.
A2E19	Ground in cw.
A3E1	10.5 ± 0.5 vdc (ME-26(*)/U).
A3E2	2.5 vdc minimum (ME-26(*)/U).
A3E3	19.5 ± 0.5 vdc in receive and ground in transmit (ME-26(*)/U).
A3E4	2.5 vdc minimum (ME-26(*)/U).
A3E5	Ground.
A3E6	2.5 vdc minimum (ME-26(*)/U).
A3E7	Apc output at a level of 1.0 vdc minimum (ME-26(*)/U).
A3E8	Apc output at a level of 1.0 vdc minimum (ME-26(*)/U).
A3E9	Input to signal level meter in transmit at a level of 1.0 vdc minimum (ME-26(*)/U).

3-15. Frequency Dividers Module 1A6

a. *Transistor Dc Voltage Measurements.* All measurements in table 3-21 should be within ± 15 percent of the indicated value. Refer to figures 3-27 through 3-29 for parts location.

b. *E-Terminal Voltage Measurements.* All voltage measurements in table 3-22 were taken with the test equipment listed in parentheses directly after the value. Refer to figures 3-28 and 3-29 for terminal location.

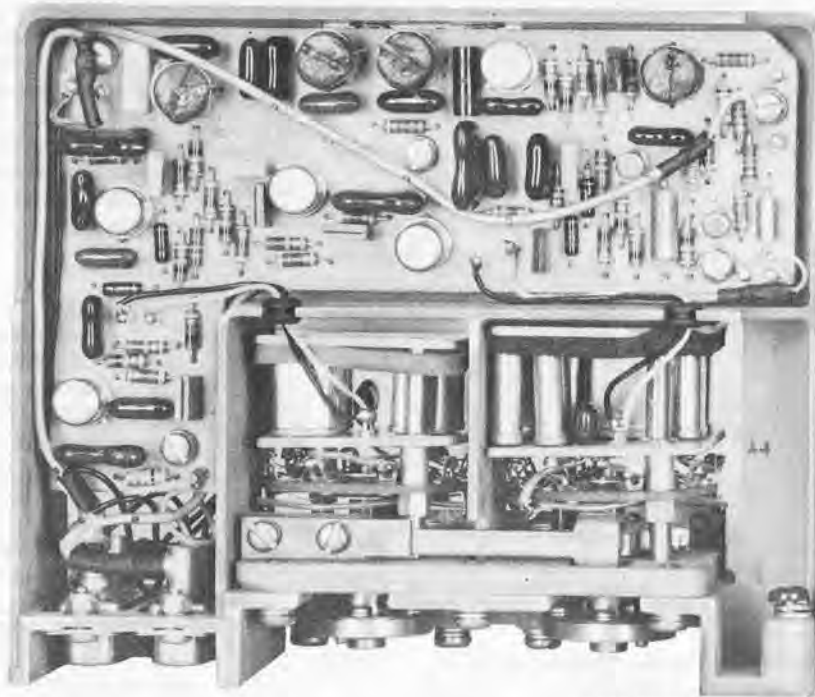

TM5820-520-35-737

Figure 3-21. 10 and 1 kHz synthesizer module 1A4, parts location.

Table 3-21. Frequency Dividers Module 1A6, Transistor Dc Voltage Measurements

Transistor stage	Dc voltage to ground		
	B	E	C
A1Q1	10.4	9.0	5.8
A1Q2	6.2	7.0	9.4
A1Q3	9.4	9.1	1.7
A1Q4	7.9	8.1	7.8
A1Q5	8.1	8.6	7.8
A2Q1	8.9	8.7	5.0
A2Q2	8.9	8.7	5.0
A2Q3	6.5	7.5	9.8
A2Q4	9.8	9.4	1.4
A2Q5	9.8	9.8	5.8
A2Q6	9.2	9.2	5.4
A2Q7	18.5	19.5	16.0
A2Q8	10.2	10.0	19.0
A2Q9*	3.6	3.9	0
A3Q1	8.5	8.4	4.8
A3Q2	8.5	8.4	4.8
A3Q3	6.6	7.3	9.3
A3Q4	9.4	9.0	1.3

* Measurements under FREQ VERNIER control set at ON.

NOTE:

AIR23 AND AICR6 ARE NOT IN THE RT-834/GRC NOR THE RT-662/GRC AFTER SERIAL NO. 220.

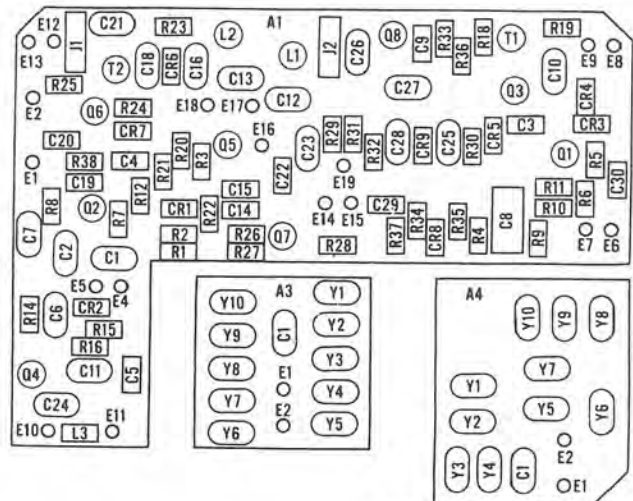

TM5820-520-35-738 (1)

Figure 3-22(1). RT-662/GRC printed circuit boards 1A4A1, 1A4A3, and 1A4A4, parts location diagram (serial numbers 1 through 220) FR-36-039-B-6-31886 (E) (sheet 1 of 2).

Table 3-22. Frequency Dividers, Module 1A6, E-Terminal Voltage Measurements

Terminal	Voltage measurement
A1E1	19.5 \pm 0.5 vdc (ME-26(*)/U).
A1E2	500-kHz sine wave with an amplitude of 190 \pm 40 mv rms (AN/USM-306).
A1E3	Ground.
A1E4	100-kHz pulses with a pulse repetition of 10 microseconds, pulse width of 1 \pm 0.2 microsecond at 50% amplitude, and amplitude of approximately 7 volts peak-to-peak (AN/USM-281A).
A1E5	100-kHz pulses with a pulse repetition rate of 10 microseconds, pulse width of 1 \pm 0.2 microsecond at 50% amplitude, and amplitude of 0.75 \pm 0.15 volt peak-to-peak (AN/USM-281A) (h and i, fig. 4-28).
A1E6	Spectrum: 15.3 to 16.2 MHz in 100-kHz increments; pulse width of 0.75 \pm 0.1 microsecond at 50% amplitude; amplitude of 20 \pm 10 mv per spectrum point (AN/USM-306) (j and k, fig. 4-28).
A1E7	Ground.
A2E1	19.5 \pm 0.5 vdc (ME-26(*)/U).
A2E2	19.5 \pm 0.5 vdc (ME-26(*)/U).
A2E3	Same as A1E4.
A2E4	10-kHz pulses with a pulse repetition of 100 microseconds, pulse width of 10 \pm 2 microseconds at 50% amplitude, and an amplitude of 8 \pm 2 volts peak-to-peak (AN/USM-281A).
A2E5	50-kHz square wave with a pulse repetition of 20 microseconds, and an amplitude of 1.6 \pm 0.3 volt peak-to-peak (AN/USM-281A) (l and m, fig. 4-28).
A2E6	10-kHz pulses with a pulse repetition of 100 microseconds, pulse width of 10 \pm 2 microseconds at 50% amplitude, and an amplitude of 0.75 \pm 0.1 volt peak-to-peak (AN/USM-281A) (n and o, fig. 4-28).
A2E7	2.53-MHz sine wave with an approximate amplitude of 0.66 volt rms (FREQ VERNIER control at ON and centered) (AN/USM-306).
A2E8	2.53 MHz sine wave with an amplitude of approximately 6.7 mv rms (FREQ VERNIER control at ON and centered) (AN/USM-306).
A2E9	19.5 \pm 0.5 vdc (ME-26(*)/U).
A2E10	0 to 19.5 vdc (ME-26(*)/U).
A2E11	1.75 MHz sine wave with an amplitude of 50 \pm 5 mv rms (AN/USM-306).
A2E12	Ground.
A2E13	Spectrum (FREQ VERNIER control at OFF): 2.48 to 2.57 MHz in 10 kHz

Table 3-22. Frequency Dividers, Module 1A6, E-Terminal Voltage Measurements—Continued

Terminal	Voltage measurement
	increments; pulse width of 12 microseconds, at 50% amplitude; amplitude of 2.4 \pm 1.2 mv per spectrum point (p and q, fig. 4-28) (AN/USM-306).
	Spectrum (FREQ VERNIER control at ON): 2.48 to 2.57 MHz in 10 kHz increments with an amplitude of 4 \pm 2 mv per spectrum point (r and s, fig. 4-28) (AN/USM-306).
A2E14	Ground.
A2E15	0 to \pm 7 vdc (ME-26(*)/U).
A2E16	Ground.
A3E1	19.5 \pm 0.5 vdc (ME-26(*)/U).
A3E2	Same as A2E4.
A3E3	1 kHz pulses with a pulse repetition of 1 millisecond, pulse width 5 \pm 2 microseconds at 50% amplitude, and an amplitude of 1.5 \pm 0.5 volt peak-to-peak (AN/USM-281A) (t and u, fig. 4-28).
A3E4	Ground.
A3E5	Same as A3E3, except pulse width is 100 \pm 20 microseconds at 50% amplitude.
A3E6	Ground.

3-16. Receive IF and Audio Module 1A7

a. *Transistor Dc Voltage Measurements.* All the readings in table 3-23 should be within \pm 20 percent of the indicated value unless otherwise specified. Refer to figures 3-30 through 3-32 for parts location.

NOTE

Transistors A1Q1 through A1Q5 and A2Q1 through A2Q10 were measured with the RT-834/GRC or RT-662/GRC in the receive mode of operation and the agc circuit turned on. Transistors A3Q1, A3Q2, and A3Q3 were measured with the RT-834/GRC or RT-662/GRC in the receive mode of operation and the SERVICE SELECTOR switch set at CW. Transistors A4Q1 and A4Q2 were measured with the RT-834/GRC or RT-662/GRC keyed and in a transmit condition.

b. *E-Terminal Voltage Measurements.* All voltage measurements in table 3-24 were taken with the test equipment listed in parentheses directly after the value. Refer to figures 3-31 and 3-32 for terminal location.

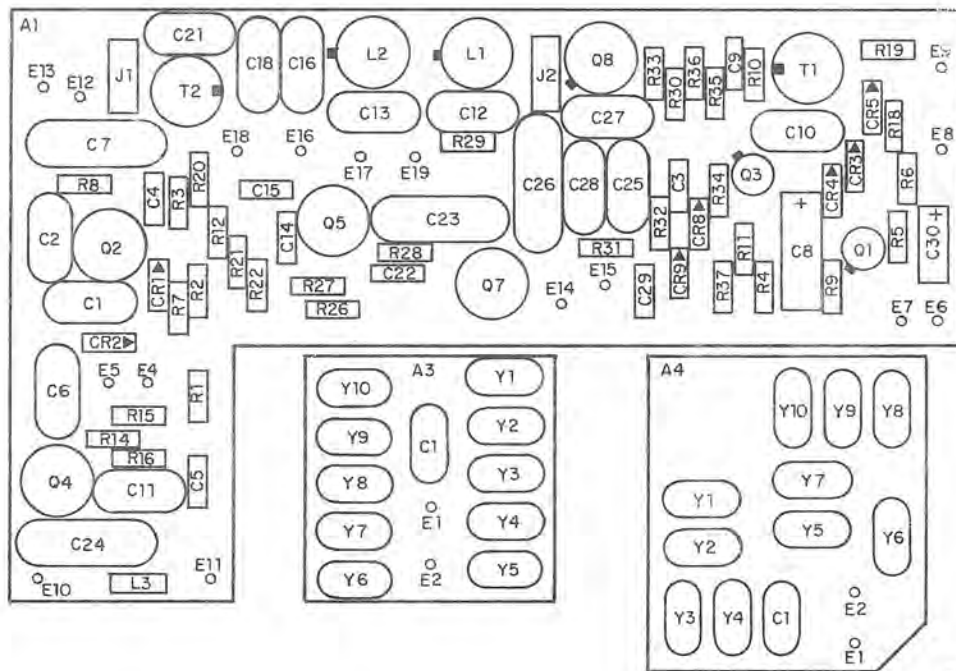

TM5820-520-35-738(2)

Figure 3-22(2). RT-662/GRC (after serial number 220) FR-36-039-B-6-31886(E), and RT-834/GRC printed circuit boards 1A4A1, 1A4A3, and 1A4A4, parts location diagram (sheet 2 of 2).

Table 3-23. Receiver IF and Audio Module 1A7, Transistor Dc Voltage Measurements

Transistor stage	Dc voltage to ground		
	B	E	C
A1Q1	0	0	16.5
A1Q2	6.8	7.0	0
A1Q3	0.7	0	0.04
A1Q4	6.8	7.0	0
A1Q5	7.0	7.4	0
A2Q1	6.8	7.1	0
A2Q2	7.2	7.4	0
A2Q3	4.0	4.0	19.5 ± 0.5
A2Q4	4.0	3.2	0
A2Q5	3.2	2.5	19.5 ± 0.5
A2Q6	2.5	2.0	19.5 ± 0.5
A2Q7	0.8	1.4	1.2
A2Q8	1.4	0.86	19.5 ± 5.0
A2Q9	1.4	0.86	19.5 ± 0.5
A2Q10	0.98	0.34	7.4
A3Q1	5.2	5.8	8.8
A3Q2	8.5	7.9	18.5
A3Q3	8.0	19.0	18.5
A4Q1	7.4	7.6	0
A4Q2	0.9	0.3	0.32

Table 3-24. Receiver IF and Audio Module 1A7, E-Terminal Voltage Measurements

Terminal	Voltage measurement
A1E1	Ground.
A1E2	Receive IF at a level of 1 mv rms (AN/URM-145).
A1E3	Ground.
A1E4	Receive IF at a level of 0.58 mv rms (AN/URM-145).
A1E5	IF agc at a level of 1 to 5 vdc (ME-26(*)/U).
A1E6	Not used.
A1E7	Ground.
A1E8	Receive IF output at a level of 24 ± 3, with 1 mv rms at A4E5 (AN/URM-306).
A1E9	Receive IF at a level of 3.2 ± 1.5 mv rms (AN/URM-145).
A1E10	Same as A1E9, balanced within 0.2 mv.
A1E11	Not used.
A1E12	19.5 ± 0.4 vdc (ME-26(*)/U).
A1E13	19.5 ± 0.5 vdc in cw only (ME-26(*)/U).
A2E1	Ground.
A2E2	RF agc output at a level from 0 to -24 vdc minimum negative (ME-26(*)/U).
A2E3	Audio output at a level of 750 ± 150 mv rms (AN/URM-145).
A2E4	1.75 MHz injection at a level of 4 ± 2 mv rms (AN/URM-145).
A2E5	Ground.
A2E6	19.5 ± 0.5 vdc (ME-26(*)/U).

Table 3-24. Receiver IF and Audio Module 1A7, E-Terminal Voltage Measurements—Continued

Terminal	Voltage measurement
A2E7	0 to 19.5 ±0.5 vdc, depending on setting of MANUAL RF GAIN control (ME-26(*)/U).
A2E8	-80 vdc (ME-26(*)/U).
A2E9	19.5 ±0.5 vdc (when age switch is on) (ME-26(*)/U).
A2E10	Same as A1E9.
A2E11	Same as A1E9.
A3E12	Not measurable.
A2E13	Same as A1E5.
A2E14	Same as A2E4.
A3E1	2.9 to 19.5 ±0.5 vdc depending on setting of the BFO control (ME-26(*)/U).
A3E2	0 to 20 vdc depending on setting of the BFO control and A3R4 (ME-26(*)/U).
A3E3	19.5 ±0.5 vdc (ME-26(*)/U), cw only.
A3E4	19.5 ±0.5 vdc (ME-26(*)/U).
A3E5	1.75 MHz injection at a level of 50 ±5.0 mv rms (AN/URM-145).
A3E6	Ground.
A3E7	Same as A2E4.
A3E8	Ground.
A4E1	Same as A3E5.
A4E2	Ground in receive and 20 vdc in transmit (ME-26(*)/U).
A4E3	Ground.
A4E4	Ground.
A4E5	1.75 MHz IF input at a level of 3.2 ±1 mv rms (AN/URM-145).
A4E6	Not used.
A4E7	19.5 ±0.5 vdc (ME-26(*)/U).
A4E8	Not used.
A4E9	Ground.
A4E10	If output to ssb crystal filter at a level of 2.4 ±1 mv rms (AN/URM-145).
A4E11	Audio input at a level of 8.0 ±2.0 mv rms (AN/URM-145).
A4E12	Ground when AN/GRC-106(*) is in a tune condition.

3-17. MHz Synthesizer Module 1A9

a. *Transistor Dc Voltage Measurements.* All measurements in table 3-25 should be within 15 percent of the indicated value. Refer to figures 3-33 through 3-36 for parts location.

b. *E-Terminal Voltage Measurements.* The voltage measurements in table 3-26 were made with the instrument indicated in parentheses after the value. Refer to figures 3-34 through 3-36 for terminal location.

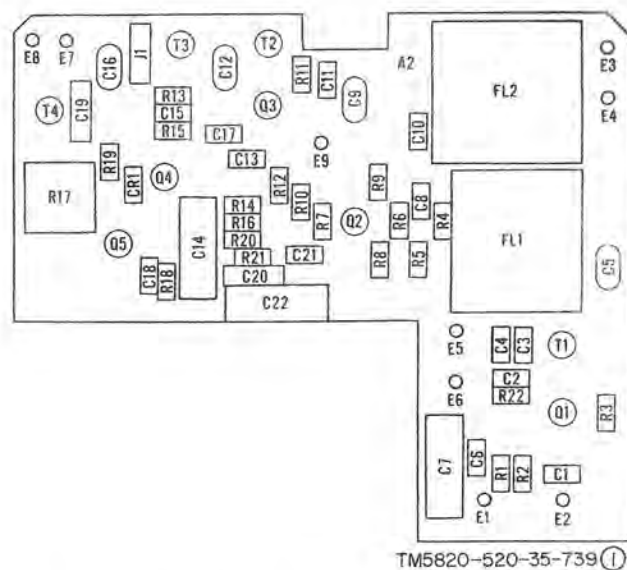

Figure 3-23(1). RT-662/GRC printed circuit board 1A4A2, parts location diagram (serial numbers 1 through 220), FR-36-039-B-6-31886(E) (sheet 1 of 2).

Table 3-25. MHz Synthesizer Module 1A9, Transistor Dc Voltage Measurements

Transistor stage	Dc voltage to ground		
	B	E	C
A1Q1	8.5	8.45	3.25
A1Q2	2.9	0.2	5.5
A1Q3	3.2	3.05	0
A2Q1	7.25	7.55	0
A2Q2	8.2	8.45	0
A2Q3	0.3	-0.2	9.6
A2A1Q1		Not measurable	Not measurable
A3Q1	3.9	4.2	0
A3Q2	2.1	2.4	0
A3Q3	5.5	5.88	0

Table 3-26. MHz Synthesizer Module 1A9, E-Terminal Voltage Measurements

Terminal	Voltage measurement
A1E1	19.5 ±0.5 vdc (ME-26(*)/U).
A1E2	1 MHz sine wave at an amplitude of 500 ±80 mv rms (AN/URM-145).
A1E3	Ground.
A1E4	2.4- to 23.5-MHz sine wave at an amplitude of 110 ±30 mv rms (AN/URM-145) and a 1-MHz pulse at a minimum amplitude of 220 ±50 mv peak above sine wave (AN/USM-281A) (v, fig. 4-28).
A2E1	19.5 ±0.5 vdc (ME-26(*)/U).
A2E2	Same as A1E4.

Table 3-26. MHz Synthesizer Module 1A9, E-Terminal Voltage Measurements—Continued

Terminal	Voltage measurement
A2E3	1.5-MHz, two-tone signal at an amplitude of 270 ± 40 mv rms (AN/URM-145) (w, fig. 4-28).
A2E4	1.5-MHz, two-tone wave at an amplitude of 130 ± 20 mv peak-to-peak (AN/USM-281A).
A2E5	1.5-MHz, two-tone wave at an amplitude of 4.0 ± 0.5 v peak-to-peak (AN/USM-281A).
A2E6	-0.30 to 0 vdc.
A2E7	9.0 to 17.0 vdc (ME-26(*)/U).
A2E8	Same as A2E7.
A2E9	Ground.
A2E10	2.5- to 23.5-MHz, sine wave at an amplitude of 13 ± 4 mv rms (AN/URM-145).
A2E11	Ground.
A3E1	19.5 ± 0.5 vdc (ME-26(*)/U).
A3E2	Same as A2E7.
A3E3	Ground.
A3E4	Circuit is too critical to measure accurately.
A3E5	2.5- to 23.5-MHz sine wave at an amplitude of 130 ± 20 mv rms (AN/URM-145).
A3E6	Ground.
A3E7	Same as A2E10.
A3E8	2.5- to 23.5-MHz sine wave at an amplitude of 60 ± 20 mv rms when transmitting and 50 ± 20 mv rms when receiving (AN/URM-145).
A3E9	Ground.

Table 3-26. MHz Synthesizer Module 1A9, E-Terminal Voltage Measurements—Continued

Terminal	Voltage measurement
A3E10	Ground or 19.5 ± 0.5 vdc (ME-26(*)/U).
A3E11	Ground.
A3E12	Ground.
A4E1	Ground.
S1A-30	Same as A3E4.
A5E1	Ground.
S1B-30	Same as A3E5.
S1C-15	19.5 ± 0.5 vdc (ME-26(*)/U).
S1C-25	Ground.
S1C-30	Ground or 19.5 ± 0.5 vdc (ME-26(*)/U).

3-18. Receiver Audio Module 1A10

a. *Transistor Dc Voltage Measurements.* All the readings in table 3-27 should be within ± 20 percent of the indicated value. Unless otherwise specified, all measurements were taken with the SQUELCH switch set at OFF, and no signal input. Refer to figures 3-37 through 3-39 for parts location.

b. *E-Terminal Voltage Measurements.* All voltage measurements in table 3-28 were taken with the SQUELCH switch set at OFF. Refer to figures 3-38 and 3-39 for terminal location.

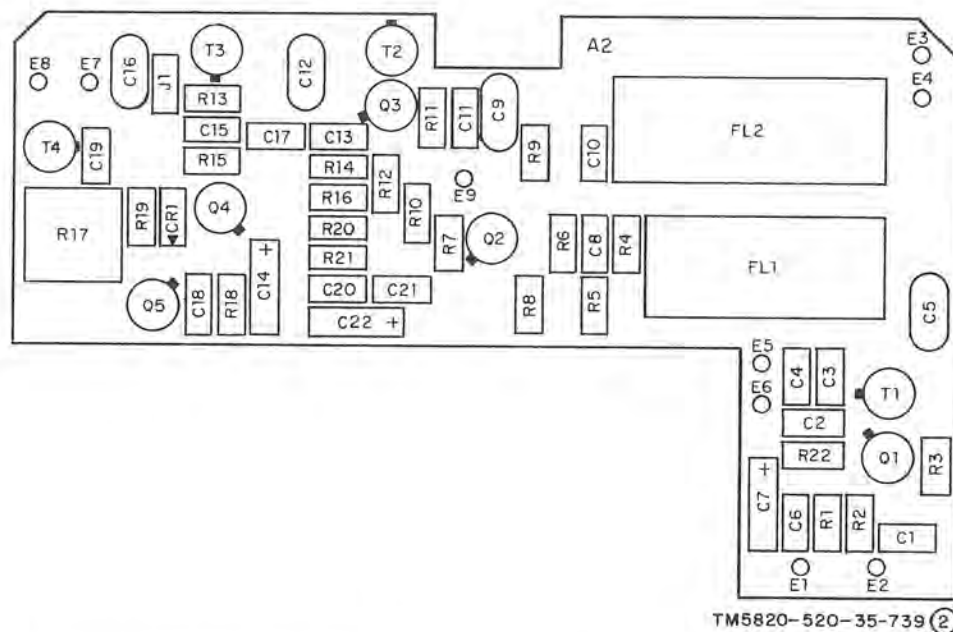
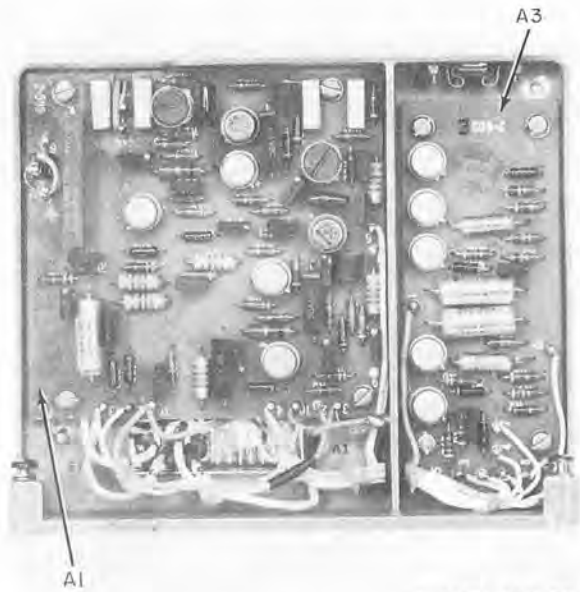
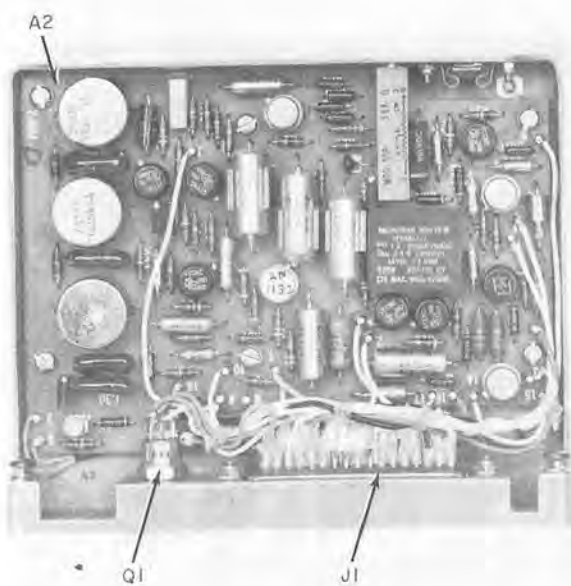
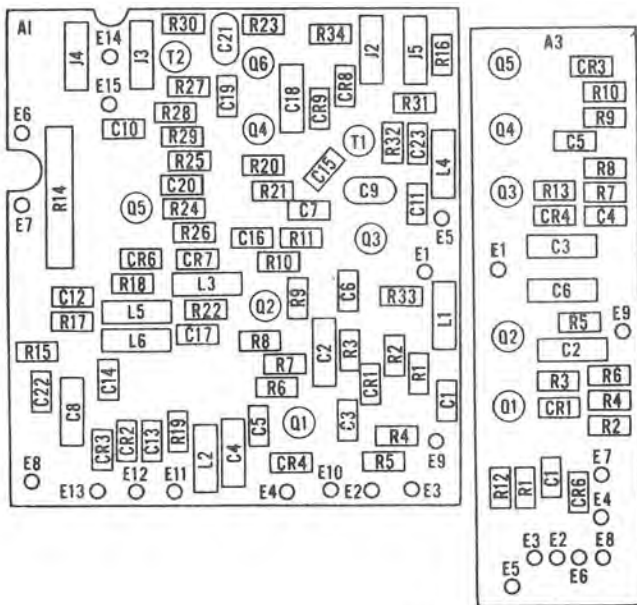

Figure 3-23(2). RT-662/GRC (after serial number 220) FR-36-039-B-6-31886(E), and RT-834/GRC printed circuit board 1A4A2, parts location diagram (sheet 2 of 2).



TM5820-520-35-740

Figure 3-24. Transmitter and Audio Module 1A5, parts location.



TM5820-520-35-741

Figure 3-25. Printed circuit boards 1A5A1 and 1A5A3, parts location diagram.

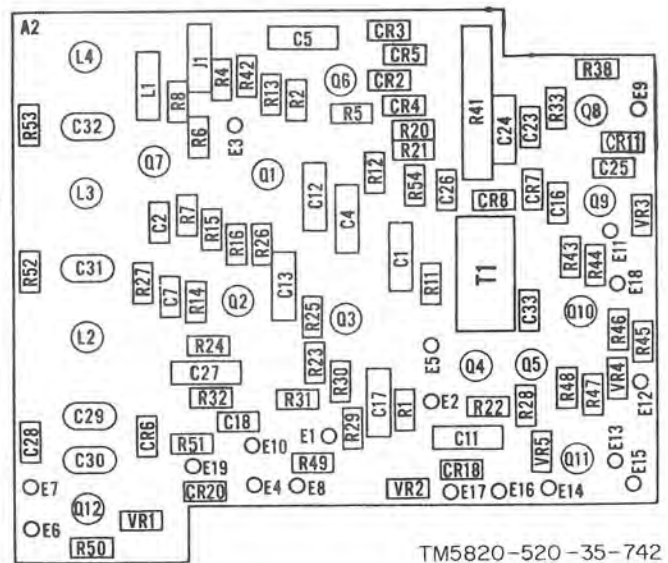

TM5820-520-35-742

Figure 3-26. Printed circuit board 1A5A2, parts location diagram.

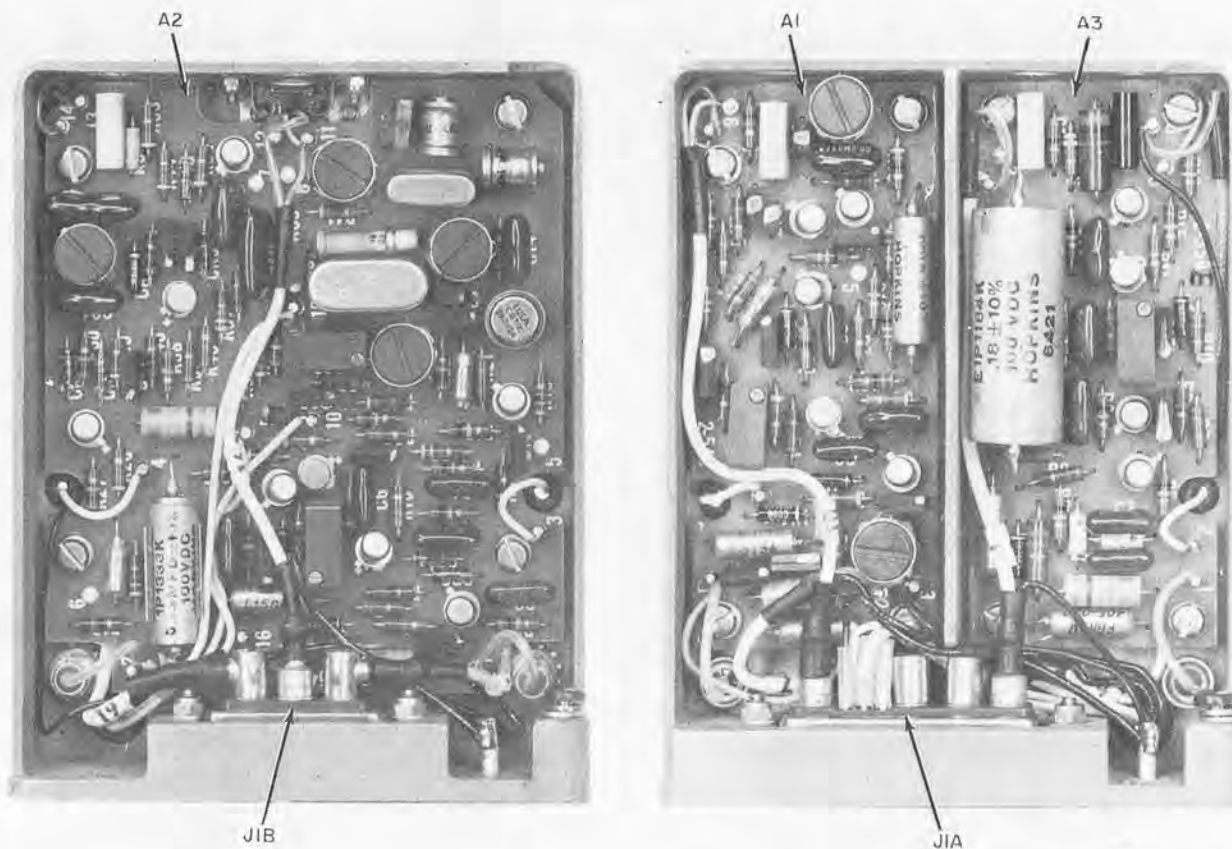

TM5820-520-35-743

Figure 3-27. Frequency divider module 1A6, parts location.

3-19. Dc-to-Dc Converter Module 1A11

NOTE

Apply heat sink compound when replacing the transistors in the 1A11 module.

a. *Transistor Dc Voltage Measurements.* All the readings in table 3-29 should be within ± 5 percent of the indicated value unless otherwise specified. Refer to figures 3-40 through 3-43 for parts location.

b. *E-Terminal Voltage Measurements.* The dc voltage measurements in table 3-30 were made with an ME-26(*)/U and the peak-to-peak measurements with an oscilloscope. Refer to figures 3-41 through 3-43 for terminal location.

Table 3-27. Receiver Audio Module 1A10, Transistor Dc Voltage Measurements

Transistor stage	Dc voltage to ground		
	B	E	C
Q1	14.0	14.5	19.5
Q2	10.5	10.9	20.0
Q3A	0.1	0.64	26.0
Q3B	0.1	0.64	26.0
A1Q1	0	0	0
A1Q2	0.5	1.0	14.0
A1Q3	0	0	19.5
A1Q4	8.1	8.1	20.0
A2Q1	^a 0	^a 0	^a 20.0
	^b 0	^b 0.6	^b 0
	^c 0	^c 0	^c 0
A2Q2	^a 0	(^d)	^a 20.0
	^b 0	(^d)	^b 20.0
A2Q3	^a 20.0	^a 18.5	^a 20.0
	^c 14.0	^c 14.0	^c 20.0

^a Squelched (SQUELCH switch set at ON).
^b Unsquelched with a 500-Hz signal input.
^c Unsquelched with ground applied at terminal A2E6.
^d Not measurable.

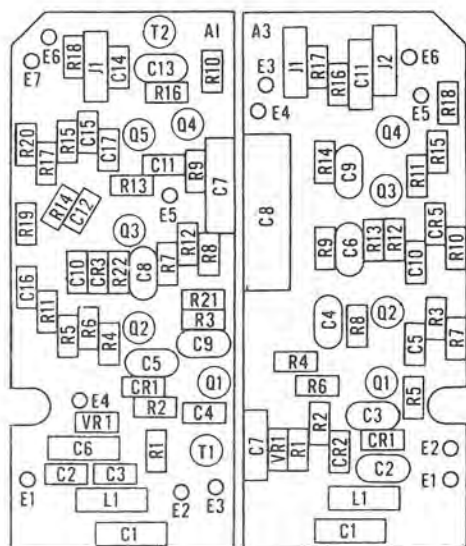

TM5820-520-35-744

Figure 3-28. Printed circuit Boards 1A6A1 and 1A6A3, parts location diagram.

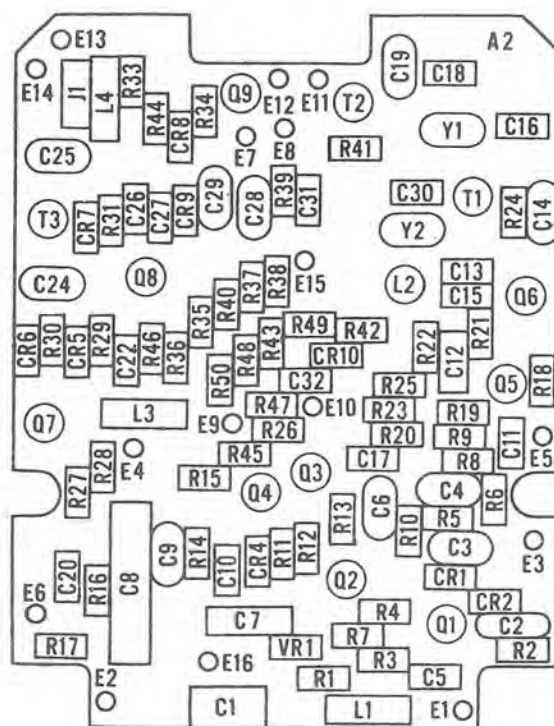

TM5820-520-35-745

Figure 3-29. Printed circuit board 1A6A2, parts location diagram.

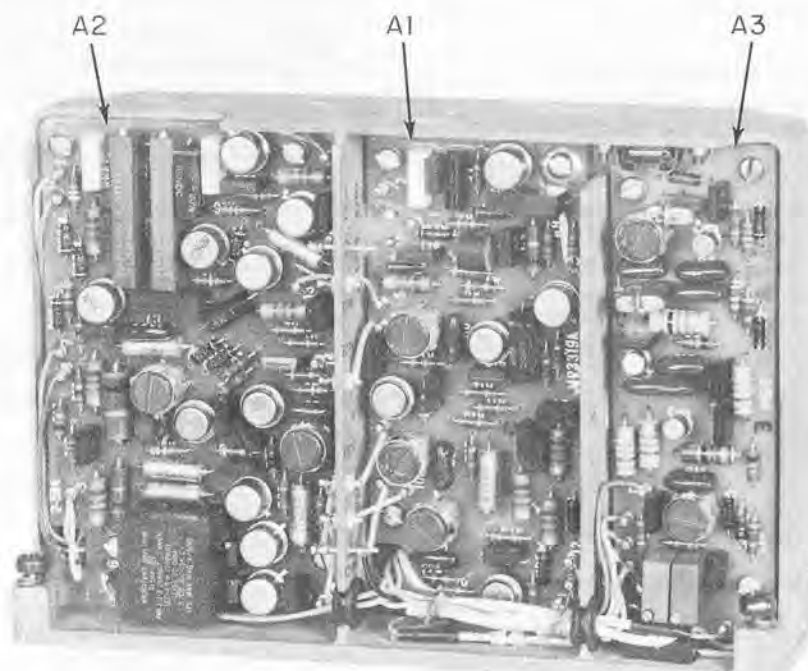

TM5820-520-35-746 ①

Figure 3-30(1). Receiver IF module 1A7, parts location (sheet 1 of 2).

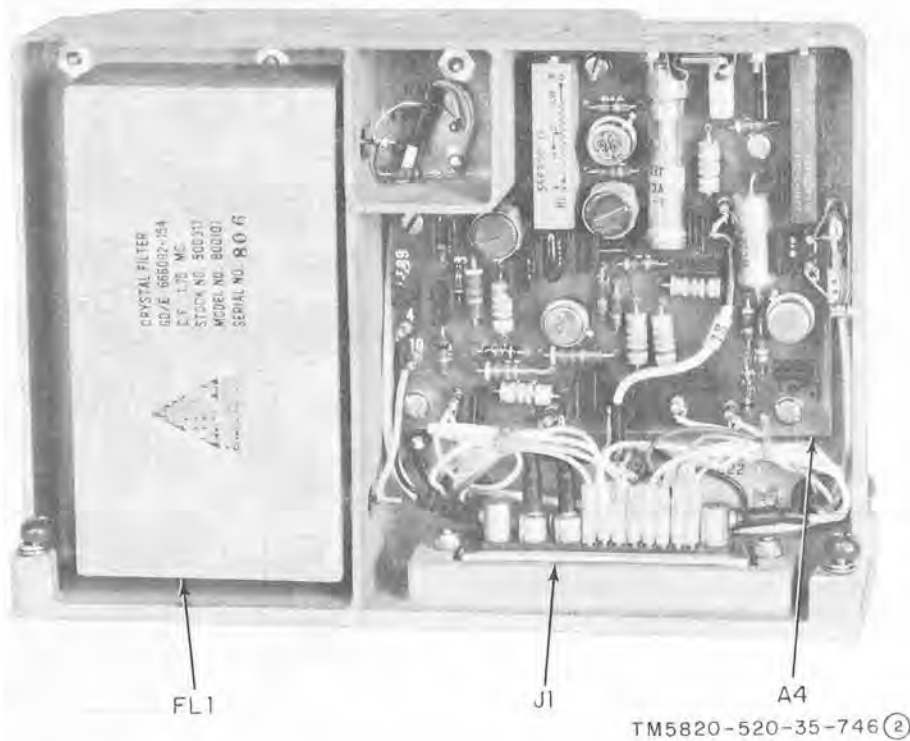

Figure 3-30(2). Receiver IF module 1A7, parts location (sheet 2 of 2).

Table 3-28. Receiver Audio Module 1A10, E-Terminal Voltage Measurements

Terminal	Voltage measurement
A1E1	Ground.
A1E2	Audio (300 to 3,500 Hz) input at a level between 0.6 and 1.0 v rms.
A1E3	19.5 ± 0.5 vdc in receive and ground in transmit.
A1E4	Audio (300 to 3,500 Hz) at a level between 0 and 250 mv rms.
A1E5	Audio (400 to 600 Hz) at a level up to 3.5 v rms. The level is frequency dependent.
A1E6	Up to 4.5 vdc. The level is frequency dependent (maximum approximately 500 Hz).
A2E1	19.5 ± 0.5 vdc.
A2E2	Audio input (300 to 3,500 Hz) at a level between 0.6 and 1.0 v rms.
A2E3	Ground.
A2E4	Audio (300 to 3,500 Hz) at a level between 125 and 250 mv rms.
A2E5	Not used.
A2E6	Ground with the SQUELCH switch set at OFF.
A2E7	Same as A1E4.
A2E8	Same as A1E5.
A2E9	Same as A1E6.
A2E10	Ground when operating in the cw or fsk mode.
A2E11	Audio (300 to 3,500 Hz) at a level between 125 and 250 mv rms.

Table 3-29. Dc-to-dc Converter 1A11, Transistor Dc Voltage Measurements

Transistor stage	Dc voltage to ground		
	B	E	C
Q1	6.0	0	27.0
Q2	6.0	0	27.0
A1Q1	26.0	27.0	20.0
A1Q2	11.5	11.5	26.0
A1Q3	4.8	4.0	11.5
A1Q4	4.8	4.0	20.0

Table 3-30. Dc-to-Dc Converter 1A11, E-Terminal Voltage Measurements

Terminal	Voltage measurement
A1E1	Ground.
A1E2	19.5 ± 0.2 vdc.
A1E3	20.7 ± 0.3 vdc.
A1E4	27.0 ± 3.0 vdc.
A2E1	27.0 ± 3.0 vdc.
A2E2	Ground.
A2E3	6.5 ± 0.5 v p-p.
A2E4	6.5 ± 0.5 v p-p.
A2E5	6.5 ± 0.5 v p-p.
A2E6	6.5 ± 0.5 v p-p.
A2E7	0.6 ± 0.2 vdc.
A2E8	27.0 ± 3.0 vdc.

Table 3-30. Dc-to-Dc Converter 1A11, E-Terminal Voltage Measurements—Continued

Terminal	Voltage measurement
A3E1	Ground.
A3E2	105 ± 10 v p-p.
A3E3	105 ± 10 v p-p.
A3E4	25 ± 5 v p-p.
A3E5	25 ± 5 v p-p.
A3E6	-33 ± 2 vdc.
A3E7	125 ± 10 vdc with 27 vdc input.
A3E8	125 ± 10 vdc with 27 vdc input.
A3E9	127 ± 10 vdc with 27 vdc input.

3-20. Transistor Dc Voltage Measurements, Circuit Board 2A4

All of the readings in table 3-31 were taken with an ME-26(*)/U and should be within ± 5 percent of the indicated value. Refer to figures 3-44 through 3-46 for part location.

Table 3-31. Printed Circuit Board 2A4, Transistor Dc Voltage Measurements

NOTE
Use ME-26(*)/U. Tolerance ± 5 percent.

Transistor stage	Dc voltage to ground		
	B	E	C
Q1	5.0 to 6.0	5.0	27
Q2	6.0	5.0 to 6.0	27

3-21. E-Terminal Voltage Measurements, Circuit Board 2A4

All measurements in table 3-32 were taken with an ME-26(*)/U. Refer to figures 3-44 through 3-46 for terminal location.

Table 3-32. Printed Circuit Board 2A4, E-Terminal Voltage Measurements

Terminal	Voltage measurement
A1E1	1.4 to 4.0 vdc
A1E2	Same as A1E2
A2E1	0.8 vdc
A2E2	Same as A2E1
A3E1	0.100 to 0.125 vdc
A3E2	27 ± 3 vdc
A3E3	Ground
A3E4	5.0 vdc

3-22. Filament Regulator 2A1A2

a. Transistor Dc Voltage Measurements. All readings in table 3-33 should be within ± 10 percent of the indicated value. Refer to figure 3-48 for parts location.

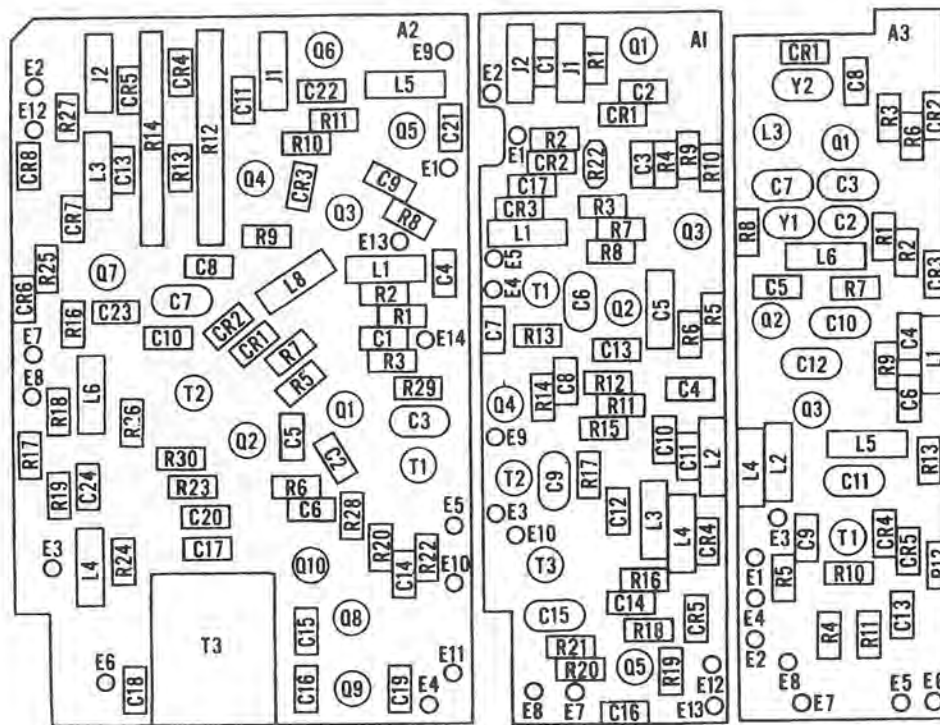

TM5820-520-35-747

Figure 3-31. Printed circuit boards 1A7A1, 1A7A2, and 1A7A3, parts location diagram.

Table 3-33. Filament Regulator 2A1A2, Transistor Dc Voltage Measurements

Transistor stage	Dc voltage to ground		
	B	E	C
2A1A2Q1	26	27	26
2A1A2Q2	11	10	26

b. E-Terminal Voltage Measurements. The voltage measurements in table 3-34 were taken with a ME-26(*)/U. Refer to figure 3-49 for terminal location.

Table 3-34. Filament Regulator 2A1A2, E-Terminal Voltages

Terminal	Voltage measurement
A2E1	+26 vdc
A2E2	Ground
A2A1E1	+27 vdc
A2A1E2	+11 vdc
A2A1E3	+11 vdc
A2A1E4	+24 vdc
A1A1E5	Ground

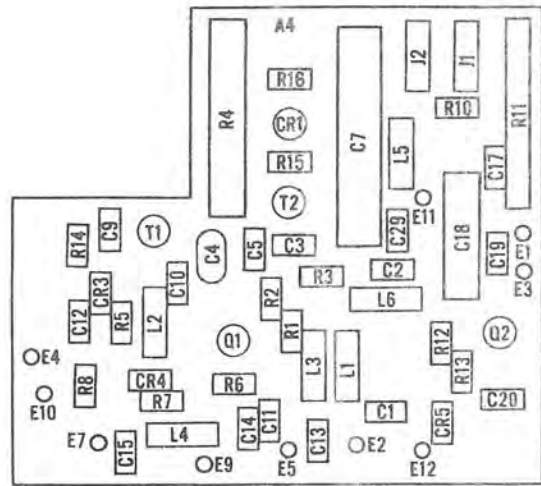

TM5820-520-35-748

Figure 3-32. Printed circuit board 1A7A4, parts location diagram.

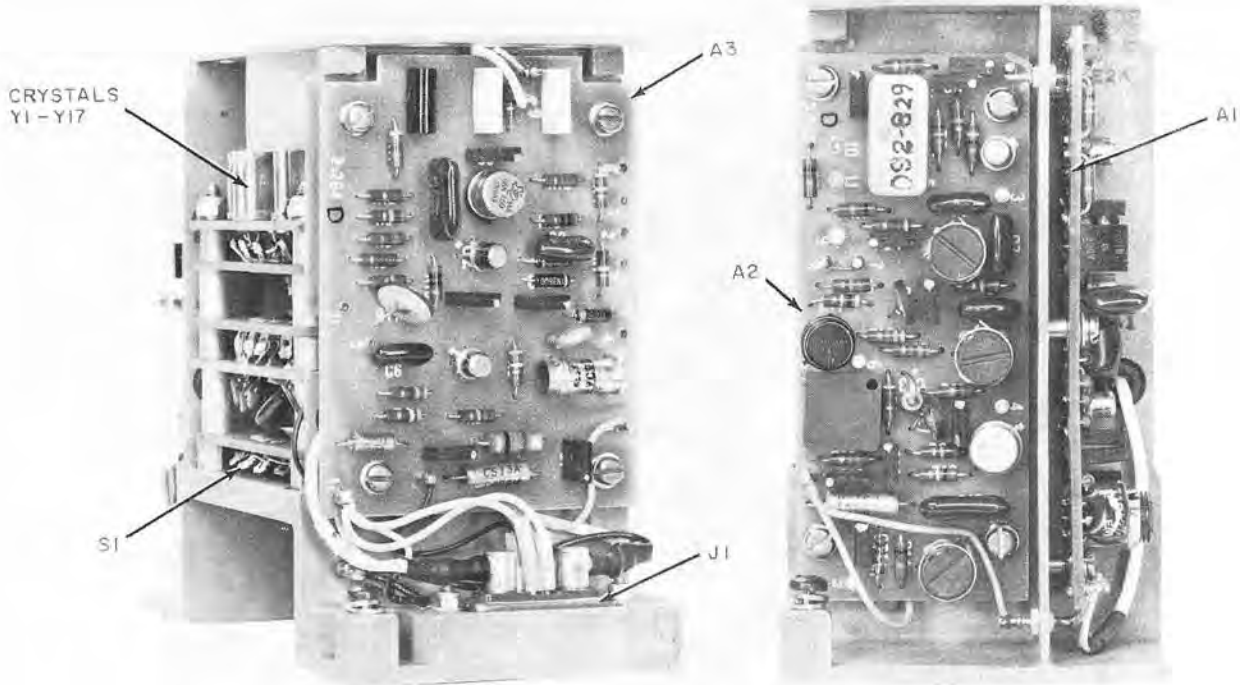

TM5820-520-35-752

Figure 3-33. MHz synthesizer module 1A9, parts location.

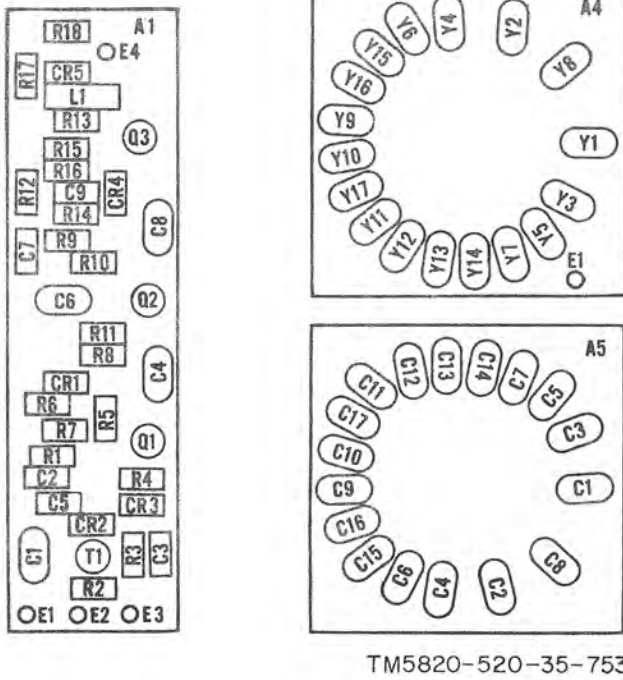

Figure 3-34. Printed circuit boards 1A9A1, 1A9A4, and 1A9A5, parts location diagram.

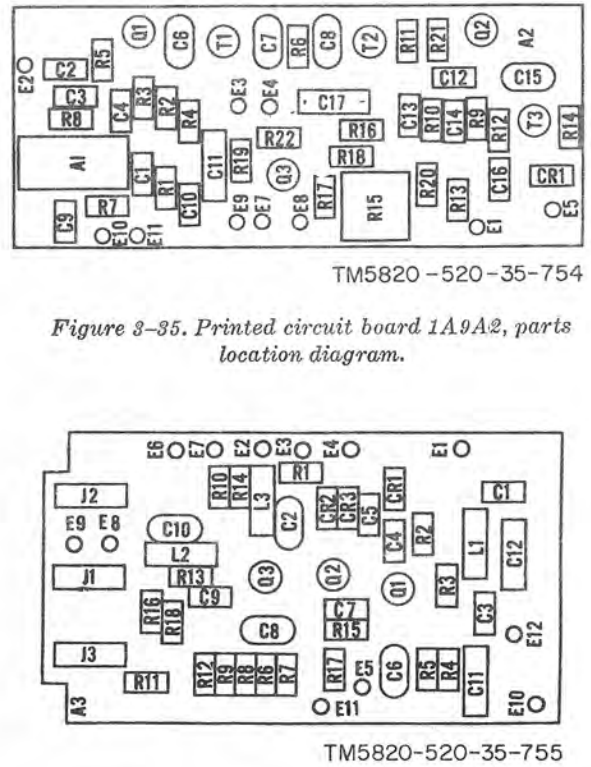
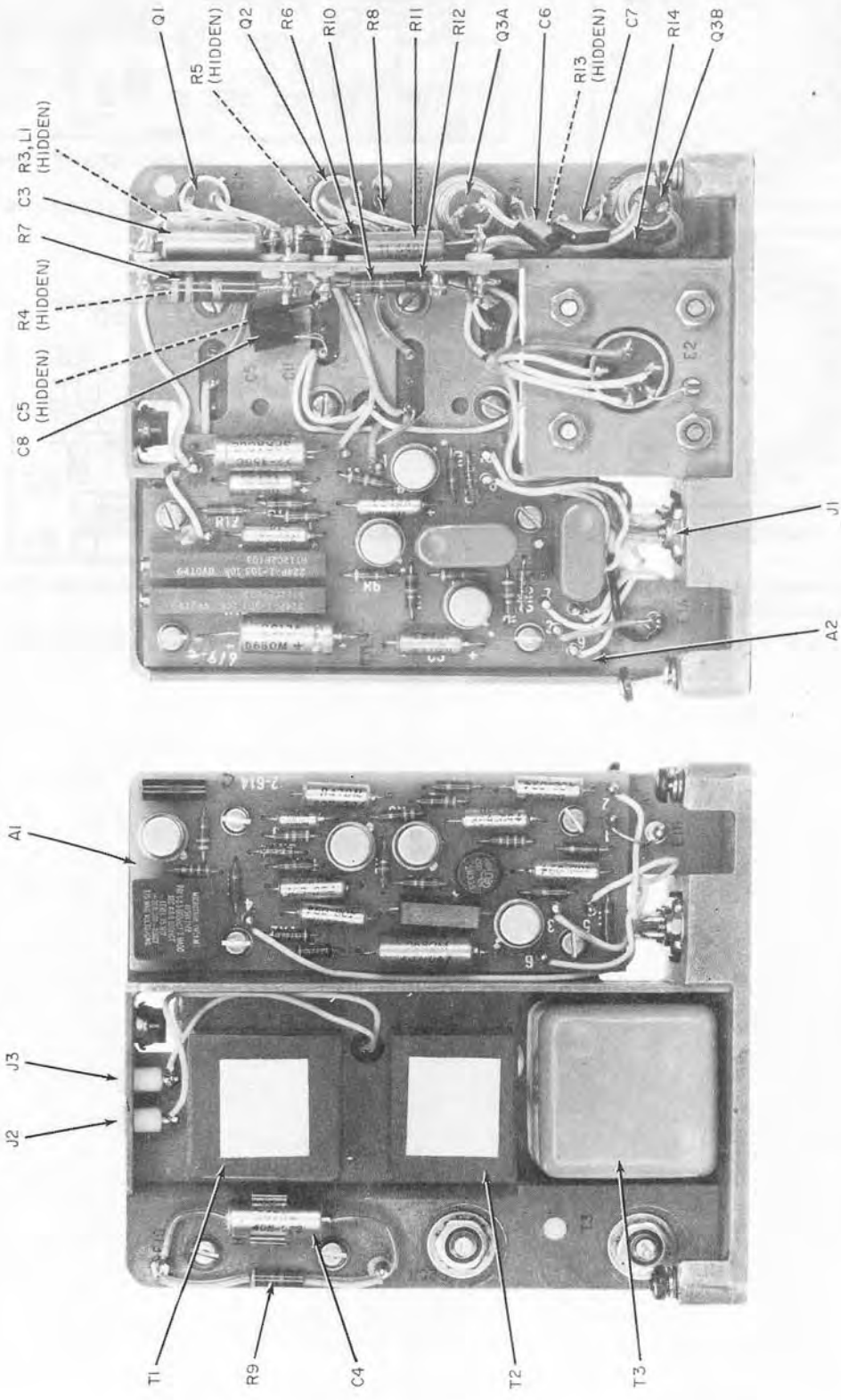

Figure 3-35. Printed circuit board 1A9A2, parts location diagram.

Figure 3-36. Printed circuit board 1A9A3, parts location diagram.



TM5820-520-35-756

Figure 3-37. Receiver audio module 1A10, parts location.

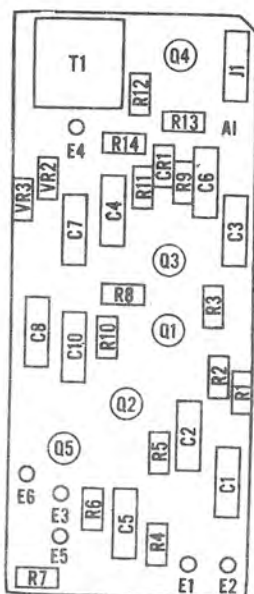

TM5820-520-35-757

Figure 3-38. Printed circuit board 1A10A1, parts location diagram.

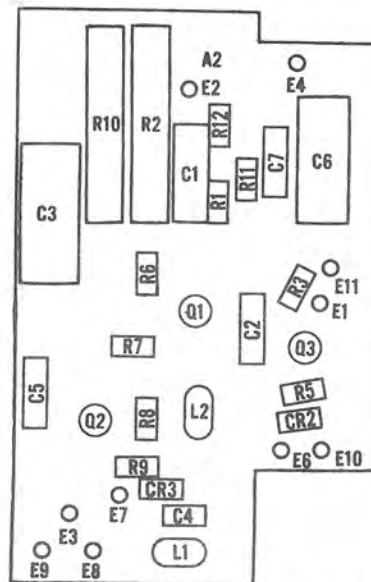

TM5820-520-35-758

Figure 3-39. Printed circuit board 1A10A2, parts location diagram.

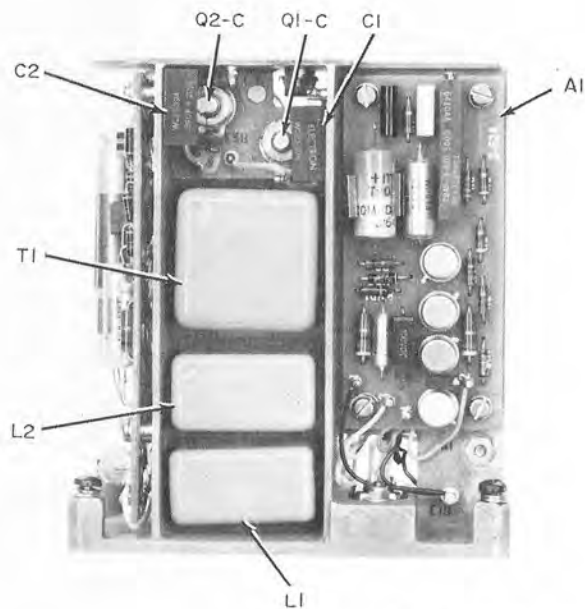
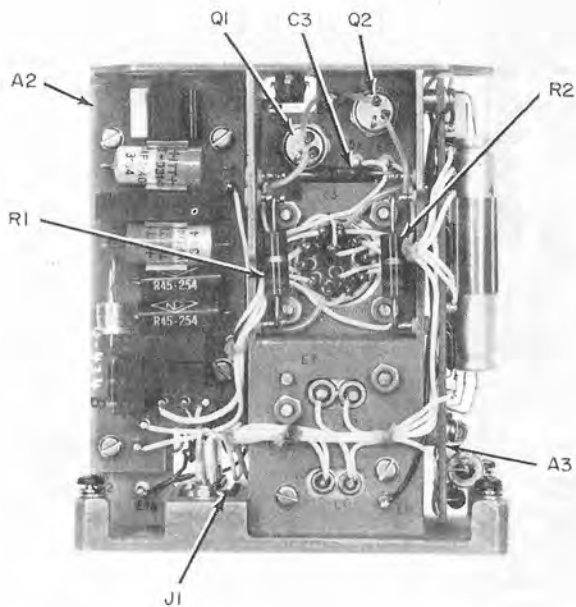

TM5820-520-35-759

Figure 3-40. Dc-to-dc converter module 1A11, parts location.

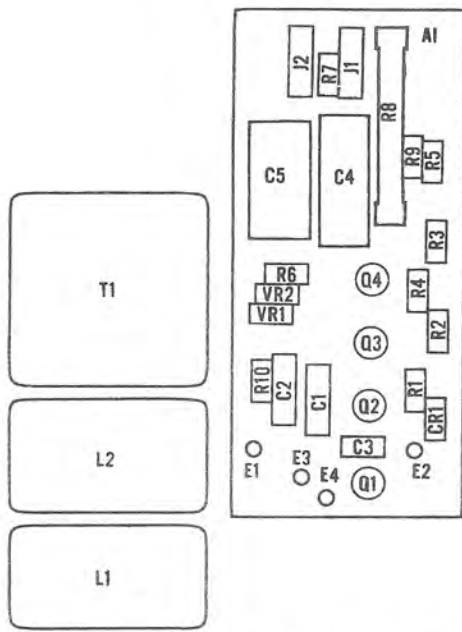

TM5820-520-35-760

Figure 3-41. Printed circuit board 1A11A1, parts location diagram.

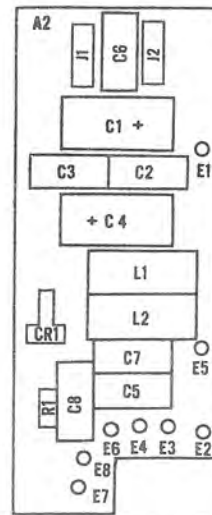

TM5820-520-35-761

Figure 3-42. Printed circuit board 1A11A2, parts location diagram.

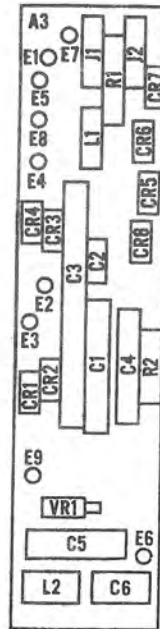

TM5820-520-35-762

Figure 3-43. Printed circuit board 1A11A3, parts location diagram.

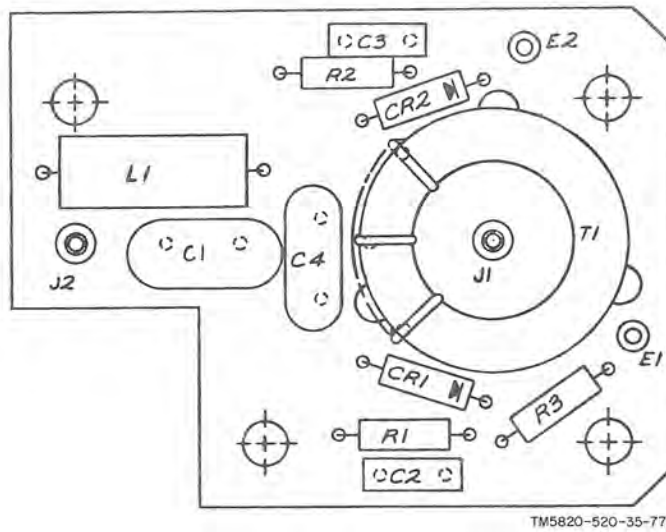

Figure 3-44. Printed circuit board 2A4A1, parts location diagram.

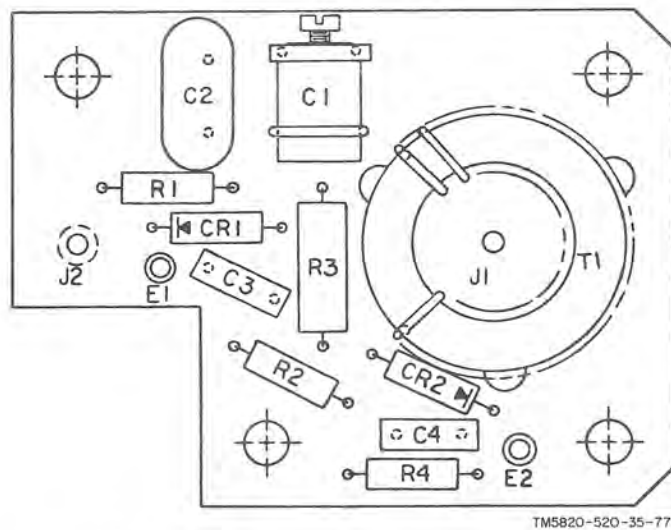

Figure 3-45. Printed circuit board 2A4A2, parts location diagram.

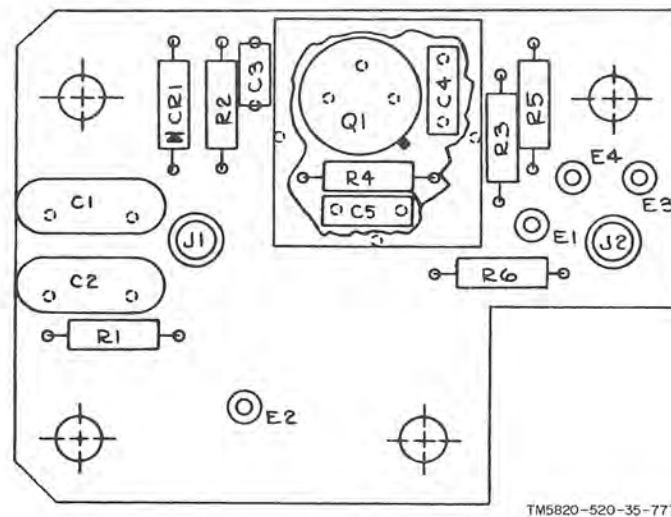

Figure 3-46. Printed circuit board 2A4A3, parts location diagram.

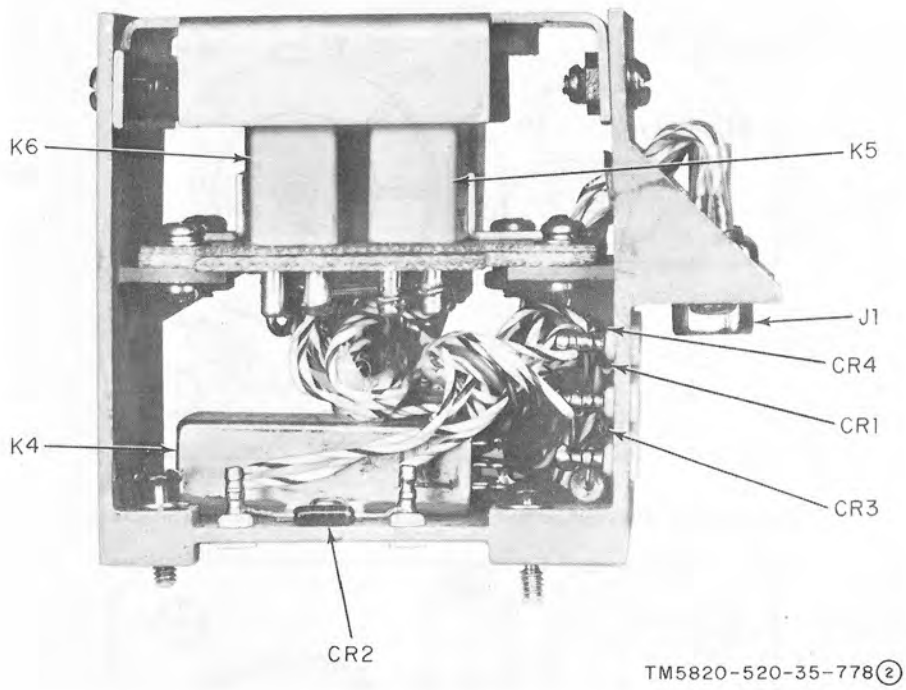

Figure 3-47(1). Relay assembly 2A7, parts location (sheet 1 of 2).

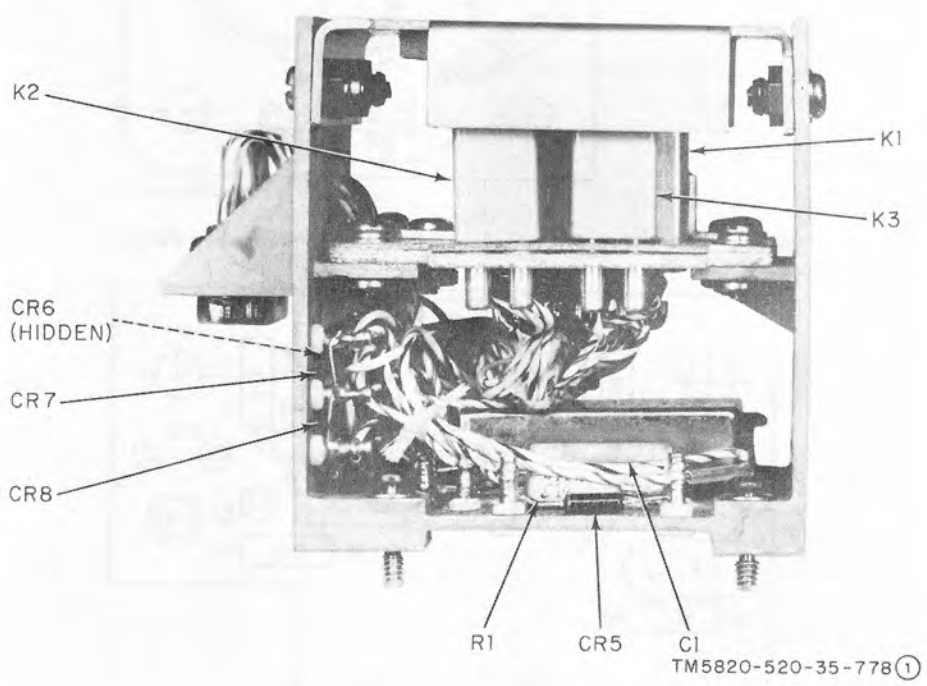
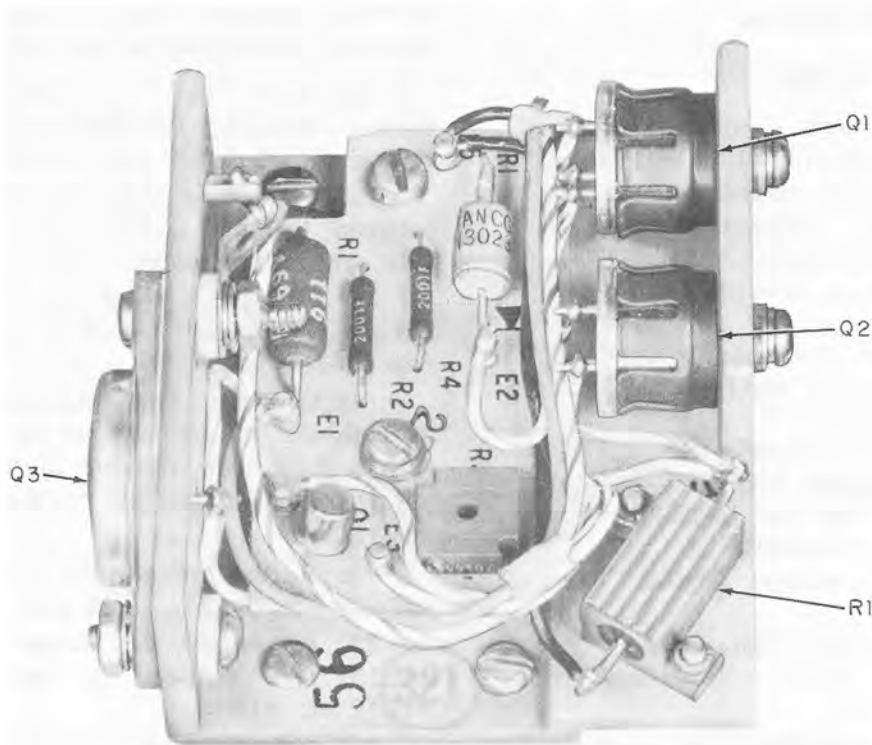
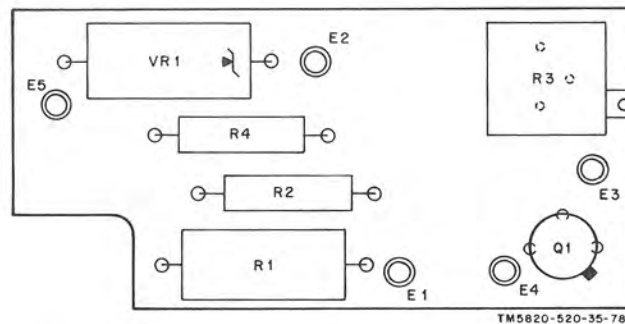

Figure 3-47(2). Relay assembly 2A7, parts location (sheet 2 of 2).



TM5820-520-35-779

Figure 3-48. Filament regulator 2A1A2, parts location.



TM5820-520-35-780

Figure 3-49. Filament regulator 2A1A2, terminal location.

Section III. MODULE ADJUSTMENTS

3-23. General

Paragraphs 3-24 through 3-34 cover electrical adjustment procedures for modules 1A2 through 1A10, and discriminator assembly 2A4. Complete test equipment nomenclature is covered in paragraph 3-2. Before adjusting rf coils or transformers, use toluene to soften the cement

on the ferrite cores before attempting adjustment.

CAUTION

Damage to ferrite cores will result if adjustment is attempted without first softening cement on rf coils and transformers.

3-24. 100 kHz Synthesizer Module 1A2 Adjustment Procedures

NOTE

For test point and component location refer to figures 4-37 through 4-40. For schematic diagram, refer to figure 4-35. No adjustment is required for transformers A1T1, A1T2, A1T7, A1T8, A1T9, and A2T3.

a. Test Equipment (1A2 Adjustment). Test equipment and materials required for 1A2 adjustment are listed below:

- (1) Voltmeter, Electronic AN/URM-145.
- (2) Generator, Signal AN/GRM-50.
- (3) Radio Test Set AN/USM-306.
- (4) Multimeter TS-352B/U.
- (5) Electronic Counter Digital Readout AN/USM-207.
- (6) Oscilloscope AN/USM-281A.
- (7) Simulator, Radio Frequency SM-442A/GRC.
- (8) Radio Set AN/GRC-106(*) modules:
 - (a) Frequency standard module 1A3.
 - (b) 10 and 1 kHz synthesizer module 1A4.
 - (c) Frequency dividers module 1A6.
 - (d) Translator module 1A8.
 - (e) MHz synthesizer module 1A9.
- (9) Two 0.01 microfarad, 50 volt capacitors.
- (10) One 3.3K ohm, 1/4 watt resistor.

b. Preparation (1A2 Adjustment). Perform the following preliminary procedures:

- (1) Turn on all the test equipment.
- (2) Connect tray A3 to the test set.
- (3) Make preliminary settings for the SM-442A/GRC according to instructions given in TM 11-6625-847-12.
- (4) Plug the 100 kHz synthesizer module 1A2 to be adjusted into tray A3.
- (5) Plug into tray A3, one known good spare module of each of the following: frequency standard module 1A3, 10 and 1 kHz synthesizer module 1A4, frequency dividers module 1A6, translator module 1A8 and MHz synthesizer module 1A9.
- (6) Set the test set SERV SEL switch to SSB/NSK and allow 30 minutes for the equipment to warm up.

c. Hi-Band Triple Tuned Filter Circuit Adjustment. Perform the procedures outlined in *b* above, then proceed as follows:

- (1) With the AN/USM-207, set the Signal Generator AN/GRM-50 for a cw output of 32.800 MHz \pm 15 kHz at 500 mv rms.
- (2) Connect a 0.01 microfarad capacitor between terminal A1E3 and ground on 100 kHz synthesizer module 1A2 (fig. 3-11).
- (3) Connect a short jumper between terminals A1E13 and A1E14 on 100 kHz synthesizer module 1A2.
- (4) Connect the AN/GRM-50 output through the 0.01 microfarad capacitor in series with a 3.3K ohm resistor to terminal A1E15.
- (5) Connect the AN/URM-145 to terminal A1E15.
- (6) Adjust transformer A1T5 for a peak indication on the AN/URM-145.
- (7) Disconnect the jumper from terminal A1E13 and connect it between terminals A1E12 and A1E14.
- (8) Adjust indicator A1L2 for a null indication on the AN/URM-145.
- (9) Remove the jumper from A1E12 and A1E14.
- (10) Adjust transformer A1T3 for a peak indication on the AN/URM-145.
- (11) Reconnect the jumper between terminals A1E13 and A1E14, and repeat (6) through (10) above to eliminate variations caused by interactions between the adjustments.
- (12) Disconnect the AN/GRM-50 from terminal A1E15, and reconnect it through the 0.01 microfarad capacitor to terminal A1E11. Set the rf signal generator to a 32.850 MHz output frequency and a level which provides a 50 mv rms indication on the AN/URM-145 connected to terminal A1E15.
- (13) Sweep the AN/GRM-50 frequency between 32.4 MHz and 33.3 MHz. The indication on the AN/URM-145 should not vary more than \pm 3 db from the 50 mv rms level established in 1 above.
- (14) If the AN/URM-145 indication varies more than \pm 3 db, shift the AN/GRM-50 frequency setting given in (1) above 50 kHz towards the end that falls off, and repeat the adjustment procedure until a variation of less than \pm 3 db is obtained.
- (15) Disconnect the test setup.

d. Lo-Band Triple Tuned Filter Circuit Adjustment. Perform the procedures outlined in *b* above, then proceed as follows:

(1) On the test set the MHz FREQ 10 MHz control to 0, the MHz FREQ 1 MHz control to 5, and the MHz FREQ .1 MHz control to 0.

(2) On tray A3, set the three FREQ SELECT controls to 0.

(3) With the AN/USM-207, set the AN/GRC-50 for a cw output of 22.800 MHz \pm 10 kHz at 500 mv rms.

(4) Connect a short jumper between terminals A1E18 and A1E19.

(5) Connect a 0.01 microfarad capacitor between terminal A1E3 and ground.

(6) Connect the AN/GRM-50 output through a 0.01 microfarad capacitor in series with a 3.3K ohm resistor to terminal A1E20.

(7) Connect the AN/URM-145 probe to terminal A1E20.

(8) Adjust transformer A1T6 for a peak indication on the AN/URM-145.

(9) Disconnect the jumper from terminal A1E18 and connect it between A1E19 and A1E17.

(10) Adjust the AN/GRM-50 for an output level of approximately 50 mv rms, as indicated on the AN/URM-145 connected to terminal A1E20.

(11) Adjust inductor A1L3 for a null on the AN/URM-145.

(12) Remove the jumper from terminals A1E17 and A1E19.

(13) Adjust transformer A1T4 for a peak indication on the AN/URM-145.

(14) Reconnect the jumper between terminals A1E18 and A1E19, and repeat (8) through (13) above to eliminate variations caused by interactions between the adjustments.

(15) Disconnect the AN/GRM-50 and reconnect it through a 0.01 microfarad capacitor to terminal A1E16. Set the AN/GRM-50 for an output of 22,850 MHz at a level which provides a 50 mv rms indication on the AN/URM-145 connected to terminal A1E20.

(16) Sweep the AN/GRM-50 output frequency between 22.4 and 23.3 MHz. The indication on the AN/URM-145 should not vary more than \pm 3 db from the 50 mv rms level.

(17) If the AN/URM-145 indications do not vary more than \pm 3 db, shift the AN/GRM-50 frequency setting in (3) above 50 kHz towards the end that falls off and repeat (4)

through (16) above until proper results are obtained.

(18) Disconnect the test setup.

e. 17.847 MHz Trap Circuit Adjustment. Perform the procedures outlined in *b* above, then proceed as follows:

(1) With the AN/USM-207, set the AN/GRM-50 for a cw output of 17.847 MHz \pm 1 kHz at 200 mv rms, and connect this output through a 0.01 microfarad capacitor in series with a 3.3K ohm resistor to terminal A1E20.

(2) On the test set, set the MHz FREQ 10 MHz control to 0, the MHz FREQ 1 MHz control to 5, and the MHz FREQ .1 MHz control to 0.

(3) On tray A3, set the three FREQ SELECT controls to 0.

(4) Connect a short jumper between terminals A1E18 and A1E19.

(5) Connect the AN/USM-306 to terminal A1E20 and tune it to 17.847 MHz.

(6) Without disturbing the tuning of the AN/USM-306, disconnect it from terminal A1E20 and reconnect it to terminal A3E14.

(7) Adjust inductor A1L5 for a null on the AN/USM-306.

(8) Disconnect the test setup.

f. 27.847 MHz Trap Circuit Adjustment. Perform the procedures outlined in *b* above, then proceed as follows:

(1) With the AN/USM-207, set the AN/GRM-50 for a cw output of 27.847 MHz \pm 1 kHz at 200 mv rms.

(2) Connect the AN/GRM-50 output through a 0.01 microfarad capacitor in series with a 3.3K ohm resistor to terminal A1E15.

(3) Connect a short jumper between terminals A1E13 and A1E14.

(4) Connect the AN/USM-306 to terminal A1E15 and tune it to 24.847 MHz.

(5) Without disturbing the tuning of the AN/USM-306, disconnect it from terminal A1E15 and reconnect it to terminal A2E14.

(6) Adjust inductor A1L4 for a null on the AN/USM-306.

(7) Disconnect the test setup.

g. 10.747 MHz, 17.847 MHz, 27.847 MHz, Agc and Output Circuit Adjustments. Perform the adjustments outlined in *c* through *f* above, then set the MHz FREQ 10 MHz control to 0, the MHz FREQ 1 MHz control to 6, and the MHz FREQ .1 MHz control to 5.

(1) On tray A3; set the FREQ SELECT 10 kHz control to 0, the FREQ SELECT 1 kHz to 0, and the FREQ SELECT 100 kHz to 5.

(2) Connect a jumper between terminal A3E9 and ground (fig. 3-13).

(3) With the AN/USM-207, and the AN/GRC-50, tune the AN/USM-306 to 27.847 MHz \pm 3 kHz.

(4) Connect the AN/USM-306 to terminal A3E2 and do not disturb the references as set in (3) above.

(5) Tune in the following order, transformers A2T2, A2T1, A3T4, A3T3, A3T2, and A3T1 for a peak indication on the AN/USM-306.

(6) Repeat f(6) above, to compensate for interaction between the transformers.

(7) Connect the AN/URM-145 to terminal A2E14.

(8) On the test set, set the MHz FREQ 10 MHz control to 0, the MHz FREQ 1 MHz control to 5, and the MHz FREQ .1 MHz control to 5.

(9) On tray A3, set the FREQ SELECT 10 kHz control to 0, the MHz SELECT 1 kHz control to 0, and the FREQ SELECT 100 kHz control to 5.

(10) Remove the jumper for terminal A3E9.

(11) Adjust potentiometer A2R13 for a 110 mv rms indication on the AN/URM-145 connected to terminal A2E14.

(12) On the test set, set the MHz FREQ 10 MHz control to 0, the MHz FREQ 1 MHz control to 6 and the MHz FREQ .1 MHz control to 5.

(13) Adjust inductor A2L3 for a 142 mv rms indication on the AN/URM-145.

(14) Repeat (8) through (13) above until correct indications are obtained.

(15) Connect the AN/USM-306 to terminal A2E14, in place of the AN/URM-145.

(16) On the test set, set the MHz FREQ 10 MHz control to 0, the MHz FREQ 1 MHz control to 5, and the MHz FREQ .1 MHz control to 8.

(17) On tray A3, set the FREQ SELECT 10 kHz control to 0, the FREQ SELECT 1 kHz control to 0, and the FREQ SELECT 100 kHz to 8.

(18) Adjust the AN/USM-306 for 23.2 MHz. Set up the 23.2 MHz tone for a 0 db reference level.

(19) Unsolder the wire from terminal A2E2. Connect the TS-352B/U in series with unsoldered wire and terminal A2E2. Set the TS-352B/U to measure a current between 0 and 1 ma.

(20) Tune capacitor A3C14 for minimum spurious signal tones \pm 1 MHz from 23.2 MHz reference level.

(21) Retune transformers A3T4 and A3T3 for a minimum indication on the TS-352B/U.

(22) Repeat (20) and (21) above until the spurious signals are 50 db below the 23.2 MHz tone on the AN/USM-306.

(23) On the test set, set the MHz FREQ 10 MHz control to 0, the MHz FREQ 1 MHz control to 6, and the MHz FREQ .1 MHz control to 8.

(24) On tray A3; set the FREQ SELECT 10 kHz control to 0, the FREQ SELECT 1 kHz control to 0, and the FREQ SELECT 100 kHz control to 8.

(25) With the AN/GRM-50 and the AN/USM-207 tune the AN/USM-306 to 20 MHz.

(26) Connect the AN/USM-306 to terminal A3E2.

(27) Tune capacitor A3C5 for a minimum indication of 20 MHz on the AN/USM-306.

(28) Tune transformers A3T1 and A3T2 for a minimum indication on the multimeter connected to terminal A2E2.

(29) Disconnect the test setup.

(30) Resolder the wire to terminal A2E2.

3-25. 10 and 1 kHz Synthesizer Module 1A4 Adjustment Procedures

For test point and parts located, see figures 3-16, 3-22, and 3-23. Schematic diagram is shown in figure 4-37 for the RT-662/GRC, and figure 4-39 for the RT-834/GRC.

a. Test Equipment (1A4 Adjustment). Test equipment and materials required for 1A4 adjustment are as follows:

- (1) Voltmeter, Electronic AN/URM-145.
- (2) Generator, Signal AN/GRM-50.
- (3) Radio Test Set AN/USM-306.
- (4) Electronic Counter Digital Readout AN/USM-207.
- (5) Simulator, Radio Frequency SM-442A/GRC.
- (6) Radio Set AN/GRC-106(*) modules:
 - (a) 100 kHz synthesizer module 1A2.
 - (b) Frequency standard module 1A3.
 - (c) Frequency dividers module 1A6.
 - (d) Translator module 1A8.
 - (e) MHz synthesizer module 1A9.
- (7) One 0.01 microfarad, 50 volt capacitor.
- (8) One 3.3K ohm, 1/4 watt resistor.

b. Preparation (1A4 Adjustment). Perform the following preliminary procedures:

- (1) Connect tray A3 to the test set.
- (2) Make the preliminary settings for the SM-442A/GRC with instructions given in TM 11-6625-847-12.
- (3) Plug the 10 and 1 kHz synthesizer module 1A4 to be adjusted into tray A3.
- (4) Plug into tray A3, one known good spare module of each of the following: 100 kHz synthesizer module 1A2, frequency standard module 1A3, frequency dividers module 1A6, translator module 1A8, and MHz synthesizer module 1A9.
- (5) Set the test set, SERV SEL switch to SSB/NSK.
- (6) Turn on all of the test equipment and allow 30 minutes for warmup.
- (7) Remove the dust cover from the 10 and 1 kHz synthesizer module 1A4.

c. Triple Tuned Filter Circuit Adjustment. Perform the preliminary procedures outlined in *b* above, then proceed as follows:

NOTE

For test point and component locations refer to figures 3-21, 3-22, and 3-23.

- (1) On the 10 and 1 kHz synthesizer module, connect terminals A1E15 and A1E4 to ground.
- (2) Connect the AN/URM-145 to 10 and 1 kHz synthesizer module test point A1J1.
- (3) With the AN/USM-207, set up the AN/GRM-50 for a cw output of 4.6 MHz ± 0.5 kHz at 1.0 v rms.
- (4) Connect the AN/GRM-50 output to terminal A1E12 through a 3.3K ohm resistor.
- (5) Connect a 0.01 microfarad capacitor between terminal A1E18 and ground.
- (6) Set the AN/GRM-50 for a 50 mv rms indication on the AN/URM-145.
- (7) Tune transformer A1T2 for a peak indication on the AN/URM-145.
- (8) Disconnect the 0.01 microfarad capacitor from terminal A1E18 and connect it between terminal A1E17 and ground.
- (9) Tune inductor A1L2 for a null on the AN/URM-145.
- (10) Remove the 0.01 microfarad capacitor.
- (11) Tune inductor A1L1 for a peak indication on the AN/URM-145.
- (12) To reduce interaction between the adjustments, repeat (5) through (11) above.

(13) Connect the AN/GRM-50 to terminal A1E16 and adjust it for a 50 mv rms indication on the AN/URM-145.

(14) Sweep the AN/GRM-50 output from 4.54 to 4.66 MHz. The indication on the AN/URM-145 should not vary more than ± 3 db from 50 mv rms, and should be symmetrical about the 4.6 MHz center frequency.

(15) If the variations in step (14) are greater than ± 3 db from 50 mv rms, repeat (5) through (11) above until correct responses are obtained.

(16) Disconnect the test setup.

d. 1.97 MHz, 9.07 MHz, Agc, and 7.1 MHz Circuit Adjustments. Perform the preliminary procedures outlined in *b* above, then proceed as follows: In these procedures where a difference exists between the 1A4 module from an RT-662/GRC and one from an RT-834/GRC, the value which applies to RT-834/GRC will be inclosed in parentheses.

- (1) Connect the AN/USM-306 to terminal A2E9 and tune to 1.97 MHz (1.981 MHz).
- (2) Set the tray A3 FREQ SELECT 1 kHz control to 5.
- (3) Tune transformer A1T1 for a peak indication on the AN/USM-306.
- (4) Tune the AN/USM-306 to 9.07 MHz.
- (5) Set tray A3 FREQ SELECT 10 kHz control to 5.
- (6) Tune transformer A2T1 for a peak indication on the AN/USM-306.
- (7) Set tray A3 FREQ SELECT 10 kHz control and FREQUENCY SELECT 1 kHz control to 4.
- (8) Rotate the adjustment of transformer A2T4 fully counterclockwise. Rotate potentiometer A2R17 fully counterclockwise then rotate clockwise five turns.
- (9) Connect the AN/USM-306 to terminal A2E7 and tune it to 7.1 MHz (7.089 MHz).
- (10) Alternately adjust transformers A2T2 and A2T3 for a peak output on the AN/USM-306.
- (11) Adjust transformer A2T4 for a minimum indication on the AN/USM-306.
- (12) Adjust potentiometer A2R17 for a 35 mv rms indication on the AN/USM-306.
- (13) Disconnect the test setup.

3-26. MHz Synthesizer Module 1A9 Adjustments

Test points and parts location are shown in figures 3-33 through 3-36. The schematic diagram is shown in figure 4-43.

a. Test Equipment (1A9 Adjustment). Test equipment and materials required for 1A9 adjustment are as follows:

- (1) Voltmeter, Electronic AN/URM-145.
- (2) Generator, Signal AN/GRM-50.
- (3) Electronic Counter Digital Readout AN/USM-207.
- (4) Oscilloscope AN/USM-281A.
- (5) Simulator, Radio Frequency SM-442A/GRC.
- (6) Radio Set AN/GRC-106(*) modules:
 - (a) 100 kHz synthesizer module 1A2.
 - (b) Frequency standard module 1A3.
 - (c) 10 and 1 kHz synthesizer module 1A4.
 - (d) Translator module 1A8.
 - (e) MHz synthesizer module 1A9.

b. Preparation (1A9 Adjustment). Perform the following preliminary procedures:

- (1) Connect tray A3 to the test set.
- (2) Make the preliminary settings for the SM-442A/GRC according to instructions given in TM 11-6625-847-12.
- (3) Plug the MHz synthesizer module 1A9 to be adjusted into tray A3.
- (4) Plug into tray A3, one known good spare module of each of the following: 100 kHz synthesizer module 1A2, frequency standard module 1A3, 10 and 1 kHz synthesizer module 1A4, frequency dividers module 1A6, and translator module 1A8.
- (5) Set the test set SERV SEL switch to SSB/NSK.
- (6) Turn on all of the test equipment and allow 30 minutes for warmup.
- (7) Remove the dust cover from the MHz synthesizer module 1A9 to be tested.

c. Spectrum Generator and IF Loop Circuit Adjustments. Perform the preliminary procedures outlined in *b* above, then proceed as follows:

NOTE

For component and test point location refer to figures 3-33 through 3-36.

- (1) Rotate the adjustment of transformer A1T1 fully clockwise, then rotate the adjustment of transformer A1T1 one and one-half turns counterclockwise.

- (2) Set the test SERV SEL switch to STBY.

- (3) Unsolder the lead between terminals A2E7 and A2E8. Connect terminal A2E8 to ground.

- (4) Set the test set SERV SEL switch to SSB/NSK.

- (5) Connect the AN/USM-281A high impedance probe to terminal A2E5.

- (6) Alternately adjust transformers A2T1, A2T2, and A2T3 for maximum peaks on the AN/USM-281A display. The two-tone waveform should be at least 1 v pp.

- (7) Connect the AN/USM-281A probe to terminal A2E7.

- (8) Adjust potentiometer A2R15 until a 17 volt pp sine wave appears on the AN/USM-281A display.

- (9) Leave the AN/USM-281A probe at terminal A2E7.

- (10) Rotate the test set MHz FREQ 10 MHz and MHz FREQ 1 MHz controls through their full ranges, while observing the waveform on the AN/USM-281A display. The top of the waveform remains at approximately 19.5 volts while the bottom varies between 0 and 5 volts.

- (11) If the indication in (10) above is not correct, readjust potentiometer A2R15 for the correct result.

- (12) Connect lead between A2E7 and A2E8.

- (13) Connect AN/USM-281A probe to A2E7 and note a pure dc level between 9.0 and 17.0 vdc.

- (14) Rotate test set 10 MHz, 1 MHz, and kHz controls through their full range, and observe pure dc level each time.

- (15) Disconnect the test setup.

3-27. Transmitter IF and Audio Module 1A5 Adjustments

Test points and parts location are shown in figures 3-24, 3-25, and 3-26. Schematic diagram is shown in figure 4-39.

a. Test Equipment (1A5 Adjustment). Test equipment required for 1A5 adjustment is as follows:

- (1) Voltmeter, Electronic AN/URM-145.
- (2) Electronic Voltmeter ME-30(*)/U.
- (3) Signal Generator AN/URM-127.
- (4) Simulator, Radio Frequency SM-442A/GRC.
- (5) Dummy Load DA-75/U.

b. Preparation (1A5 Adjustment). Perform the following preliminary steps:

- (1) Connect tray A2 to the test set.
- (2) Make the preliminary settings for the SM-442A/GRC according to instructions given in TM 11-6625-847-12.
- (3) Plug the transmitter IF and audio module 1A5 to be adjusted into tray A2 and remove the module dust cover.
- (4) Turn on all test equipment and allow a 30-minute warmup time.

c. IF Output Circuit Adjustment. Perform the procedures outlined in *b* above, then proceed as follows:

- (1) Set the test set SERV SEL switch to SSB/NSK.
- (2) On test set place the REC-XMIT switch to XMIT, IF OSCILLATOR select switch to position 1 & 2 and the IF output controls for IF OSCILLATORS 1 & 3 to their full counterclockwise positions. On test tray A2, set the AGC Sync switch to the ON position.
- (3) Connect AN/URM-145 to terminal A1E2 on module under test.
- (4) Using test set IF OSCILLATOR 2 output control and test set TWO TONE output control, adjust for a 1.0 mv indication on the AN/URM-145.
- (5) Connect the AN/URM-145 to tray A2 COMMON IF OUT connector.
- (6) Alternately adjust transformer A1T1 and A1T2 for a peak indication on the AN/URM-145. The indication should be greater than 30 mv rms.
- (7) Set test set REC-XMIT switch to REC.
- (8) Disconnect the test setup.

d. Vox Sensitivity Adjustment. Perform the procedures outlined in *b* above, then proceed as follows:

- (1) Set test set REC-XMIT switch to XMIT.
- (2) Set the output of AN/URM-127 for 500 Hz and connect the output to tray A2 600 ohm AUDIO IN connector.
- (3) Connect ME-30(*)/U to terminal A2E3 on module under test and adjust the output of the AN/URM-127 for a level of 7 mv rms.
- (4) Rotate module potentiometer, A2R41, maximum clockwise.
- (5) On tray A2, run a jumper from the TEST SELECTOR (HI) terminal to KEYLINE (RT) jack; set the VOICE MODES switch to VOX, and the TEST SELECTOR switch to

position 4. Connect a dc voltmeter to terminal A2E16 on module under test and note a dc level of $+27 \pm 3$ vdc.

- (6) Adjust potentiometer A2R41 counterclockwise until the dc voltmeter indication drops from +27 vdc to a level below 2.5 vdc.
 - (7) Disconnect test setup.
- e. Am Carrier Adjustment.* Perform the procedures outlined in *b* above, then proceed as follows:

- (1) Set test set SERV. SEL switch to AM and REC-XMIT switch to XMIT.
- (2) Set test set IF OSCILLATOR select switch to position 1.
- (3) On tray A2, set the TEST SELECTOR switch to position 1.
- (4) Connect AN/URM-145 to terminal A1E6 on module under test.
- (5) On test set, adjust IF OSCILLATOR 1 output control for 50 mv as measured on the AN/URM-145.
- (6) Connect AN/URM-145 to tray A2 COMMON IF OUT connector.
- (7) Adjust module potentiometer A1R14 for a 15 mv indication.
- (8) Disconnect the test setup.

3-28. Frequency Dividers Module 1A6 Adjustments

Test points and parts location are shown in figures 3-27, 3-28, and 3-29. The schematic diagram is shown in figure 4-40.

a. Test Equipment (1A6 Adjustment). Test equipment required for 1A6 adjustment is as follows:

- (1) Voltmeter, Electronic AN/URM-145.
- (2) Generator, Signal AN/GRM-50.
- (3) Radio Test Set AN/USM-306.
- (4) Electronic Counter Digital Readout AN/USM-207.
- (5) Oscilloscope AN/USM-281A.
- (6) Simulator, Radio Frequency SM-442A/GRC.
- (7) Voltmeter, Electronic ME-30(*)/U.

b. Preparation (1A6 Adjustment). Perform the following preliminary steps:

- (1) Connect tray A3 to the test set.
- (2) Make the preliminary settings for SM-442A/GRC according to instructions given in TM 11-6625-847-12.
- (3) Plug the frequency dividers module into tray A3.
- (4) Plug into tray A3, one known good spare module of each of the following: 100 kHz

synthesizer module 1A2, frequency standard module 1A3, 10 and 1 kHz synthesizer module 1A4, translator module 1A8, and MHz synthesizer module 1A9.

(5) Set the test set SERV SEL switch to SSB/NSK.

(6) Turn on all of the test equipment and allow 30 minutes for warmup.

(7) Remove the dust cover from the frequency dividers module.

(8) On the test set, set the MHz FREQ 10 MHz control to 0, and the MHz FREQ 1 MHz control to 2.

(9) On tray A3, set the FREQ SELECT 10 kHz control to 3, the FREQ SELECT 1 kHz control to 0, and the FREQ SELECT 100 kHz control to 5.

c. 100 kHz Pulse Repetition Rate Adjustment. Perform the procedures in *b* above, then proceed as follows:

(1) On the frequency dividers module, adjust potentiometer A1R5 maximum clockwise.

NOTE

For test points and components location, see figures 3-27, 3-28, and 3-29.

(2) With a high impedance probe, connect the oscilloscope to terminal A1E4.

NOTE

When properly adjusted, the pulse repetition frequency (prf) will be a pulse with a pulse repetition rate (prf) of 10 microseconds, a pulse width of approximately 1 microsecond at 50 percent amplitude, and an amplitude of 7 v pp.

(3) Rotate potentiometer A1R5 counterclockwise until the prf of the signal on the AN/USM-281A display just locks. Note location of adjustment.

(4) Counting the turns, continue to rotate potentiometer A1R5 counterclockwise until the signal on the AN/USM-281A display just unlocks at 100 kHz.

(5) Set potentiometer A1R5 at the midpoint between the points noted in (3) and (4) above.

(6) The signal now appearing on the AN/USM-281A display should have the characteristics of the pulse described in the note above.

(7) Disconnect the test setup.

d. 100 kHz Keyed Oscillator Circuit Adjustment. Perform the procedures outlined in *b* above, then proceed as follows:

(1) With the AN/GRM-50 and the AN/USM-207, tune the AN/USM-306 to 15.700 MHz and connect it to terminal A1E6.

(2) Tune transformer A1T2 for a peak indication on the AN/USM-306; peak indication should be greater than 15 mv rms.

(3) With the AN/USM-50 and the AN/USM-207, tune the AN/USM-306 to 15.300 MHz.

(4) Reconnect the AN/USM-306 to terminal A1E6; the indication will be greater than 10 mv rms.

(5) With the AN/USM-50 and the AN/USM-207, tune the AN/USM-306 to 16.200 MHz; the indication should be greater than 10 mv rms, and equal to the reading taken in (3) and (4) above.

(6) If the indications at 15.300 MHz and 16.200 MHz are not equal, retune transformer A1T2 to get them as close as possible.

(7) Disconnect the test setup.

e. 10 kHz Pulse Repetition Rate Adjustment. Perform the procedures outlined in *b* above, then proceed as follows:

(1) Connect the AN/USM-281A probe to terminal A2E4.

(2) Rotate potentiometer A2R12 maximum clockwise.

NOTE

Waveform should be a pulse with a prr of 100 microseconds, a pulse width of 9 microseconds at 50 percent amplitude, and an amplitude of approximately 8 v pp.

(3) Rotate potentiometer A2R12 slowly counterclockwise until the waveform on the AN/USM-281A display just locks at 10 kHz.

(4) Counting the turns, continue to rotate potentiometer A2R12 counterclockwise until the waveform on the AN/USM-281A display just unlocks.

(5) Set potentiometer A2R12 at the midpoint between settings in (3) and (4) above.

(6) The waveform on the AN/USM-281A display should have the characteristics described in the note above.

(7) Disconnect the test setup.

f. 10 kHz Keyed Oscillator Circuit Adjustment. Perform the procedures outlined in *b* above, then proceed as follows:

(1) With the AN/GRM-50 and the AN/USM-207, set the AN/USM-306 to 2.530 MHz and connect it to terminal A2E13.

(2) Tune transformer A2T3 for a peak indication on the AN/USM-306; the peak should occur at approximately 2.8 mv rms.

(3) With the AN/GRM-50 and the AN/USM-207, tune the AN/USM-306 to 2.570 MHz, and reconnect it to terminal A2E13; the indication should be greater than 1.4 mv rms.

(4) With the AN/GRM-50 and the AN/USM-207, tune the AN/USM-306 to 2.480 MHz, and reconnect it to terminal A2E13; the indication should be greater than 1.4 mv rms.

(5) If the indications received in (2) and (3) above are not equal, retune transformer A2T3 to get them as close as possible.

(6) Disconnect the test setup.

g. 1 kHz Pulse Repetition Rate Adjustment. Perform the procedures outlined in *b* above, then proceed as follows:

(1) Connect the AN/USM-281A probe to terminal A3E3.

(2) Rotate potentiometer A3R12 maximum clockwise.

NOTE

Waveform should be a pulse with a prr of 1 millisecond, a pulse width of 5 ± 2 microseconds, and an amplitude of approximately 1.2 v pp.

(3) Rotate potentiometer A3R12 counterclockwise until the waveform on the AN/USM-281A display just locks at 1 kHz, note position of adjustment.

(4) Counting the turns, continue to rotate potentiometer A3R12 counterclockwise until the waveform on the AN/USM-281A display just unlocks.

(5) Set potentiometer A3R12 at the midpoint between the points observed in (3) and (4) above.

(6) The waveform now appearing in the AN/USM-281A display should have the characteristics of the pulse described in the note above.

(7) Disconnect the test setup.

h. 1.75 MHz Output Circuit Adjustment. Perform the procedures outlined in *b* above, then proceed as follows:

(1) Connect the ME-30(*)/U to tray A3, 1.75 MHz.

(2) Alternately tune transformers A2T1 and A2T2 for a peak indication on the ME-30(*)/U.

(3) With the AN/GRM-50 and the AN/USM-207, adjust the AN/USM-306 for a frequency of 1.8 ± 2 kHz and connect it to terminal A2E11. Peak the AN/USM-306 at 1.8 MHz.

(4) Adjust capacitor A2C18 for a null on the AN/USM-306.

(5) Adjust capacitor A2C16 for a 50 ± 2 mv rms output as indicated by the ME-30(*)/U.

(6) Repeat (2) through (5) above until no deviation is noticeable.

(7) Disconnect the test setup.

i. Frequency Vernier Circuit Adjustment. Perform the procedures outlined in *b* above, then proceed as follows:

CAUTION

Do not short terminal A2E5 to ground when performing (1) below.

(1) Connect a jumper wire between terminals A2E1 and A2E6.

(2) Connect the ME-30(*)/U INPUT terminals between A2E13 and chassis ground.

(3) Connect the AN/USM-207 to the ME-30(*)/U output terminals.

NOTE

When the AN/USM-207 and ME-30(*)/U are connected as directed in *b* and *c* above, the ME-30(*)/U circuits amplify the signal to a level sufficient to drive the AN/USM-207.

(4) On tray A3, set the FREQ DIVIDER FREQ SHIFT control to + Δ F.

(5) Adjust inductor A2L2 for an indication of approximately 2.530590 MHz on the AN/USM-207.

(6) On tray A3, set the FREQ DIVIDER FREQ SHIFT control to 0.

(7) Adjust potentiometer A2R49 for an indication of 2.530000 MHz ± 20 Hz on the AN/USM-207.

(8) On tray A3, set the FREQ DIVIDER FREQ SHIFT control to $-\Delta$ F.

(9) The indication of the AN/USM-207 should be approximately 2.529410 MHz.

(10) If the change between 0 and + Δ F is not equal to the change between 0 and - Δ F, repeat (4) through (9) above, increasing or decreasing the frequency setting in (5) above as required to obtain the correct results. The change from 2.530000 MHz in each direction should be equal and between 510 and 680 Hz.

(11) Disconnect the test setup.

3-29. Receiver IF Module 1A7 Adjustments

Test points and parts location are shown in figures 3-30, 3-31, and 3-32. Schematic diagram is shown in figure 4-41.

a. Test Equipment (1A7 Adjustment). Test equipment and materials required for 1A7 adjustment are as follows:

- (1) Voltmeter, Electronic AN/URM-145.
- (2) Signal Generator AN/GRM-50.
- (3) Radio Test Set AN/USM-306.
- (4) Multimeter, ME-26(*)/U.
- (5) Electronic Counter Digital Readout AN/USM-207.
- (6) Oscilloscope AN/USM-281A.
- (7) Simulator, Radio Frequency SM-442A/GRC.
- (8) Transmitter IF and audio module 1A5.
- (9) One 50 ohm, 1/2 watt resistor.

b. Preparation (1A7 Adjustment). Perform the following preliminary steps:

- (1) Connect tray A2 to the test set.
- (2) Make the preliminary settings for the SM-442A/GRC, according to instructions given in TM 11-6625-847-12.
- (3) Plug the receiver IF module to be adjusted into tray A2.
- (4) Remove the dust cover from the receiver IF module to be adjusted.
- (5) Set the test set SERV SEL switch to SSB/NSK.
- (6) Turn on all of the test equipment and allow 30 minutes for warmup.

(7) Set the test set MHz FREQ 10 MHz control to 0, and the MHz FREQ 1 MHz control to 2.

(8) Set the test set IF OSCILLATOR select switch to 1.

(9) Use the AN/URM-145 to set the test set IF OSCILLATOR 1.75 MHz, 1.7515 MHz, and the 1.7525 MHz outputs at 200 mv rms.

c. Balanced Modulator Circuit Adjustments. Perform the procedures outlined in *b* above, then proceed as follows:

(1) On test set, set IF OSCILLATOR select switch to position 1 and REC-XMIT switch to XMIT.

(2) Connect AN/URM-145 to terminal A4E1 on module under test and adjust test set IF OSCILLATOR 1 output control for a 50 mv indication as measured on the AN/URM-145.

(3) Connect AN/URM-145 to module under test at terminal A4J2.

(4) Adjust module potentiometer A4R11 for a 1.0 mv indication.

(5) Set output of AN/URM-127 for 1000 Hz, and connect to tray A2 COMMON AUDIO IN 600 ohm connector.

(6) Connect ME-30(*)/U to terminal A4E11 on module under test and set the output of AN/URM-127 for a level of 8 ± 2 mv rms.

(7) Disconnect AN/URM-145 and ME-30(*)/U.

(8) Connect AN/URM-145 to tray A2 IF AMP OUT connector.

(9) On the receiver IF module, adjust transformer A4T2 maximum clockwise.

(10) Adjust transformer A4T1 for a maximum indication on the AN/URM-145.

(11) Adjust A4R11 for a 10 mv rms indication on the AN/URM-145.

(12) Connect the AN/USM-306 input to tray A2 IF AMP OUTPUT connector.

(13) Adjust the AN/USM-306 for best presentation of the carrier and USB tone.

(14) Alternately adjust capacitor A4C7 and potentiometer A4R4 for minimum carrier. The carrier should be at least 50 db below the USB tone.

(15) Note the indication on the AN/URM-145. If the indication has dropped below 10 mv rms, repeat (6) through (12) above until the proper indication is obtained in (14) above and the AN/URM-145 indication remains at 10 mv rms.

d. IF Amplifier and IF Agc Circuit Adjustment. Perform the procedures outlined in *b* above, then proceed as follows:

(1) Set the test set IF OSCILLATOR select switch to position 1 & 3 and REC-XMIT switch to REC.

(2) On tray A2, set the RCVR IF RF-AGC switch to OFF.

(3) On tray A2 set AGC SYNC switch to the ON position.

(4) Connect the AN/URM-145 to terminal A4E5. Adjust the test set IF OSCILLATOR 3 output control and test set TWO TONE output control for a 1.0 mv rms indication on the AN/URM-145.

(5) Connect the AN/URM-145 to tray A2 COMMON IF OUT connector.

(6) Adjust transformer A1T2 fully clockwise.

(7) Alternately adjust transformers A1T1 and A1T3 for a peak indication on the AN/URM-145.

(8) On tray A2, set the RCVR IF RF-AGC switch to ON.

(9) Set the potentiometer A2R12 maximum clockwise and potentiometer A2R14 maximum counterclockwise. Readjust IF OSCILLATOR 3 for 1.0 mv rms at A4E5.

(10) Adjust transformers A2T1 and A2T2 for a minimum indication on the AN/URM-145.

(11) Detune transformer A2T1 and A2T2 approximately equally until the AN/URM-145 indicates 24 mv rms. (Before making final adjustments, determine that the level at A4E5 is still 1 mv rms.)

(12) Decrease the test set IF OSCILLATOR 1.7525 MHz level control until the AN/URM-145 indication at terminal A4E5 is 0.7 mv rms.

(13) Reconnect the AN/URM-145 to tray A2 COMMON IF OUT connector and note a minimum indication of 20 mv rms.

(14) If 20 mv rms is not indicated in (13) above, repeat (10) and (11) for a level of 26 mv rms.

(15) Disconnect the test setup.

e. Audio Output Circuit Adjustment. Perform the procedures outlined in *b* above, then proceed as follows:

(1) Set the test set IF OSCILLATOR select switch to position 1 & 3 and REC-XMIT switch to REC. On tray A2 set the AGC SYNC switch to ON.

(2) Connect the AN/URM-145 to module under test at terminal A4E5 and adjust test set IF OSCILLATOR 3 output control and test set TWO TONE output control for a 1.0 mv rms level.

(3) Connect the AN/URM-145 to terminal A4E1 and adjust test set IF OSCILLATOR 1 output control for a level of 50 mv rms.

(4) On tray A2 set the REC IF TEST selector switch to position 4.

(5) Connect ME-30(*)/U to tray A2 REC IF TEST SELECTOR terminals HI-LO, (LO is ground).

(6) Adjust module potentiometer A3R11 for 750 ± 150 mv rms as measured on the ME-30(*)/U.

(7) Disconnect the test setup.

f. Bfo Circuit Adjustments. Perform the procedures outlined in *b* above, then proceed as follows:

(1) On test set set SERV. SEL switch to CW, REC-XMIT switch to REC, and IF OSCILLATOR select switch to position 1 & 2.

CAUTION

To avoid damage to the -30 vdc power source, do not ground tray A2 RCVR IF TEST SELECTOR LO connector when the RCVR IF TEST SELECTOR switch is set to 1.

(2) On tray A2 set the REC IF TEST SELECTOR switch to position 3 and the AGC SYNC switch to ON.

(3) Connect AN/URM-145 to module under test at terminal A4E5 and adjust the test set IF OSCILLATOR 2 and the test set TWO TONE output controls for a level of 1.0 mv rms as measured on the AN/URM-145.

(4) Connect the AN/USM-207 to module under test terminal A2E3.

(5) On tray A2 rotate BFO TONE control maximum clockwise.

(6) Adjust A3L3 for $4,500 \pm 1000$ Hz, as monitored by the AN/USM-207.

(7) On tray A2 rotate BFO TONE control maximum counterclockwise.

(8) Adjust Module potentiometer A3R4 for $4,500 \pm 1000$ Hz.

NOTE

It may be necessary to readjust inductor A3L3 and potentiometer A3R4 due to interaction between both adjustments. Repeat (5) through (8) above until the $4,500 \pm 1000$ Hz requirements are met.

(9) Adjust tray A2 BFO tone control for a frequency of 1,500 Hz as monitored on the AN/USM-207. Turn RF AGC switch to ON.

(10) Connect AN/URM-145 to module terminal A2E3 and adjust transformer A3T1 for a peak as monitored on the AN/URM-145. The indication should be 750 ± 50 mv rms. Disconnect the test setup.

g. Rf Age Circuit Adjustment. Perform the procedures outlined in *b* above.

(1) Perform the IF amplifier and IF agc circuit adjustment procedures outlined in *b* above.

(2) On test set set SERV SEL switch to SSB-NSK, REC-XMIT switch to REC, and IF OSCILLATOR select switch to position 1 & 3.

On tray A2 set AGC SYNC switch to ON. Insure that RF GAIN control is maximum clockwise.

(3) Connect AN/URM-145 to test set TWO TONE OUT connector and adjust test set IF OSCILLATOR 3 and TWO TONE output controls for a level of 50 mv rms.

(4) On tray A2 set RCVR IF AGC switch to ON.

(5) Connect ME-26(*)/U to tray A2 RF AGC output terminals.

(6) Adjust module potentiometer A2R14 for -24 vdc as monitored on the ME-26(*)/U.

(7) Set the test set TWO TONE selector switch to position 1 and note the indication on the ME-26(*)/U drops to 0 (+0.3, -0) vdc.

(8) Disconnect the test setup.

3-30. Receiver Audio Module 1A10 Adjustments

Test points and parts location are shown in figures 3-37, 3-38, and 3-39. The schematic diagram is shown in figure 4-44.

a. Test Equipment (1A10 Adjustment). Test equipment and materials required are as follows:

- (1) Voltmeter, Electronic AN/URM-145.
- (2) Signal Generator AN/URM-127.
- (3) Simulator, Radio Frequency SM-442A/GRC.
- (4) Voltmeter, Electronic ME-30(*)/U.
- (5) 600 ohm, 1/4 watt resistor.

b. Preparation (1A10 Adjustment). Perform the following preliminary steps:

- (1) Connect tray A2 to the test set.
- (2) Make the preliminary settings for the SM-442A/GRC according to instructions given in TM 11-6625-847-12.
- (3) Plug the receiver audio module 1A10 to be adjusted into tray A2.
- (4) Set the test set SERV SEL switch to SSB/NSK.
- (5) Turn on all of the test equipment and allow 30 minutes for warmup.
- (6) Remove the dust cover from the receiver audio module.
- (7) On tray A2, connect a 600 ohm resistor between RCVR AUDIO OUTPUTS 10 MW and ground.

c. Squelch Level Adjustment. Perform the procedures outlined in *b* above, then proceed as follows:

- (1) Set the AN/URM-127 for an output of 1,000 Hz to 0 volt rms and connect it to the tray A2 AUDIO 600 Ω IN connector.
- (2) Set tray A2 RCVR AUDIO SQUELCH switch to OFF, SQUELCH SYNCH switch to ON, and the RCVR AUDIO GAIN control maximum clockwise.
- (3) Connect ME-30(*)/U to tray A2 RCVR AUDIO OUTPUTS 10 mw connector.
- (4) Adjust the AN/USM-127 for an indication of 2.45 v rms on the ME-30(*)/U.
- (5) Set the tray A2 RCVR AUDIO SQUELCH switch to ON.

NOTE

For test point and component location refer to figures 3-37, 3-38, and 3-39.

- (6) On the receiver audio module, adjust SQUELCH LEVEL potentiometer A2R2 so that the AN/URM-145 indication is 245 mv rms.
- (7) Disconnect the test setup.

d. Squelch Sensitivity Adjustment. Perform the procedures outlined in *b* above, then proceed as follows:

- (1) Set the AN/URM-127 for an output of 500 Hz at 35 mv rms connect it to the tray A2, AUDIO 600 OHM IN connector. Turn SQUELCH SYNC to ON.
- (2) Connect the ME-30(*)/U to the tray A2 POWER AUDIO OUTPUTS 10 MW connector.
- (3) Set tray A2 RCVR AUDIO SQUELCH switch to ON, SQUELCH SYNC switch to ON, and the RCVR AUDIO GAIN control maximum clockwise.
- (4) Rotate receiver audio module SQUELCH SENS potentiometer A2R10 fully counterclockwise.
- (5) Set the ME-30(*)/U to its most sensitive scale.
- (6) Rotate receiver audio module SQUELCH SENS potentiometer A2R10 slowly clockwise until the sudden increase is noted on the ME-30(*)/U.
- (7) Switch the tray A2 RCVR AUDIO SQUELCH switch to ON and OFF, while observing the ME-30(*)/U indications. Adjust receiver audio module SQUELCH SENS potentiometer A2R10 until the ME-30(*)/U indications for the squelch on the squelch off condition differ by 0 db.
- (8) Disconnect the test setup.

3-31. Dc-to-Dc Converter and Regulator Module 1A11 Adjustment Procedures

For test point and parts location, see figures 3-40 through 3-43. Schematic diagram of module 1A11 is shown in figure 4-45.

a. Test Equipment for 1A11 Adjustment.

Test equipment required follows:

(1) Simulator, Radio Frequency SM-442A/GRC.

(2) Multimeter ME-26(*)/U.

b. Preparation for 1A11 Adjustment.

(1) Connect tray A1 to the test set.

(2) Make preliminary settings for SM-442A/GRC with instructions given in TM 11-6625-847-12.

(3) Plug the dc to dc converter and regulator module 1A11 to be adjusted into tray A1.

(4) Set the test set SERV SEL switch to SSB/NSK.

(5) Turn on all test equipment and allow 30 minutes for warmup.

(6) Remove dust cover from 1A11 module.

c. +20 vdc Regulated Adjustment. Perform the procedures outlined in b above, then proceed as follows:

(1) Connect the ME-26(*)/U positive lead to 1A11A1J1 (+20 VDC REG) and the negative lead to 1A11A1J2 (GRC).

(2) Observe voltage indication of ME-26(*)/U meter. Voltage should be between 19.3 and 19.7 vdc.

(3) If voltage reading is not within limits, adjust potentiometer 1A11A1R8 until voltage reads 19.5 vdc.

(4) Disconnect test setup.

3-32. Frequency Standard Module 1A3 Adjustment Procedure

Test points and parts location are shown in figures 3-14 through 3-20. The schematic diagram is shown in figure 4-36.

a. Test Equipment (1A3 Adjustment). Test equipment and materials required are as follows:

(1) Voltmeter, Electronic AN/URM-145.

(2) Signal Generator AN/GRM-50.

(3) Electronic Counter Digital Readout AN/USM-207.

(4) Oscilloscope AN/USM-281A.

(5) Simulator, Radio Frequency SM-442A/GRC.

(6) Radio Set AN/GRC-106(*) modules:

(a) 100 kHz synthesizer module 1A2.

(b) 10 and 1 kHz synthesizer module 1A4.

(c) Frequency dividers module 1A6.

(d) Transistor module 1A8.

(e) MHz synthesizer module 1A9.

(7) Connect Adapter UG-274B/U.

(8) One 50 ohm, 1/2 watt resistor.

b. Preparation (1A3 Adjustment). Perform the following preliminary steps:

(1) Remove the dust cover from repaired frequency standard module 1A3.

(2) Connect tray A3 to the test set.

(3) Make the preliminary settings for the SM-442A/GRC according to the instructions given in TM 11-6625-847-12.

(4) Plug frequency standard module 1A3 to be adjusted into tray A3.

(5) Plug into tray A3, one known good spare module of each of the following: 100 kHz synthesizer module 1A2, 10 and 1 kHz synthesizer module 1A4, frequency dividers module 1A4, frequency dividers module 1A6, translator module 1A8, and MHz synthesizer module 1A9.

(6) Check to see that tray A3 POWER VAR-FIXED switch is set to FIXED.

(7) Turn on all test equipment.

(8) Set the test set SERV SEL switch to SSB/NSK and allow 30 minutes for the equipment to warmup.

(9) Set the INT-EXT switch on the repaired frequency standard module 1A3 to EXT.

(10) With the AN/USM-207, set the output from the AN/GRC-50 for a cw output of 5.000000 MHz at a level of 50 mv rms and connect it to the 5 MHz EXT-INT connector on the FREQ STANDARD section of tray A3.

NOTE

For location of test points referred to in the steps below, refer to figures 3-14 through 3-17.

(11) Connect the AN/URM-145 to test point A3J2 and adjust transformer A3T3 for a peak indication on the rf millivoltmeter.

NOTE

No adjustment is required for transformer A3T2.

c. 1 MHz Circuit Adjustment. Perform the procedures outlined in b above, then proceed as follows:

(1) Connect the output from the AN/GRM-50 to a tee connector.

(2) Connect one output from the tee connector through a 50 ohm resistor to test point A2J2 on the top of frequency standard module 1A3.

(3) Connect the other output from the tee connector to the AN/USM-207.

(4) Connect the AN/URM-145 to terminal A2E9.

(5) Set the output meter level of the AN/GRM-50 to 500 mv rms.

(6) Adjust the frequency output from the AN/GRM-50 for a 3.950 MHz \pm 1 kHz indication on the AN/USM-207.

(7) Tune transformer A2T2 for maximum indication on the AN/URM-145.

(8) Disconnect the AN/GRM-50 and the AN/URM-145 from the frequency standard module.

(9) Leave the AN/GRM-50 output connected to the tee connector and connect one output from the tee connector to the AN/USM-281A vertical input.

NOTE

Use the vertical input section of the AN/USM-281A to amplify the output of the AN/GRM-50 to supply sufficient input voltage to the AN/USM-207 during the following steps.

(10) Connect the AN/USM-207 to the AN/USM-281A vertical signal output connector.

(11) Connect the second output from the tee connector connected to the AN/GRM-50 to the 5 MHz EXT-INT connector on the FREQUENCY STANDARD section of tray A3.

(12) Connect the AN/URM-145 to test point A2J2 on the top of frequency standard module 1A3.

(13) Set the output level from the AN/GRM-50 to 25 mv rms. Set the output frequency for a 5.000 MHz \pm 1 kHz indication on the AN/USM-207.

(14) Adjust transformer A2T3 for a maximum indication on the AN/URM-145.

(15) Disconnect the AN/URM-145 from test point A2J2.

(16) Connect the AN/USM-281 horizontal input to the frequency standard module test point A2J2.

(17) Adjust the output of the AN/GRM-50 to 75 mv rms.

(18) Slowly decrease the frequency of the AN/GRM-50 output below 5 MHz until the 15:1 lissajous pattern on the AN/USM-281A becomes unlocked (no pattern).

(19) Slowly increase the frequency of the AN/GRM-50 output back towards 5 MHz. The

lissajous pattern on the AN/USM-281A should become locked before the indication on the AN/USM-207 reaches 4.940 MHz.

(20) Slowly increase the frequency of the AN/GRM-50 output about 5 MHz until the 5:1 lissajous pattern on the AN/USM-281A becomes unlocked (no pattern).

(21) Slowly decrease the frequency of the AN/GRM-50 output back towards 5 MHz. The lissajous pattern on the AN/USM-281A should become locked before the indication on the AN/USM-207 reaches 5.060 MHz.

(22) The lissajous pattern on the AN/USM-281A should become unlocked at the same (approximate) number of kHz above and below 5 MHz. If the lissajous pattern does not lock correctly below 4.940 MHz, subtract 5 kHz from the frequency setting in (6) above, and repeat (4) through (21) above. Continue to subtract 5 kHz from the frequency setting in (6) and (13) above until a locked condition can be obtained below 4.940 MHz. If the lissajous pattern does not lock correctly above 5.060 MHz, repeat (4) through (21) above, adding 5 kHz to frequency settings in (6) and (13), until a locked condition can be obtained, which is symmetrical with the point of locking below 4.940 kHz.

d. 500 kHz Circuit Adjustments. Perform the procedures outlined in *b* and *c* above, then proceed as follows:

(1) Connect the AN/USM-281A vertical input to test point A2J1 on top of frequency standard module 1A3.

(2) Connect the AN/USM-281A horizontal input to test point A2J2 on the top of frequency standard module 1A3.

(3) Connect the AN/USM-207 to terminal A3J2.

(4) Set the AN/GRM-50 for an output level of 75 mv rms and adjust the frequency output for a 5 MHz \pm 1 kHz indication on the AN/USM-207.

(5) Tune transformer A2T1 for a locked-in phase 2:1 lissajous pattern on the AN/USM-281A. (The pattern should appear a single trace when properly adjusted.)

(6) Slowly decrease the frequency of the AN/GRM-50 output below 5 MHz until the lissajous pattern on the AN/USM-281A becomes unlocked (no pattern).

(7) Slowly increase the frequency of the AN/USM-50 output towards 5 MHz. The lissajous pattern should become locked before the AN/USM-207 indication reaches 4.960 MHz.

(8) Slowly increase the frequency of the AN/GRM-50 output above 5 MHz until the lissajous pattern on the AN/USM-281A becomes unlocked (no pattern).

(9) Slowly decrease the frequency of the AN/GRM-50 output towards 5 MHz. The lissajous pattern should become locked before the indication reaches 5.040 MHz.

(10) If the locking range of 4.960 to 5.040 MHz cannot be obtained, repeat the adjustment procedures, starting with paragraph 4-17b.

(11) Disconnect the test setup.

e. 10 MHz Circuit Adjustment. Perform the procedures outlined in *b* through *d* above, then proceed as follows:

(1) Set the frequency standard module 1A3 INT-EXT switch to INT.

(2) Connect the AN/URM-145 to test point A3J2 and note the voltage.

(3) Set the frequency standard module 1A3 INT-EXT switch A3S1 to EXT.

(4) With the AN/USM-207, set the AN/GRM-50 for an output frequency of 4.950 MHz ± 2.0 kHz.

(5) Connect the AN/GRM-50 to the 5 MHz EXT-INT connector on the FREQ STANDARD section of tray A3.

(6) Adjust the AN/GRM-50 output level to provide the same indication on the AN/URM-145 as was noted in (2) above.

(7) Connect the AN/URM-145 to terminal A3E1.

(8) Adjust inductor A3L1 for a peak indication on the AN/URM-145.

(9) With the AN/USM-207, set the output frequency of the AN/GRM-50 at 5.050 MHz ± 2.0 kHz.

(10) Adjust transformer A3T1 for a peak indication on the AN/URM-145.

(11) Set the frequency standard module 1A3 INT-EXT switch A3S1 to INT; the AN/URM-145 should indicate 50 ± 5 mv rms.

(12) If the level is out of tolerance, increase or decrease the frequency separation in (4) and (9) above. (Increasing the frequency separation reduces the output level. Decreasing the frequency separation increases the output level.) Repeat (1) through (11) until the level in (11) is within tolerance.

(13) Disconnect the test setup.

3-33. 100 Hz Synthesizer Module 1A1A2A8 (RT-834/GRC) Adjustment Procedures

Test points and parts location are shown in figures 2-30, 3-6, 3-7, and 3-8.

a. Test Equipment (1A1A2A8 Adjustment). Test equipment and materials required for 1A1A2A8 adjustment are as follows:

(1) Oscilloscope AN/USM-281A.

(2) Power Supply PP-4763(*)/GRC.

(3) RT-834/GRC chassis containing modules which have passed their respective proof of performance tests and the 1A1A2A8 module to be adjusted.

b. Preparation (1A1A2A8 Adjustment). Perform the following preliminary steps:

(1) Remove the RT-834/GRC chassis from the case using the procedures of paragraph 2-17a.

(2) Remove module 1A1A2A8 in accordance with paragraph 2-18a.

(3) Remove the four screws securing the A2 circuit board to the module cover and fold out circuit board.

(4) Reconnect the five connectors to module.

(5) Connect the PP-4763(*)/GRC to the POWER connector on front panel.

(6) Set PP-4763(*)/GRC for 27.5 ± 0.5 volts dc.

c. 100 Hz Synthesizer Output Frequency Adjustment. Perform the procedures given in *b* above, then proceed as follows:

(1) Set the RT-834/GRC SERVICE SELECTOR switch to CW.

(2) Connect the AN/USM-281A to terminal 1A1A2A8A1E2 (fig. 3-7). Set the sweep rate on the AN/USM-281A to 0.2 msec per cm.

(3) Set the 100 Hz frequency selector switch to 0.

(4) Turn potentiometer 1A1A2A8A2R8 (fig. 3-8) clockwise 12 turns.

(5) Adjust potentiometer 1A1A2A8A2R8 until the bottom half of the squarewave on the AN/USM-281A is 600 μ sec long (3 cm). The top half of the squarewave should now be 400 μ sec long.

(6) Disconnect test setup.

(7) Disconnect the five connectors from the 1A1A2A8 module.

(8) Fold the A2 board back in the cover and secure with the four screws.

(9) Replace module 1A1A2A8 in accordance with paragraph 2-18b.

(10) Replace RT-834/GRC chassis in case using procedures of paragraph 2-17a.

3-34. Voltage Regulator Assembly 1A1A2A9 (RT-834/GRC) Adjustment Procedures

Test points and parts location are shown in figures 2-30 and 3-26.

a. Test Equipment (1A1A2A9 Adjustment). Test equipment and materials required for 1A1A2A9 adjustment are as follows:

- (1) Multimeter ME-26(*)/U
- (2) Power Supply PP-4763(*)/GRC.
- (3) RT-834/GRC chassis containing modules which have passed their respective proof of performance tests and the 1A1A2A9 module to be adjusted.

b. Preparation (1A1A2A9 Adjustment). Perform the following preliminary steps:

(1) Remove the RT-834/GRC chassis from the case using the procedures of paragraph 2-17a.

(2) Connect the PP-4763(*)/GRC to the POWER connector on the front panel.

(3) Set PP-4763(*)/GRC output for 27 \pm 1 volts dc.

c. Voltage Regulator Assembly Output Adjustment. Perform the procedures given in *b* above, then proceed as follows:

(1) Place RT-834/GRC SERVICE SELECTOR switch to SSB/NSK.

(2) Connect ME-26(*)/U to terminal 1A1A2A9E1.

(3) Adjust potentiometer 1A1A2A9R6 for a reading of 5.0 \pm 0.1 volts dc on ME-26(*)/U.

(4) Disconnect test setup.

(5) Replace RT-834/GRC chassis in case using procedures of paragraph 2-17a.

3-35. Discriminator Assembly 2A4 Adjustment Procedures

Test points and parts location are shown in figures 3-76, 3-77, and 3-78. The schematic diagram is shown in figure 4-52.

a. Test Equipment (2A4 Adjustment). Test equipment and materials required for 2A4 adjustments are as follows:

(1) Multimeter ME-26(*)/U.

(2) Dummy Load DA-75/U.

(3) Receiver-Transmitter, Radio RT-662/GRC or RT-834/GRC (one that is in good working order to be used as a single generator).

(4) Amplifier, Radio Frequency AM-3349/GRC-106 (one that is in good working order to be used as an rf amplifier for the rf signal generator).

b. Preparation (2A4 Adjustment). Perform the following preliminary steps:

(1) Interconnect the AM-3349/GRC, and the RT-662/GRC or RT-834/GRC RF DRIVE connectors, and CONTROL and PA CONTROL connectors.

(2) Set the output of the dc power source at 27 volts dc and connect it to the RT-662/GRC or RT-834/GRC POWER connector and the AM-3349/GRC-106 PRIM. POWER connector.

(3) Remove ant. coupler 2A3 from amplifier AM-3349/GRC-106 and disconnect coaxial cable at the discriminator 2A4 within the AM-3349/GRC-106.

(4) Connect tray A5 to test set and install the 2A4 module under test on tray A5.

(5) Connect cable W14 from tray A5 discriminator RF IN connector to amplifier AM-3349/GRC-106 at discriminator 2A4, J1 input cable.

(6) Using cable W13 connect dummy load DA-75/U to the discriminator under test at J2.

(7) Turn on all power and allow a 30 minute warmup time.

(8) Connect ME-26(*)/U to tray A5 discriminator HI-LO terminals.

(9) On tray A5 set the DISCRIMINATOR TEST selector switch at position 2.

c. Discriminator Balance Adjustment. Perform the procedures given in *b* above, then proceed as follows:

(1) Set the RT-662/GRC or RT-834/GRC SERVICE SELECTOR switch to AM, and the MHz and kHz controls at 05000.

(2) Perform the following procedures at the AM-3349/GRC-106; set the PRIM PWR switch to ON; TEST METER switch to PRIM PWR position and wait approximately 60 seconds.

(3) After time-in (60 seconds) set the AM-3349/GRC-106 HIGH VOLTAGE RESET switch to TUNE.

(4) Adjust the ANT TUNE and ANT LOAD controls for center scale indications on the ANT TUNE and ANT LOAD meters.

(5) Adjust capacitor A2C1 on the module under test for a 0.0 vdc indication on the ME-26(*)/U.

(6) Disconnect the test setup.

Section IV. REPAIRS AND REPLACEMENT

CAUTION

To avoid damage to the equipment maintenance personnel should be familiar with the parts replacement technique described in paragraph 2-16a through *h*.

3-36. Receiver-Transmitter RT-834/GRC and RT-662/GRC Repair and Replacement

a. Chassis and Panel Assembly 1A1. The procedure for the removal of the chassis from the case and removal and replacement procedures for all modules, with exception of rf amplifier 1A12 (*b* below), are described in paragraph 2-17a through *g*. All front panel and chassis mounted parts can be removed and replaced using standard shop procedures.

b. Rf Amplifier Module 1A12 (fig. 2-26).

(1) Removal.

(*a*) With RT-834/GRC or RT-662/GRC operating set MHz control at 15 MHz and allow the tuning cycle to be completed.

(*b*) Set the SERVICE SELECTOR switch at OFF, disconnect source power, and remove the receiver-transmitter chassis from case (para 2-17a).

(*c*) Insure that rf amplifier module 1A12 is tuned to 15 MHz as indicated in the window at the top of the module.

(*d*) Loosen the four captive holddown screws that secure rf amplifier module 1A12 to the chassis.

(*e*) Raise the bail handles and lift the module straight up from the chassis.

(2) Replacement.

(*a*) Turn the MHz coupling at the bottom of the new or repaired rf amplifier module 1A12 until the number 15 appears in the window at the top of the module.

(*b*) Adjust the 100 kHz and 10 kHz controls so that the 100 kHz and 10 kHz couplers (fig. 2-25) are aligned with the respective 100 kHz and 10 kHz couplers of rf amplifier module 1A12.

(*c*) Position the 1A12 module into place and gently push down on the module. Rotate the 100 kHz and 10 kHz controls to insure that the couplers are properly engaged.

(*d*) Secure the module to the chassis using four captive holddown screws.

c. Repair and Replacement of Transformer Assembly, RF Amplifier Module 1A12 (fig. 4-29).

(1) Disassembly.**NOTE**

Do not disassemble rf amplifier module 1A12 beyond the instructions contained in this procedure.

(*a*) Remove rf amplifier module 1A12 from the chassis (*b* above).

(*b*) Loosen the four captive screws (126) that secure the dust cover (1) to the module chassis. Remove the dust cover.

(*c*) Remove the four screws (2) that secure the top turret ring (60) to the turret ring spacer posts (29).

(*d*) Remove the 25 megahertz strips (3) through (16) and (61) through (74) which are not meshed with contacts of the three stator block assemblies (27) and (32).

(*e*) Slowly rotate the bottom turret ring (100) until the contacts of the remaining three megahertz strips no longer mesh with the contacts of the three stator blocks. Remove the three remaining megahertz strips.

(2) Assembly.

(*a*) Replace megahertz strips A4 (74), A5 (16), A11 (10), A12 (9), A18 (3), A19 (61), A25 (67), and A26 (68).

(*b*) Rotate the bottom turret ring (100) until three of the replaced megahertz strips mesh with the contacts of the three stator block assemblies (27) and (32).

(*c*) Replace the remaining twenty megahertz strips.

(*d*) Replace the top turret ring (60) and secure to the turret ring spacers post (29) with four screws (2).

(*e*) Replace the dust cover (1) and secure with the four captive screws (126).

(*f*) Replace rf amplifier module 1A12 into the receiver-transmitter chassis (*b* above).

3-37. Amplifier, Radio Frequency AM-3349/GRC Repair and Replacement

a. Chassis and Panel Assembly 2A1 and 2A5. The procedures for the removal of chassis assembly 2A1, and front panel assembly 2A5 from the case and removal and replacement procedures for all assemblies with the exception of turret assembly 2A2 are described in paragraph 2-19a

through *h*. Removal and replacement of parts mounted to the front panel assembly are described in paragraph 2-20.

b. Turret Drum Assembly, Part of 2A2 (fig. 2-31).

(1) *Removal.*

(a) Set the PRIM PWR. circuit breaker at OFF and disconnect all interconnecting cables.

(b) Loosen the six front panel Allen screws and slide the chassis out from the case.

WARNING

Voltages up to 3,000 volts dc and 10,000 volt rf exist in the AM-3349/GRC-106. Always use a shorting stick to ground capacitors 2A5A2C4, 2A5A-2C5 (fig. 2-33), and pin A or B of PRIM POWER connector 2A5J7 before touching any components.

(c) Loosen the three Allen-head captive screws (turret drum screws, fig. 2-31) that secure the turret drum to the turret base. Insure that the screws are completely disengaged from the turret base (springs fully expanded).

CAUTION

Extreme care must be exercised when performing the following step to insure that the contacts are in no way damaged.

NOTE

When performing the following step, carefully mark the orientation of the frequency marking on the top of the turret drum with the OPERATING FREQUENCY arrow on the top of stator assembly 2A9 so that the turret can be replaced in the exact position to insure proper alignment of turret base locating pin with the keyway on the turret drum.

(d) Rotate the turret by hand until the contacts on the drum are free from the stator contacts on driver assembly 2A8 and stator assembly 2A9.

(e) Carefully lift the turret drum straight up and away from the chassis.

(2) *Replacement.*

CAUTION

Be extremely careful when performing the procedures given below to insure that the contacts do not become damaged. Before replacing turret drum, inspect for bent contacts.

NOTE

When replacing the turret drum, the physical orientation must be exactly the same as marked in (1)(e) above.

(a) Carefully set the new or repaired turret drum straight down onto the turret base. Note the positioning of the key pin that is mounted on the turret base.

(b) Rotate the turret by hand to insure proper meshing of the turret and stator contacts.

(c) Tighten the three original screws that secure the drum into the base.

(d) Slide the chassis back into the case tighten the front panel Allen screws, and reconnect all interconnecting cables.

c. Turret Base Assembly (fig. 2-32).

(1) *Removal.*

(a) Remove the Turret Drum Assembly by performing the procedure given in *b*(1) above.

(b) Tilt the chassis up on its side. While holding the turret base assembly with one hand, remove the four screws (fig. 2-32) that secure the turret base assembly to the chassis.

(c) Set the chassis down and lift out the turret base assembly.

(2) *Replacement.*

(a) Set the new or repaired turret base assembly in place on the chassis so that connector 2A2J1 properly mates with 2A1XA2.

(b) While holding the turret assembly, tilt the chassis up and replace the four original screws that secure the turret base assembly to the chassis.

(c) Replace the turret drum assembly by performing the procedure given in *b*(2) above.

d. Disassembly and Reassembly of Turret Assembly 2A2 (fig. 4-27).

(1) *Disassembly.*

(a) Remove turret assembly 2A2 from the chassis by performing the procedures given in *b* and *c* above.

(b) To remove power amplifier output filters (filter assembly A1 through A15 (4) through (18)), remove the five screws (1) in the turret drum cover (2), remove the cover, and relieving the tension of the mounting plate (3) over one filter assembly at a time, lift out a filter assembly.

(c) To remove the interstage transformers (transformer assembly A16 through A30 (24) through (38)), hold the turret drum upside-down, remove the 15 screws (41) in the mounting ring (3), and then remove the mounting ring (39), and lift out the transformer assemblies.

(2) Reassembly.

(a) Match the markings on the interstage transformers ((24) through (38)) with the markings on the turret drum base (19) and set all transformers in place.

(b) Set the mounting ring (39) in place, insure that all transformers are properly seated, and replace the 15 original screws (41) to secure the mounting ring.

(c) Turn the turret drum over, match the markings on the pa. output filters (4) through (18) with the markings on the mounting plate (3), and set the filters in place. Make certain that each filter is locked in place.

(d) Set the top cover (2) in place on the drum, and replace the five original screws (1) to secure the cover.

(e) Check the alignment of the turret code switches as outlined in paragraph 3-44.

3-38. Removal and Replacement of Components of Antenna Coupler Assembly 2A3

(fig. 2-36, 2-37, 4-11, 4-18, and 4-19)

CAUTION

Be extremely careful when working on antenna coupler assembly 2A3 to make certain that the glass envelope for variable vacuum capacitor C26 is not damaged.

a. Disassembly.

(1) Remove antenna coupler assembly 2A3 by performing the procedures given in paragraph 2-19c(1).

(2) Locate and remove the two recessed screws on the rear insulated bracket of variable vacuum capacitor C26. Remove the bracket.

(3) Locate and remove the one recessed screw on the front insulated bracket of capacitor C26.

(4) Hold capacitor C26 with one hand and tip the hinged top of the front insulated bracket out of the way. Carefully lift capacitor C26 out of the brackets and set it aside. Note the exact position of the nipple on the capacitor as the capacitor will be replaced later in the exact position.

(5) Remove the four panhead screws that secure the variable coil assembly to the assembly bottom plate. Remove the variable coil assembly.

(6) Remove the four flathead screws, nuts, and washers that secure the filter assembly to the assembly bottom plate.

(7) Remove the remaining eight panhead screws that secure the assembly bottom plate. Remove plate.

NOTE

Further disassembly procedures will seriously disturb lead dress. Sketch all connections before unsoldering.

(8) Unsolder all leads to the filter assembly and tag each lead. Set the filter assembly aside.

(9) Tag and unsolder all leads to capacitor coding switch S3.

(10) Note the position of the rotary section of S3, loosen the two setscrews in the shaft key, and remove the shaft key from capacitor coding switch S3.

(11) Loosen the two panhead screws and remove capacitor coding switch S3.

(12) Tag all leads so they may be pulled through the tie rod assembly and unsolder all leads to rf band switch coding switch S2.

(13) Loosen the two setscrews and remove the cam from switch S2 shaft key.

(14) Note the position of rotary section S2, loosen the two setscrews that secure the shaft key, and remove the shaft key.

(15) Loosen the two panhead screws and remove rf band switch coding switch S2.

(16) Remove the panhead screw from the center mounting plate assembly, which is located just in front of the front (hinged) insulated bracket for capacitor C26.

(17) Remove the nut and the wire lug from the bolt on the top of the center mounting plate assembly and unsolder the lead at the wire lug that is attached to the stator plates.

(18) Remove the rear retainer ring from the tie rod subassembly.

(19) Unscrew the nut at the front end of the tie rod assembly. Remove the nut and associated washers over the tie rod assembly leads.

(20) Use a long screwdriver, to remove the screw on the center mounting plate assembly which is located directly below rf band switch motor B2.

(21) Carefully slide the switch coil assembly away from the capacitor motor assembly, feeding the lead wires through the hollow tie rod subassembly toward the rear of the assembly at the same time.

b. Reassembly.

(1) On the capacitor-motor assembly, loosen the motor mounting bolts on capacitor

coding motor B1 so that the gear can be disengaged.

(2) Rotate the spur gear until capacitor C27 is at maximum capacity (sections fully meshed), as shown in A, figure 4-11.

(3) Replace capacitor coding switch S3; use the two original panhead screws. Position the switch and switch wiper as shown in B, figure 4-11.

(4) Push the spur gear toward the center mounting assembly as far as it will go. Hold the spur gear in place, and replace and secure the shaft key by tightening the two setscrews.

NOTE

To insure proper coding, note that when capacitor C27 is in the position shown in A, figure 4-11, capacitor coding switch S3 wiper arm is in the position shown in B.

(5) Engage the motor spur gear, and tighten the motor mounting bolts on capacitor coding motor B1.

(6) On the switch-coil assembly, rotate the spur gear until rf band switch S1 front wafer is in the position shown in C, figure 4-11, when viewed from the end opposite the spur gear.

(7) Replace rf band switch coding switch S2 with the use of the two original panhead screws. Position the switch and switch wiper as shown in D, figure 4-11.

(8) Carefully place the S2 shaft key on rf band switch S1A, B shaft so that the ears of the shaft key will fit into the notches of the rotary section of S2.

(9) Place the finger on the rear cam and push forward so that S1A and S1B rotors will be axially aligned with S1A4 and S1B4 stator contacts.

(10) Push the S2 shaft key in as far as possible and secure in place with the shaft key inset screws.

NOTE

To insure the proper coding, note that when rf band S1 front wafer is in the position shown in C, figure 4-11, and that rf band switch coding switch S2 wiper arm is in the position shown in D, figure 4-11.

(11) Join the switch-coil assembly to the capacitor-motor assembly as follows:

(a) Place the two assemblies close together, and in proper relation to each other. Feed the lead wires to rf band switch coding switch S2 through the hollow tie rod assembly.

(b) Puse the two assemblies together, insuring that the rf band switch motor B2 spur gear meshes properly with the rf band switch spur gear.

(c) Place the retainer ring on the rear end of the tie rod subassembly.

(d) Replace the wire lug and the nut on the bolt through the top of the center mounting plate assemblies.

(e) Replace the panhead screw which is located just in front of the front (hinged) insulated bracket for capacitor C26 on the center mounting plate assembly.

(f) Replace the screw into the hole in the center mounting plate assembly which is located directly below rf band switch motor B2. Tighten the screw.

(g) Resolder the lead to the wire lug which is attached to the stator plates of C27.

(h) Replace the washers and fasten the nut to the front end of the rod assembly.

(12) Resolder all wires to the filter assembly and position the filter assembly into place.

(13) Replace the bottom mounting plate; use the original eight panhead screws (a(7) above).

(14) Secure the filter assembly to the bottom mounting plate; use the four original flathead screws, washers, and nuts.

(15) Resolder the wire leads to rf band switch coding switch S2.

(16) Resolder the wire leads to capacitor coding switch S3.

(17) Replace the variable coil assembly, use the four panhead screws and the one flathead screw. Make certain that the L1 silver-plated contact is over and making contact with the C26-1 contact.

(18) Carefully set variable vacuum capacitor C26 in place on the insulated brackets, with the slot in the coupling vertical to the bottom mounting plate.

NOTE

The slot in the coupling should be vertical, when the shaft of capacitor C26 is rotated counterclockwise to the stop, with the capacitor placed on the brackets so that the nipple of the glass envelope formed by the vacuum seal is turned in the same position as when removed.

(19) Swing the front (hinged) insulated bracket over the top of capacitor C26 and tighten it down; use the original panhead screw.

(20) Replace and secure the rear insulated bracket on capacitor C26; use the two original panhead screws.

(21) To replace S2 cam, it will be necessary to press the cam follower toward L1. Replace the S2 cam over the S2 shaft key in a position shown in figures 4-18 and 4-19. Secure the cam in position using the cam insert screws.

(22) Replace antenna coupler assembly 2A3 on the chassis by performing the procedures given in paragraph 2-19c(2).

3-39. Removal and Replacement of Parts of Turret Base Assembly (Part of 2A2)

a. Disassembly. Refer to figure 4-27.

(1) Remove turret base assembly by performing the procedures given in paragraph 3-36d(1).

(2) Remove the four screws (103) that secure the turret base cover (42) and remove the cover.

(3) Remove the two screws (97) that secure the bracket for component board A31, coding assembly board (101), to the turret assembly base (110) and lay the component board back out of the way.

(4) Unsolder the turret motor leads (red and black) from component board A31.

(5) Remove the two screws (77) that secure the motor cover (80) to the turret motor (84) and remove the motor cover.

(6) Remove the four screws (82) that secure the turret motor (84) to the motor mount (87).

(7) Pull the turret motor leads free through the slot in the turret assembly base (110) and lift out the turret motor (84).

(8) Remove the four screws (108) that secure the motor mount (87) to the turret assembly base (110), slide the motor mount to one side to free it, and lift the motor mount free.

(9) Remove the two screws (93) that secure connector J1 (95) and lay the connector back out of the way.

(10) Remove the six screws (107) that secure the turret assembly base (110) to the ring bearing retainer (67) and then remove the turret assembly base.

(11) Remove the six screws (53) that secure the five decks of rotary switch contacts S1 through S5 rotor (57), (59), (61), (63), and (65), and remove the top three decks, including the insulator bushing (56) and insulator ring (58).

CAUTION

Extreme care must be taken when performing the procedures given in (12) below to insure that the code switches are not damaged.

(12) Loosen but do not remove the eight screws (43) that secure the switch decks, contact assemblies (46), (47), (49), and (51), and very carefully lift off the entire switch group, the cable, the connector, and the component board at once.

(13) Lift off the remaining decks of rotary contacts, S4 and S5 rotor (63) and (65).

(14) Dismantle the switch sections only as far as required. When unsoldering leads, carefully tag each to insure proper replacement.

b. Reassembly.

(1) Set the bottom two decks of rotary contacts and spacers in place on the base. Align the spacers and contact decks with the locating hole in the base.

CAUTION

Extreme care must be taken when performing the procedures given in (2) below to insure that the code switches are not damaged.

(2) Very carefully set the switch group, cable, connector, and component board in place. Tighten the eight screws (43) to secure the contact assemblies (46), (47), (49), and (51).

(3) Set the top three decks of rotary switch contacts, S1 through S5 rotor ((57), (59), and (61)), and respective spacers in their correct positions and replace the six original screws (53) to secure them.

(4) Set the turret assembly base (110) in place and replace the six screws (107) that secure it.

(5) Replace the two original screws, (93) that secure connector J1 (95).

(6) Insuring that the gears mesh properly, set the motor mount (87) in place on the turret assembly base and replace the four original screws (108) to secure it.

(7) Thread the turret motor leads through the slot in the turret assembly base, set the turret motor (84) on the motor mount (87), and replace the four original screws (82) to secure the turret motor.

(8) Replace the motor cover (80) on the turret motor and replace the two original screws (77) to secure it.

(9) Resolder motor leads to component board A31, coding assembly board (101).

(10) Set the component board bracket in place and replace the two original screws (97) to secure it.

(11) Replace the turret base cover (42) and secure with the four screws (103).

(12) Replace turret base assembly by performing the procedures given in paragraph 3-37d(2).

Section V. LUBRICATION

3-40. General

a. This section contains lubrication instructions for general support maintenance of Radio Frequency Amplifier AM-3349/GRC-106. Lubrication points and parts location information are illustrated in figures 3-50, 3-51, and 3-52. The symbol Q on illustrations indicated lubrication intervals and designates 3 months. A 3-month interval consists of 90 8-hour days. If the equipment is operated more than 8 hours per day, increase the frequency of lubrication accordingly. The contacts of all switches should be lubricated with any standard switch lubricant at 6-month intervals. This helps to insure optimum performance by keeping the contacts clean and free from corrosion. Use lubricants MIL-M-7866A (ASG), FSN-NISL-P/N 15091, or FSN-NISL-P/N 15093 for all other points.

b. Lubrication instructions for RT-834/GRC and RT-662/GRC are contained in the direct support maintenance procedures (chap. 2).

3-41. Lubrication of Amplifier, Radio Frequency AM-3349/GRC-106

a. Disassembly. To disassemble the AM-3349/GRC-106 for lubrication, proceed as follows:

(1) Remove the front panel by performing the procedures given in paragraph 2-19a(1).

(2) Remove the gear drive assembly by performing the procedures given in paragraph 2-20a(2).

(3) Remove antenna coupler assembly 2A3 by performing the procedures given in paragraph 2-19c(1).

(4) Remove the turret drum and turret base by performing the procedures given in paragraph 3-37b(1) and c(1).

(5) Remove the four screws on the perimeter of the turret base, and lift off the rotary deck cover.

(6) Reinstall the turret base on the chassis.

b. Lubrication. To clean and lubricate all required parts of the AM-3349/GRC-106, proceed as follows:

(1) *Gear drive assembly.* Locate all points to be lubricated, on figure 3-50. While rotating the gears by hand, clean all lubrication points with a brush dipped in cleaning compound. Use a clean brush to apply a light film of lubricant MIL-M-7866A (ASG) to all points.

(2) *Antenna coupler assembly 2A3.* Locate all points to be lubricated on figure 3-51. Use the coupling joints to rotate the gears and clean them with a brush dipped in cleaning compound. Use a clean brush to apply a light film of lubricant MIL-M-7866A (ASG) to all points.

(3) *Turret assembly 2A2.* Locate all points to be lubricated on figure 3-52. Rotate the gears by hand and clean them with a brush dipped in cleaning compound. Use a clean brush to apply a light film of lubricant MIL-M-7866A (ASG).

c. Reassembly. To reassemble the AM-3349/GRC-106 after lubrication, proceed as follows:

(1) Remove the turret base from the chassis and replace the rotary deck cover with the four screws.

(2) Replace the turret base by performing the procedures given in paragraph 3-37c(2).

(3) Replace the turret drum by performing the procedures given in paragraph 3-37b(2).

(4) Replace the gear drive assembly by performing the procedures given in paragraph 2-20b(1).

(5) Replace the dc-to-dc converter assembly by performing the procedures given in paragraph 2-19f(2).

(6) Replace the antenna coupler assembly by performing the procedures given in paragraph 2-19c(2).

(7) Replace the front panel by performing the procedures given in paragraph 2-19a(2).

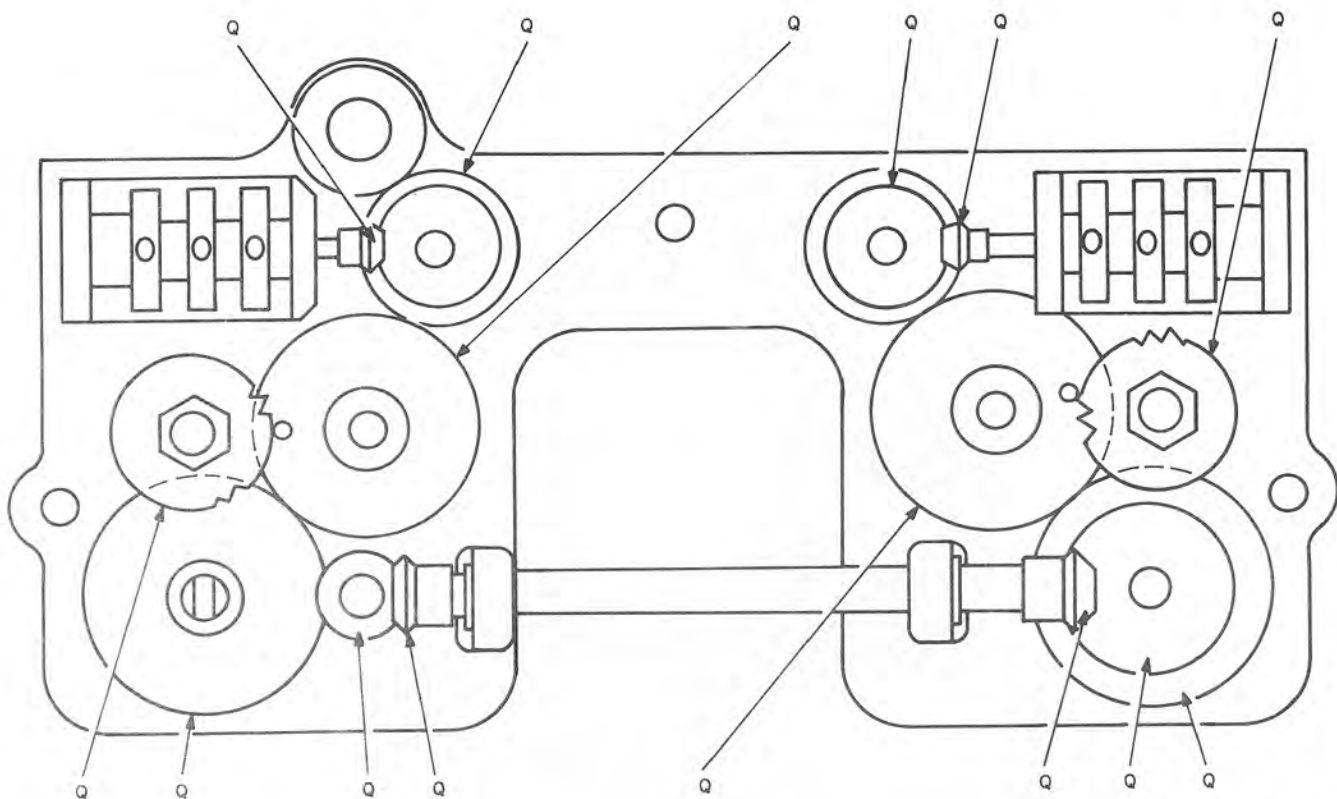

TM5820-520-35-781

Figure 3-50. Amplifier Radio Frequency AM-3349/GRC-106, front panel gear drive assembly, lubrication points.

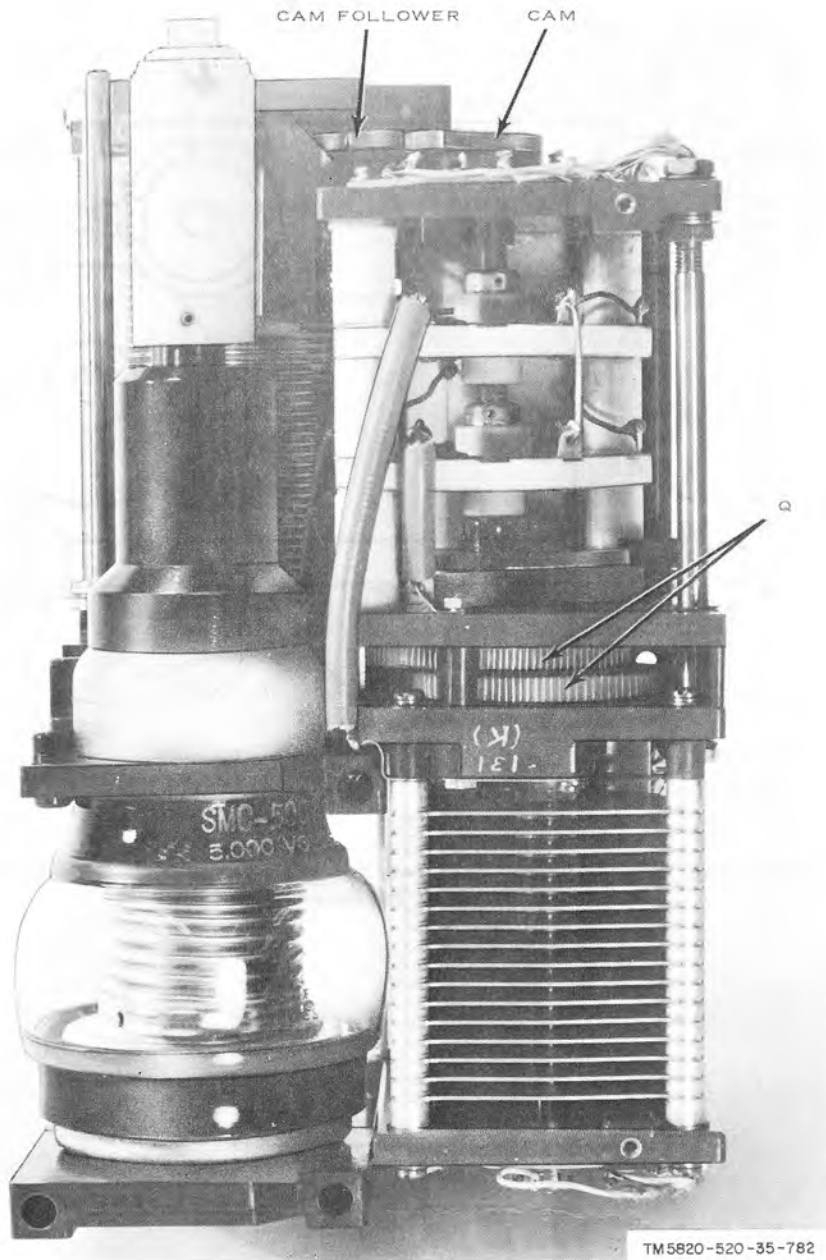

Figure 3-51. Amplifier, Radio Frequency AM-3349/GRC-106, antenna coupler assembly 2A3, lubrication points.

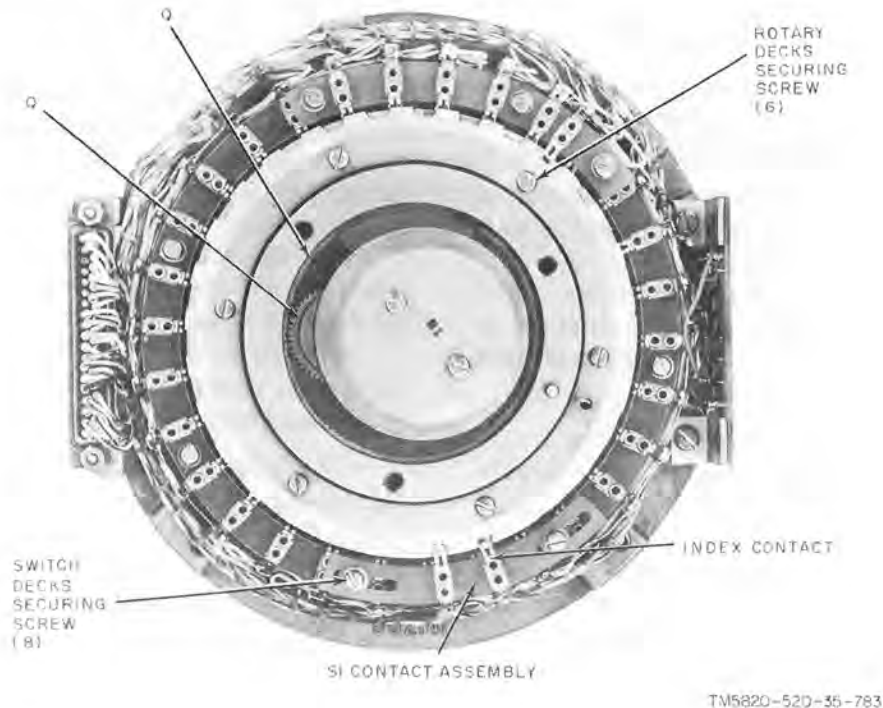

Figure 3-52. Amplifier, Radio Frequency AM-3349/GRC-106, turret assembly 2A2, switch decks.

Section VI. ALIGNMENT AND ADJUSTMENT

3-42. Test Equipment and Special Tools Required for Alignment

The following is a list of test equipment required to perform the procedures contained in this section:

a. Test Equipment.

Item	Technical manual
Signal Generator AN/URM-127 (2 required)	TM 11-6625-683-15
Electronic Counter Digital Readout AN/USM-207	TM 11-6625-700-10
Generator, Signal AN/GRM-50.	TM 11-6625-573-15
Spectrum Analyzer TS-723(*)/U	TM 11-5097
Voltmeter, Electronic AN/URM-145 with adapter 91-8A	TM 11-6625-524-14
Multimeter ME-26(*)/U----	TM 11-6625-200-15

b. Additional Equipment.

- (1) Dummy Load DA-75/U.
- (2) Telegraph Key KY-116/U.
- (3) Power Supply PP-4763(*)/GRC.
- (4) 51 Ohm, 1 watt, 10-percent resistor.
- (5) Adapter, RF-9997.
- (6) Test cables:

(a) Cable Assembly, Special Purpose, Electrical (W23). Part of SM-442A/GRC (FSN 5995-832-6861).

(b) Cable Assembly, R. F. (W25). Part of SM-442A/GRC. (FSN 5995-935-0350).

3-43. Mechanical Alignment of Driver Assembly 2A8

(fig. 2-23)

a. *General.* To insure optimum performance, the mechanical alignment of the stator blocks on driver assembly 2A8 should be checked each time that the assembly is removed or replaced.

b. *Procedure.* To align the stator contacts on driver assembly 2A8 with the contacts on the turret, proceed as follows:

(1) Loosen the six front panel Allen screws and slide out Amplifier, Radio Frequency AM-3349/GRC-106 chassis.

(2) Loosen the three turret drum screws (para 3-37b(1)(c)). This will allow sufficient rotation of the turret drum to observe meshing and unmeshing of the contacts.

(3) Rotate the turret by hand and observe the meshing of the turret contacts with the stator contacts on driver assembly 2A8.

(4) If contacts do not mesh evenly vertically, note the amount of misalignment, and remove the turret drum (para 3-37b(1) and c(1)).

(5) Loosen the three screws that secure the stator block to the wall of driver assembly 2A8 (fig. 2-23), shift the block to eliminate misalignment ((4) above), and tighten the three screws to the point where enough friction is present so that the stator block does not move easily, but still can be repositioned.

(6) Replace the turret drum on the turret base (para 3-37b(2)) and repeat the procedure given in (3) and (4) above. If necessary, shift the stator block. Once the stator block is correctly positioned, remove the turret drum, tighten the three screws on the stator block, replace the turret drum, and repeat the procedures given in (3) and (4) above to be sure that no movement occurred.

(7) Secure the turret drum into its original position with the three turret drum screws (b(2) above).

(8) Slide the chassis back into the case and tighten the front panel Allen screws.

3-44. Stator Assembly 2A9, Mechanical Alignment

(fig. 2-24)

a. General. To insure optimum performance, the mechanical alignment of the stator blocks on stator assembly 2A9 should be checked and adjusted each time that stator assembly 2A9 is removed and replaced.

b. Procedure. To align the stator contacts on the stator assembly 2A9 with the contacts on the turret, proceed as follows:

(1) Loosen the six panel Allen screws and slide the AM-3349/GRC-106 chassis out.

(2) Loosen the three turret drum screws (para 3-37b(1)(c)). This will allow sufficient rotation of the turret drum to observe meshing and unmeshing of the contacts.

(3) Rotate the turret by hand and observe the meshing of the turret contacts with the stator contacts on Stator Assembly 2A9.

(4) If the contacts do not mesh evenly vertically, note the amount of misalignment, and remove the turret drum (para 3-37b(1)(d) and (e)).

(5) Loosen the four screws that secure the stator block to the bracket of stator assembly 2A9 (fig. 2-24). Shift the block to eliminate the misalignment noted in (4) above, and tighten the four screws.

(6) Replace the turret drum on the turret base (para 3-37b(2)(a)) and check by rotating the turret by hand.

(7) When misalignment is corrected, secure the turret drum in its original position with the three turret drum screws (b(2) above).

(8) Slide the chassis back into the case and tighten the front panel Allen screws.

3-45. Turret Assembly 2A2, Electrical Positioning Adjustment

a. General. To insure optimum performance, the turret positioning switches should be adjusted only if the turret base is repaired or replaced. Do not make this adjustment as long as Amplifier, Radio Frequency AM-3349/GRC-106 is operating properly.

WARNING

Voltages up to 3,000 volts dc and 10,000 volts rf exist in the AM-3349/GRC-106. Be extremely careful when working with the equipment operating outside the case. Disconnect the power source and use a shorting stick to ground capacitors 2A5A2C4 and 2A5A-2C5 before touching any components. Wait 15 seconds after turning off set before shorting 2A5 capacitors so as to prevent damage to capacitor 2A5A2C8.

b. Preparatory Procedure. To adjust the turret positioning switches, proceed as follows:

(1) Loosen the six front panel Allen screws and slide the AM-3349/GRC-106 chassis out from the case.

(2) Connect the multiconductor test cable, fabricated in paragraph 2-29, between case connector 2A6XA1 and chassis connector 2A1J1.

c. Test Equipment Required. Connect the test equipment as shown in figure 2-40. Turn on the test equipment and allow a 10-minute warmup period. Set Radio Set AN/GRC-106(*) switches and controls as shown in table 3-35.

Table 3-35. Preliminary Test Equipment Control Settings

Unit	Control	Setting
RT-662/GRC or RT-834/GRC	SERVICE SELECTOR switch	OVEN ON (allow 10 minutes warm-up)
RT-662/GRC or RT-834/GRC	MANUAL RF GAIN control	Fully clockwise
RT-662/GRC or RT-834/GRC	AUDIO GAIN control	Approximately midrange
RT-662/GRC or RT-834/GRC	SQUELCH switch	OFF
RT-662/GRC or RT-834/GRC	FREQ. VERNIER control	OFF
RT-662/GRC or RT-834/GRC	BFO control	Approximately midrange
RT-662/GRC or RT-834/GRC	Vox switch	PUSH TO TALK
AM-3349/GRC-106	PRIM. PWR switch	ON
AM-3349/GRC-106	HV RESET switch	TUNE
RT-662/GRC or RT-834/GRC	SERVICE SELECTOR switch	STAND BY (allow 60 seconds warmup)

d. Procedure.

(1) Set the PP-4763(*)/GRC for an output of 27 volts dc.

(2) Set Receiver-Transmitter, Radio RT-662/GRC or RT-834/GRC SERVICE SELECTOR switch at SSB/NSK. Set the MHz and kHz controls at 02999.

(3) When the tuning cycle is complete, the centers of the turret drum contacts should be aligned with the centers of the stator contacts on driver assembly 2A8 and stator assembly 2A9. If they are not, note the amount of overshoot or undershoot.

(4) Remove the turret drum and base by performing the procedure given in paragraph 3-37b(1) and e(1).

(5) Remove the four screws on the perimeter of the turret base, and lift off the rotary deck cover.

(6) Reinstall the turret base on the chassis (para 3-37c(2)) do not reinstall the turret drum).

(7) Loosen the six screws that secure the rotary decks to the turret base (fig. 3-52). If the turret contacts overshoot, adjust the second and third rotary decks (counting from the top) counterclockwise an amount proportional to the overshoot. If the turret contacts undershoot, adjust the second and third rotary decks, counting from the top clockwise an amount proportional to the undershoot.

CAUTION

Insure that the screws are securely tightened when performing the procedure given in (8) below to avoid damage to the rotary deck contacts.

(8) Tighten the six screws that secure the rotary decks to the turret base, and replace the turret drum (para 3-37b(2)).

(9) Repeat the procedure given in (1), (2), and (3) above. If the turret still overshoots or undershoots, repeat the procedure given in (4) through (8) above.

(10) When the centers of the turret drum contacts align with the centers of the stator contacts on driver assembly 2A8 and stator assembly 2A9, remove the turret drum.

(11) Loosen the two screws on either side of the index contact. Position S1 contact assembly so that the index contact is centered between the two teeth of rotary deck 2A2S1.

(12) Remove the turret base and reinstall the rotary deck cover.

(13) Replace the turret base and turret drum (para 3-37b(2) and e(2)).

(14) Turn off all power and disconnect all test equipment. Disconnect the fabricated test cable.

(15) Slide the chassis back into the case and tighten the front panel Allen screws.

3-46. Driver 2A8V1, Feedback Capacitor Adjustment

a. *General.* To insure optimum performance, feedback capacitor 2A8C2 (fig. 2-23) should be adjusted each time driver tube 2A8V1 or driver assembly 2A8 is replaced.

b. *Test Equipment Required.* Connect Power Supply PP-4763(*)/GRC to Receiver-Transmitter, Radio RT-662/GRC or RT-834/GRC front panel POWER connector and to Amplifier, Radio Frequency AM-3349/GRC-106 front panel PRIM. PWR. connector, the same as shown in figure 2-39. Set the PP-4763(*)/GRC for an output of 27 volts dc. Connect AN/URM-145 as required during procedure. Turn on the test equipment and allow a 5-minute warmup period.

WARNING

Voltage up to 3,000 volts dc and 10,000 volts rf exist in the AM-3349/GRC-106. Be extremely careful when working with the equipment operating outside the case. Disconnect the power source and use a shorting stick to ground capacitors before touching any components. Wait 15 seconds after turning off set before shorting capacitors 2A5A2C5 and C6 so as to prevent damage to 2A5A2C6.

c. Procedure. To adjust feedback capacitor 2A8C2, proceed as follows:

(1) Loosen the six front panel Allen screws and slide the AM-3349/GRC-106 chassis out.

(2) Loosen the four captive screws that secure relay assembly 2A7 to the chassis and remove relay assembly 2A7.

(3) Unsolder the lead from terminal 2A1A1E3. Terminal 2A1A1E3 is located on the 2A1A1 test points area wall, between the PA NEUT ADJ and relay assembly 2A7.

(4) Connect the red clip lead of rf test cable fabricated in paragraph 2-29 to terminal 2A1A1E3. Connect the black lead to the chassis ground.

(5) Set relay assembly 2A7 back in place and secure the four captive screws.

(6) Connect the other end of the fabricated rf test cable to the RT-662/GRC or RT-834/GRC front panel RF DRIVE connector.

(7) Connect the multiconductor test cable fabricated in paragraph 2-29 between case connector 2A6XA1 and chassis connector 2A1J1.

(8) Set AM-3349/GRC-106 PRIM. PWR. circuit breaker at ON.

(9) Set the RT-662/GRC or RT-834/GRC SERVICE SELECTOR switch at CW and set MHz and kHz controls at 29500.

(10) Connect the AN/URM-145 through the 91-8A adapter to the AM-339/GRC-106 front panel RF DRIVE connector.

(11) Set the AM-3349/GRC-106 HV RE-SET switch at TUNE and adjust the AN/URM-145 sensitivity for a center-scale indication.

(12) Use an insulated adjustment tool to adjust FEEDBACK ADJ C2 capacitor 2A8C2 for a null on the AN/URM-145. FEEDBACK ADJ C2 is located close the base of 2A8V1 on assembly 2A8.

(13) Set the PRIM. PWR. circuit breaker at OFF.

(14) Turn off all power. Use a shorting stick to short the plates of power amplifier 2A1A1V1-2A1A1V2 to ground. Disconnect all test equipment. Disconnect the two fabricated test cables.

(15) Loosen the four captive screws that secure relay assembly 2A7 to the chassis and remove assembly 2A7.

(16) Resolder the lead to terminal 2A1A1E3 ((3) above).

(17) Set relay assembly 2A7 back in place and secure with the four captive screws.

(18) Slide the chassis back into the case and tighten the front panel Allen screws.

3-47. Radio Set AN/GRC-106(*), Power Output Adjustment

a. General. To insure optimum performance, the power output adjustment should be performed every time discriminator assembly 2A4, DRIVER TUBE 2A8V1, power amplifier tube 2A1A1V1 or 2A1A1V2, turret assembly 2A2, 100 kHz synthesizer module 1A2, 10 and 1 kHz synthesizer module 1A4, transmitter IF and audio module 1A5, translator module 1A8, MHz synthesizer module 1A9, or rf amplifier module 1A12 is replaced. This adjustment is always accomplished after all other adjustments have been performed.

b. Test Equipment Required. Connect the equipment as shown in figure 3-53. Turn on all equipment and allow a 10-minute warmup period. Set Charger, Battery PP-4763A/GRC for an output of 27 volts dc. Set Radio Set AN/GRC-106(*) switches and controls as listed in table 3-36.

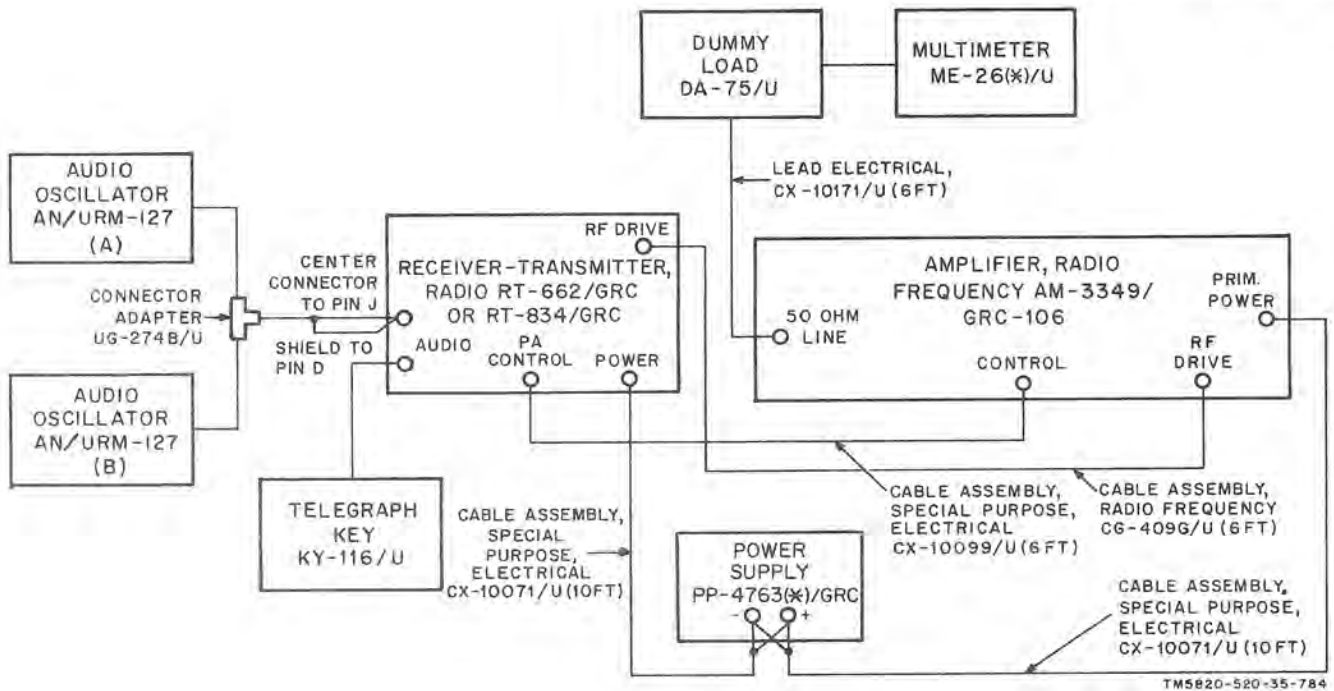

Figure 3-53. Radio Set AN/GRC-106(*) power output adjustment, test setup.

Table 3-36. Power Output Adjustment, Control settings

Unit	Control	Setting
RT-662/GRC or RT-834/GRC	SERVICE SELECTOR switch	OVEN ON (allow 10 minutes warm-up)
RT-662/GRC or RT-834/GRC	MANUAL RF GAIN control	Fully clockwise
RT-662/GRC or RT-834/GRC	AUDIO GAIN control	Approximately midrange
RT-662/GRC or RT-834/GRC	SQUELCH switch	OFF
RT-662/GRC or RT-834/GRC	FREQ. VERNIER control	OFF
RT-662/GRC or RT-834/GRC	BFO control	Approximately midrange
RT-662/GRC or RT-834/GRC	Vox switch	PUSH TO TALK
AM-3349/GRC-106	PRIM. PWR switch	ON
RT-662/GRC or RT-834/GRC	SERVICE SELECTOR switch	STANDBY (allow 60 seconds warm-up)

c. Procedure. To check and adjust Radio AN/GRC-106(*) power output, proceed as follows:

WARNING

Voltages up to 3,000 volts dc and 10,000 volts rf exist in the AM-3349/GRC-106. Be extremely careful when working with the equipment operating outside the case. Disconnect the power source and use a shorting stick to ground the capacitors before touching any components. After turning off set, wait 15 seconds before shorting capacitors 2A5A2C5 and C6 in order to prevent damage to 2A5A2C6.

(1) Loosen the six front panel Allen screws and slide the RT-662/GRC or RT-834/GRC chassis out about 2 inches.

(2) Loosen the two screws and slide the cover of the APC, PPC, and TUNE controls out of the way. The cover is located on the rear, top side of the front panel.

(3) Set the SERVICE SELECTOR switch at SSB/NSK.

(4) Set the MHz and kHz controls to 29.500.

(5) Rotate the AM-3349/GRC-106 ANT. LOAD and ANT. TUNE controls until the counters indicate the readings shown on the antenna tuning and loading chart for a 50 ohm load and a frequency of 29.500 MHz.

(6) Set the AM-3349/GRC-106 HV RE-SET switch at TUNE.

(7) Simultaneously adjust the AM-3349/GRC-106 ANT. TUNE and ANT. LOAD controls until the meters indicate in the center portion of the scales.

(8) Adjust the RT-662/GRC or RT-834/GRC TUNE control 1A1R13 ((2) above) until the ME-26(*)/U indicates 65 volts.

(9) Set the RT-662/GRC or RT-834/GRC SERVICE SELECTOR switch at FSK.

(10) Disconnect the AN/URM-127 (A). Set the AN/URM-127 (B) for an output of 1.5 kHz at a level of 200 mv.

(11) Set the AM-3349/GRC-106 HV RESET switch at OPERATE and key the AN/GRC-106(*) with the KY-116/U.

(12) Adjust the RT-662/GRC or RT-834/GRC APC control 1A1R14 ((2) above) until the ME-26(*)/U indicates 105 volts.

(13) Disconnect the AN/URM-127 (B). Reconnect the AN/URM-127 to the connector adapter UG-274B/U and set for an output of 2.5 kHz at a level of 200 mv. Reconnect the AN/URM-127 (B).

(14) Depress the KY-116/U. Adjust PPC control 1A1R15 ((2) above) until the ME-26(*)/U indicates 155 volts.

(15) Set the RT-662/GRC or RT-834/GRC SERVICE SELECTOR switch at SSB NSK and key the AN/GRC-106(*) with the KY-116/U.

(16) The ME-26(*)/U should indicate 141 volts ± 5 .

(17) Set the SERVICE SELECTOR switch at AM. Disconnect the AN/URM-127's. Depress the KY-116/U. The ME-26(*)/U should indicate 59 volts ± 4 .

(18) Set the RT-662/GRC or RT-834/GRC SERVICE SELECTOR switch at CW. Install a 510 Ω resistor in series with the white lead on the key KY-116/U and depress key. The ME-26(*)/U should indicate 100 volts ± 5 .

(19) If the indications are not correct as indicated in (16) through (18) above, repair or updating is required.

(20) Set the SERVICE SELECTOR switch at OFF.

(21) Turn off all power and disconnect all test equipment.

(22) Slide the cover back over the RT-662/GRC or RT-834/GRC APC, PPC, and TUNE controls and tighten the two screws.

(23) Slide the chassis back into the case and tighten the front panel Allen screws.

3-48. Amplifier, Radio Frequency AM-3349/GRC-106, Automatic Programming Test

a. General. Loosen the front panel Allen screws and slide the AM-3349/GRC-106 out from the case. Remove the four screws from the cover over antenna coupler assembly 2A3, and remove the cover. Set the AM-3349/GRC-106 chassis on top of the RT-662/GRC or RT-834/GRC. Connect the multiconductor test cable fabricated in paragraph 2-29 between case connector 2A6XA1 and chassis connector 2A1J1. Set the output from the PP-4763(*)/GRC at 27 volts dc and connect it to the AM-3349/GRC-106 PRIM. POWER connector and the RT-662/GRC or RT-834/GRC POWER connector. Connect Cable Assembly, Special Purpose, Electrical CX-10099/U between the RT-662/GRC and RT-834/GRC PA CONTROL connector and the AM-3349/GRC-106 CONTROL connector. Set the SERVICE SELECTOR switch to SSB/NSK. Set the AM-3349/GRC-106 PRIM. PWR. switch at ON and the HV RESET switch at TUNE.

WARNING

When performing the visual inspections below, be extremely cautious not to touch any components inside the AM-3349/GRC-106. Voltages as high as 3,000 volts dc are present.

b. Procedure. Set the RT-662/GRC or RT-834/GRC MHz and kHz controls to a frequency in each of the ranges listed in the chart (c below). At each frequency setting, check to be sure that the operating frequency as indicated on the top of turret assembly 2A2 corresponds with the OPERATING FREQUENCY arrow on the top of stator assembly 2A9; also at each frequency setting check to be sure that bandswitch 2A3S1 is in the position (fig. 4-13) indicated in table 3-37. Each time the chart indicates that bandswitch 2A3S1 should be in position 6, check to see that the rotor and stator plates of variable capacitor 2A3C27 are aligned as indicated in the referenced portion of figure 3-54. Connect the UG-201A/U connector adapter to the AM-3349/GRC-106 50 OHM LINE connector. Reset the RT-662/GRC or RT-834/GRC MHz and kHz controls to a frequency in each of the ranges indicated in the chart below. Bandswitch 2A3S1 should remain in position 6 for all frequencies. The position of variable capacitor 2A3C27 rotor and stator plates should be as indicated in the referenced portion of figure 3-54.

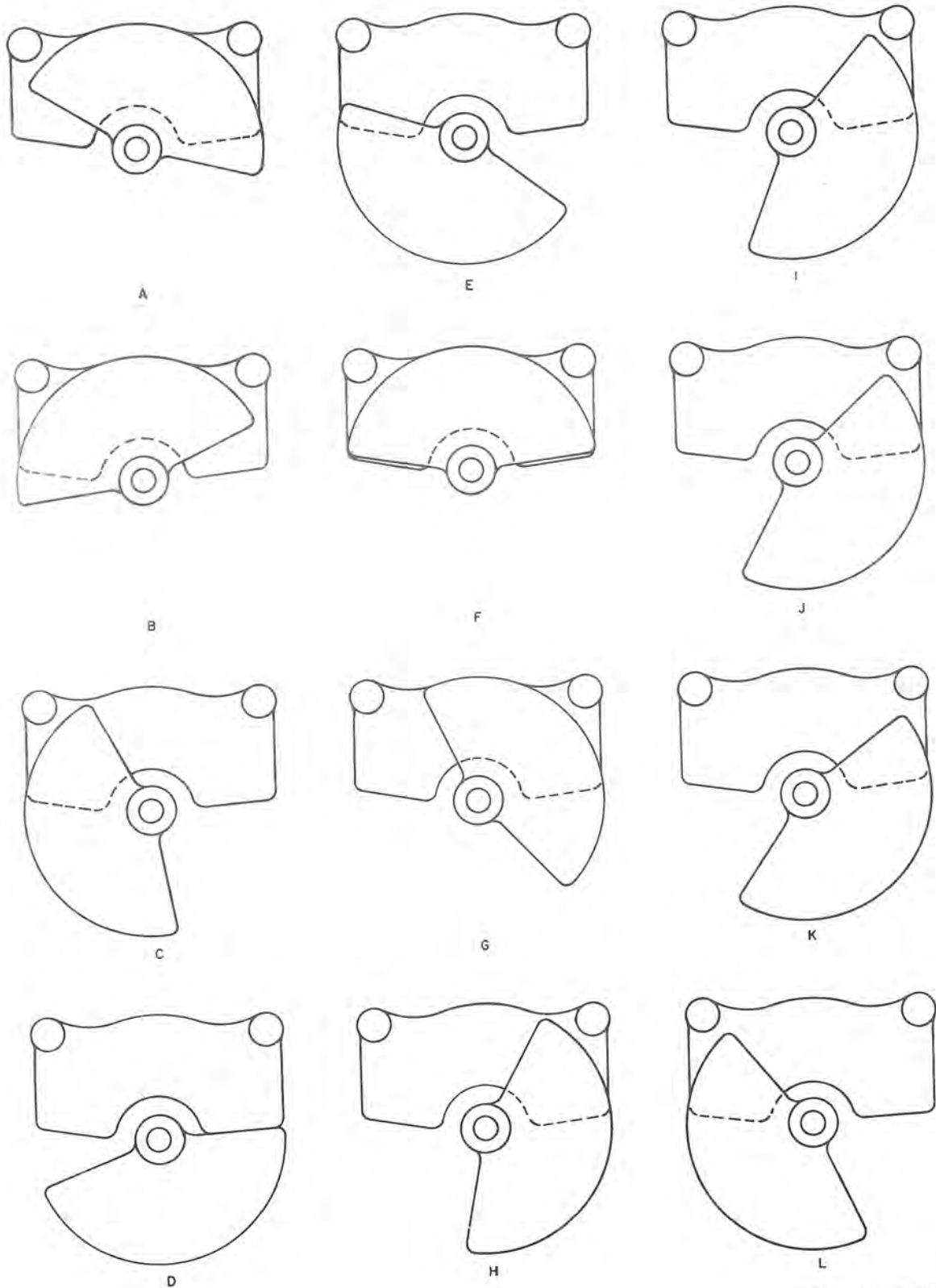

TM5820-520-35-785

Figure 3-54. Variable capacitor 2A3C27 programming configuration.

Table 3-37. MHz and kHz Control Settings for Automatic Programming Test

Channel	Frequency range (MHz)	ASST Position	Figure 3-54 reference Whip	50-ohm line
1	2.000 to 2.499	12		F
9	2.55 to 2.999	10		F
2	3.000 to 3.499	2		F
10	3.500 to 3.999	8		F
21	4.000 to 4.999	4		F
22	5.000 to 5.999	4		G
25	6.00 to 6.999	4		G
26	7.000 to 7.999	4		H
23	8.000 to 8.999	4		H
24	9.000 to 9.999	4		H
29	10.000 to 10.999	6	A	H
30	11.000 to 11.999	6	B	H
27	12.000 to 12.999	6	C	I
28	13.000 to 13.999	6	C	I
3	14.000 to 14.999	6	D	J

Table 3-37. MHz and kHz Control Settings for Automatic Programming Test—Continued

Channel	Frequency range (MHz)	ASST Position	Figure 3-54 reference Whip	50-ohm line
4	15.000 to 15.999	6	E	J
7	16.000 to 16.999	6	E	J
8	17.000 to 17.999	6	E	J
11	18.000 to 18.999	6	E	J
12	19.000 to 19.999	6	E	K
17	20.000 to 20.999	6	E	K
18	21.000 to 21.999	6	E	K
19	22.000 to 22.999	4		K
20	23.000 to 23.999	4		K
5	24.000 to 24.999	4		L
6	25.000 to 25.999	4		L
13	26.000 to 26.999	4		L
14	27.000 to 27.999	6	D	L
15	28.000 to 28.999	6	D	L
16	29.000 to 29.999	6	D	L

Section VII. GENERAL SUPPORT TESTING PROCEDURES

3-49. General

Testing procedures are for use by general support maintenance personnel to determine the acceptability of repaired equipment. These test procedures set forth specific requirements that repaired electronic equipment must meet before being returned to the using organization. The test procedures include the test in this section, and the module test procedures which are covered in chapter 4. Use table 3-37 for the Automatic Programming Test. The test equipment requirements and test setups for this section are shown in figures 3-55 through 3-71. See para-

graph 3-2 for the complete nomenclature of test equipment. Cables, load adapters, and tee connector adapters shown in figures 3-55 through 3-71 are supplied with Simulator, Radio Frequency SM-442A/GRC.

3-50. Module Tests

The module tests of chapter 4 may be performed after or before the tests in this section. Which tests will be performed first will generally be dependent upon the type of repair that was required. The module tests are covered in tables 4-1 through 4-18.

Table 3-38. Frequency Accuracy and Vernier Tuning Tests

Step	Operation of test equipment	Control settings and operation of equipment	Performance standard
1	Connect equipment as shown in figure 3-55.		
	NOTE If the RT-834/GRC or RT-662/GRC is interconnected with the AM-3349/GRC-106, these connections must be removed before proceeding with the following tests.		
2	Test set preliminary settings: Refer to TM 11-6625-847-12 for preliminary control settings.		
3		RT-834/GRC or RT-662/GRC preliminary settings: a. SERVICE SELECTOR switch to SSB/NSK b. SQUELCH switch to OFF. c. FREQ VERNIER control to OFF. d. MANUAL RF GAIN control fully clockwise. e. AUDIO GAIN control fully counterclockwise. f. Frequency controls to 02000. g. Vox switch to PUSH TO TALK.	

Table 3-38. Frequency Accuracy and Vernier Tuning Test—Continued

Step	Operation of test equipment	Control settings and operation of equipment	Performance standard
4	SM-442A/GRC (test set) settings: a. KEY switch to OFF. b. SERV SEL switch to SSB/NSK. c. PA-RT switch to RT.		
5	Apply power to all equipment. Allow one hour for warmup.		
6		Adjust dc power supply to 27 vdc.	
7	Adjust variable attenuator for 20 db.		
8	Set AN/USM-207 to count up to 10 MHz.		
9	-----	Set RT-834/GRC or RT-662/GRC SERVICE SELECTOR switch to AM	
10	Connect cable W2 from RT-834/GRC or RT-662/GRC FREQ STD connector to signal input connector on AN/USM-207. Observe indication of AN/USM-207.	-----	5 MHz ±0.0 Hz.
NOTE			
If one month has passed since the standard was adjusted, check the need to reset the crystal oscillator to the low side of the tolerance.			
11	Disconnect cable W2 from AN/USM-207 input.		
NOTE			
Throughout this test observe several indications of the frequency to determine that the frequency is stable. If the last digit is varying by one count select the digit which appears most often.			
12	Connect cable W1 from CN-764/U attenuator to AN/USM-207 input.		
13	Key RT-834/GRC or RT-662/GRC by setting the test set KEY switch to ON. Observe indication on AN/USM-207.		2 MHz +0.0, -0.3 Hz, ±1 count.
14	Set test set KEY switch to OFF.		
15	-----	Set RT-834/GRC or RT-662/GRC frequency controls to 031111.	
16	Key RT-834/GRC or RT-662/GRC by setting the test set KEY switch to ON. Observe indication of AN/USM-207 and compare with step 13 listing.		3.1111 MHz +0.0, -0.3 Hz, ±1 count
17	Set the test set KEY switch to OFF.		
18	-----	Repeat steps 14 through 17 with RT-834/GRC or RT-662/GRC frequency controls set successsively (in step 15) to the settings listed be-	

Table 3-38. Frequency Accuracy and Vernier Tuning Test—Continued

Step	Operation of test equipment	Control settings and operation of equipment	Performance standard
		low. All frequency indications on the AN/USM-207 should be the same as indicated on the frequency controls at each setting, plus or minus the indicated frequency tolerance. (Reset AN/USM-207 for changing frequencies as necessary.)	
		NOTE	
		Although a plus or minus tolerance is given, the output frequency error must be in the same direction as that of frequency standard.	
		For the RT-662/GRC the last digit is omitted for each of the following frequencies.	
		MHz and kHz Control Settings:	Frequency Tolerance (-Hz \pm 1 count)
		031111-----	1.16
		042222-----	2.2
		053333-----	2.8
		064444-----	3.3
		075555-----	3.9
		086666-----	4.4
		090000-----	4.6
		107777-----	5.5
		114000-----	5.8
		127000-----	6.5
		131000-----	6.7
		148000-----	7.5
		150000-----	7.6
		160000-----	8.1
		172000-----	8.7
		183000-----	9.3
		195000-----	9.9
		206000-----	10.4
		218888-----	11.0
		220000-----	11.1
		230000-----	11.6
		249000-----	12.5
		250000-----	12.6
		260000-----	13.1
		270000-----	13.6
		280009-----	14.1
		299990-----	15.1
19	-----	Set RT-834/GRC or RT-662/GRC frequency controls to 02000 and the SERVICE SELECTOR switch to CW.	
20	Key RT-834/GRC or RT-662/GRC by setting the test set KEY switch to ON. Observe the indication on the AN/USM-207.	-----	2.002 MHz \pm 0.3 Hz
21	Set the test set KEY switch to OFF.		
22	Disconnect test cable W1 from AN/USM-207 input connector.		
23	Connect cable W5 from test set AUDIO OUT/DMW	Connect cable W2 between FREQ STD connector and RECEIVER IN con-	

Table 3-38. Frequency Accuracy and Vernier Tuning Tests—Continued

Step	Operation of test equipment	Control settings and operation of equipment	Performance standard
	connector to AN/USM-207 signal input connector.	nect on RT-834/GRC or RT-662/GRC. Set AUDIO GAIN control fully clockwise.	
24		Set RT-834/GRC or RT-662/GRC frequency controls to 04998 and SERVICE SELECTOR to SSB. Observe indication on AN/USM-207.	2000 Hz ±1 count.
25		Rotate RT-834/GRC or RT-662/GRC FREQ VERNIER control fully counterclockwise (but not to OFF) and observe the AN/USM-207 indication.	2,600 Hz ±100
26		Rotate RT-834/GRC or RT-662/GRC FREQ VERNIER control fully clockwise and observe the AN/USM-207 indication.	1,400 Hz ±100
27		Rotate RT-834/GRC or RT-662/GRC FREQ VERNIER control to OFF.	
28	Disconnect all test cables.		

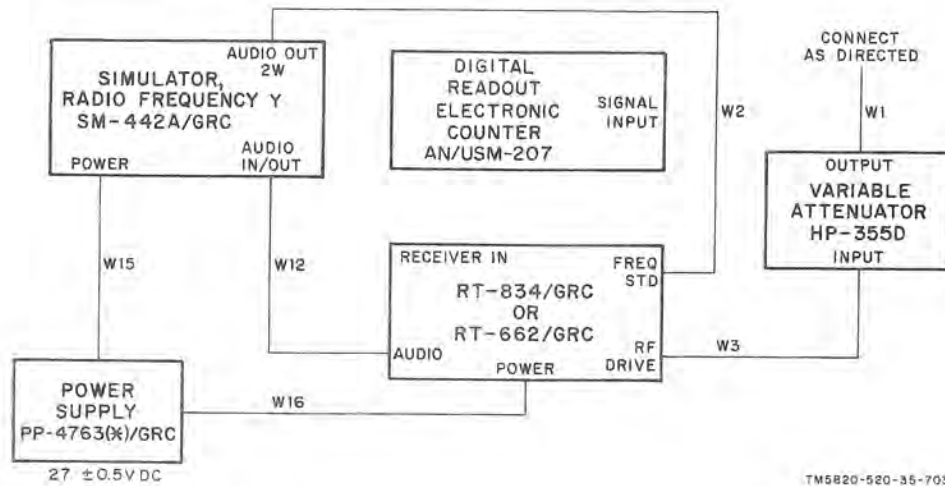

Figure 3-55. Frequency accuracy and vernier tuning tests, connection diagram.

Table 3-39. Audio Power Circuit and Overall Gain Test

Step	Operation of test equipment	Control settings and operation of equipment	Performance standard
1	Connect equipment as shown in figure 3-56.		

NOTE

If the RT-834/GRC or RT-662/GRC is interconnected with the AM-3349/GRC-106, these connections must be removed before proceeding with the following tests.

- 2 Test set preliminary settings: Refer to TM 11-6625-847-12 for preliminary control settings.

Table 3-39. Audio Power Circuit and Overall Gain Test—Continued

Step	Operation of test equipment	Control settings and operation of equipment	Performance standard
3	-----	RT-834/GRC or RT-662/ preliminary settings: a. SERVICE SELECTOR switch to SSB/FSK. b. SQUELCH switch to OFF. c. FREQ VERNIER control to OFF. d. MANUAL RF GAIN control fully clockwise. e. AUDIO gain control fully counterclockwise. f. Frequency controls to 02000. g. Vox switch to PUSH TO TALK	
4	SM-442A/GRC (test set) settings: a. REC-XMIT switch to REC. b. KEY switch to OFF: c. SERV SEL switch to SSB/NSK. d. PA-RT switch to RT. e. XMIT STATUS switch to OPERATE.		
5	Apply power to all equipment. Allow 15 minutes for warmup.		
6	Adjust variable attenuator for 100 dB attenuation.		
7	Set AN/USM-207 on its internal standard.		
8	Set AN/GRM-50 for unmodulated cw with 3.0 v rms output at 2.001 MHz as indicated on AN/USM-207.	-----	2.001 MHz \pm 100 Hz.
9	Disconnect the AN/USM-207 from the AN/GRM-50.		
10	Connect cable W2 from CN-764/U directly to the RF OUT connector on the AN/GRM-50.		
11	Connect Cable W8 from the ME-30(*)/U meter input to the test set AUDIO OUT 10 MW jack.	Set the RT-834/GRC or RT-662/GRC AUDIO GAIN control fully clockwise.	
12	Set the ME-30(*)/U for 3 vac range. Observe meter indication.	-----	2.33 v rms minimum.
13	-----	Rotate the RT-834/GRC or RT-662/GRC AUDIO GAIN control fully counterclockwise.	0.7 v rms maximum.
14	Disconnect cable W8 from the AUDIO OUTPUT 10 MW jack and connect it to the AUDIO OUT 2W jack of the test set. Observe audio output.	-----	0.7 v rms maximum. Note that audio level decreases smoothly during ccw rotation.
15	-----	Set RT-834/GRC or RT-662/GRC AUDIO GAIN control fully clockwise.	31.3 v rms minimum.
16	Disconnect all test cables.		

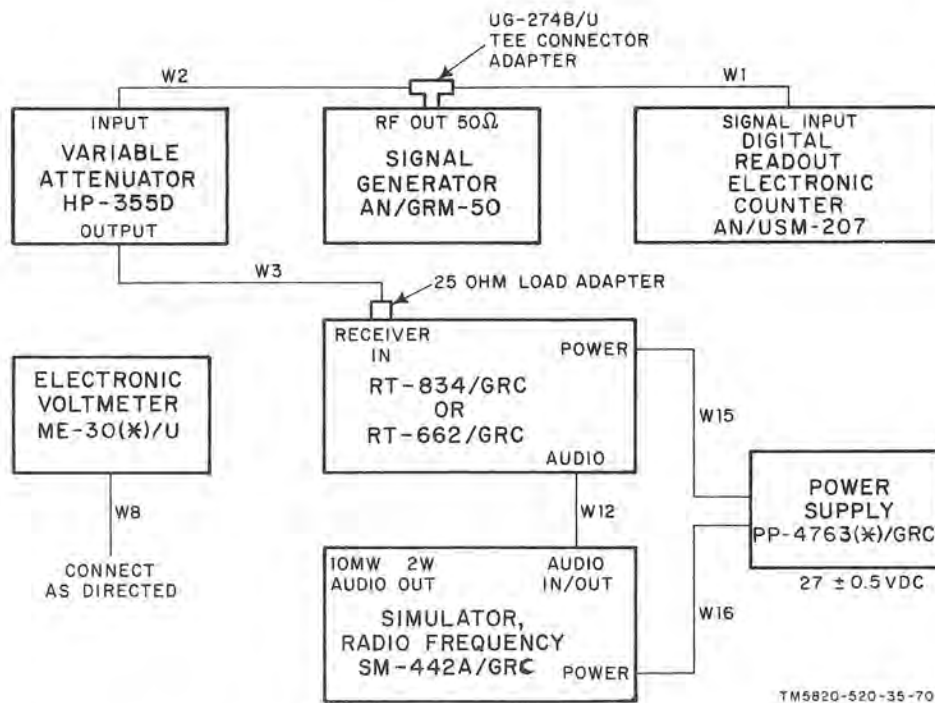

TM5820-520-35-704

Figure 3-56. Audio power circuit and overall gain tests, connection diagram.

Table 3-40. Audio Distortion Test

Step	Operation of test equipment	Control settings and operation of equipment	Performance standard
1	Connect equipment as shown in figure 3-57.		
NOTE			
If the RT-834/GRC or RT-662/GRC is interconnected with the AM-3349/GRC-106, these connections must be removed before proceeding with the following tests.			
2	Test set preliminary settings: Refer to TM 11-6625-847-12 for preliminary control settings.		
3	----- RT-834/GRC or RT-662/GRC preliminary settings:		
		a. SERVICE SELECTOR switch to SSB/FSK.	
		b. SQUELCH switch to OFF.	
		c. FREQ VERNIER control to OFF.	
		d. MANUAL RF GAIN control fully clockwise.	
		e. AUDIO GAIN control fully counterclockwise.	
		f. Frequency controls to 02000.	
		g. Vox switch to PUSH TO TALK.	

Table 3-40. Audio Distortion Test—Continued

Step	Operation of test equipment	Control settings and operation of equipment	Performance standard
4	SM-442A/GRC (test set) settings: a. REC-XMIT switch to REC. b. KEY switch to OFF. c. SERV SEL switch to SSB/NSK. d. PA-RT switch to RT. e. XMIT STATUS switch to OPERATE.		
5	Apply power to all equipment. Allow 15 minutes for warmup.		
6	Set the AN/GRM-50 for an unmodulated cw output of 1.0 v rms at 2.001 MHz ± 100 Hz as indicated on the AN/USM-207. Set CN-764/U to zero.		
7	Connect cable W9 from the ME-30(*)/U input connector to the test set AUDIO OUT 10 MW connector.		
8	-----	Adjust RT-834/GRC or RT-662/GRC AUDIO GAIN control for a 2.45 v rms or a maximum indication whichever is least on the ME-30(*)/U.	
9	Disconnect cable W9 from the test set AUDIO OUT 10 MW connector. Connect cable W8 between TS-723D and input connector to the test set AUDIO OUT 10 MW connector. Measure audio distortion at 1000 Hz, ± 100 Hz.	-----	1.0% maximum.
10	Disconnect cable W8 from the test set AUDIO OUT 10 MW connector. Connect cable W9 from the ME-30(*)/U input connector to the test set AUDIO OUT 2W connector.		
11	-----	Adjust the RT-834/GRC or RT-662/GRC AUDIO GAIN control for a maximum or 34.6 v rms whichever is the least indication on the ME-30(*)/U front panel meter.	
12	Disconnect cable W9 from the test set AUDIO OUT 2W connector. Connect cable W8 between the distortion analyzer and input connector to the test set AUDIO OUT 2W connector. Measure audio distortion.	-----	5% maximum.
13	Disconnect all test cables.		

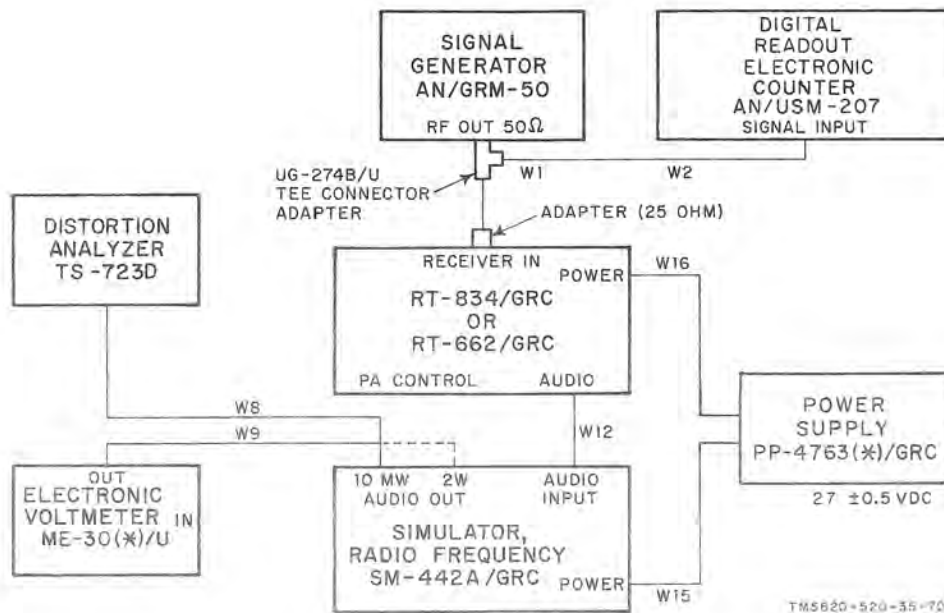

Figure 3-57. Audio distortion Tests, connection diagram.

Table 3-41. Vox Operation, Rf Power Output, Transmit Audio, and Transmit Agc Test

Step	Operation of test equipment	Control settings and operation of equipment	Performance standard
1	Connect equipment as shown in figure 3-58.		
	<p>NOTE If the RT-834/GRC or RT-662/GRC is interconnected with the AM-3349/GRC-106, these connections must be removed before proceeding with the following tests.</p>		
2	Test set preliminary settings: Refer to TM 11-6625-847-12 for preliminary control settings.		
3	-----	RT-834/GRC or RT-662/GRC preliminary settings. a. SERVICE SELECTOR switch to SSB/FSK. b. SQUELCH switch to OFF. c. FREQ VERNIER control to OFF. d. MANUAL RF GAIN control fully clockwise. e. AUDIO GAIN control fully counterclockwise. f. VOX switch to PUSH TO TALK. g. Frequency controls to 04998.	
4	SM-442A/GRC (test set) settings: a. SERV SEL switch to SSB/NSK. b. PA-RT switch to RT. c. KEY switch to OFF.		
5	Apply power to all equipment. Allow 15 minutes for warmup.		

Table 3-41. *Vox Operation, Rf Power Output, Transmit Audio and Transmit Age Test—Continued*

Step	Operation of test equipment	Control settings and operation of equipment	Performance standard
6	-----	Set RT-834/GRC or RT-662/GRC SERVICE SELECTOR switch to SSB/NSK and adjust AUDIO GAIN control for comfortable listening.	
7	Adjust CN-764/U for 20 db attenuation to multiply meter scale indications on AN/URM-145 by 10. Set AN/URM-145 for 1 vac scale (now equal to 10 volts full scale) and connect to CN-764/U.		
8	Connect AN/URM-127 to test set AUDIO IN 600 Ω.	Set AN/GRM-50 for a frequency of 500 Hz and an output of 200 mv rms as measured by ME-30(*)/U.	
9	Key RT-834/GRC or RT-662/GRC by setting test set KEY switch to ON.	-----	AN/URM-145 meter should indicate at least 3 v rms and tone from loudspeaker should stop.
10	Set test set KEY switch to OFF.	-----	Tone should be heard again from loudspeaker and no indication should be on the AN/URM-145.
11	-----	Set RT-834/GRC or RT-662/GRC VOX switch to PUSH TO VOX.	
12	Adjust AN/GRM-50 for output of 10 mv rms.		
13	Key RT-834/GRC or RT-662/GRC by setting test set KEY switch to ON.	-----	AN/URM-145 should indicate a minimum of 3 v rms and tone from loudspeaker should stop.
14	Set test set KEY switch to OFF.	-----	Tone should be heard again from loudspeaker and no indication should be on the AN/URM-145.
15	Adjust AN/GRM-50 for output of 3 mv rms.		
16	Key RT-834/GRC or RT-662/GRC by setting test set KEY switch to ON.	-----	Tone should continue from loudspeaker and no indication should be on the AN/URM-145.
17	Set test set KEY switch to OFF.	-----	Tone should continue from loudspeaker and no indication should be on the voltmeter.
18	-----	Set RT-834/GRC or RT-662/GRC VOX switch to VOX.	
19	Adjust AN/GRM-50 for output of 10 mv rms.	-----	AN/URM-145 meter should indicate at least 0.3 v rms and tone from loudspeaker should stop.
20	-----	Set RT-834/GRC or RT-662/GRC VOX switch to PUSH TO TALK.	
21	Set AN/GRM-50 for a frequency of 1,000 Hz and adjust for output of 20 mv rms.		
22	Key RT-834/GRC or RT-662/GRC by setting test set KEY switch to ON.	-----	AN/URM-145 meter should indicate not less than 0.3 v rms.
23	Set test set KEY switch to OFF.	Set RT-834/GRC or RT-662/GRC frequency controls to each frequency setting listed below in MHz. At each frequency, key the RT-834/GRC or RT-662/GRC (from test set) and observe that a voltage level of not less than 3.0 v is maintained.	

Table 3-41. Vox Operation, Rf Power Output, Transmit Audio and Transmit Agc Test—Continued

Step	Operation of test equipment	Control settings and operation of equipment	Performance standard
NOTE			
For RT-834/GRC the 100 Hz control remains in the 0 position for each of the following frequencies.			
		2.000 MHz-----17.200 MHz	
		3.111-----18.300	
		4.222-----19.500	
		5.333-----20.600	
		6.444-----21.888	
		7.555-----22.000	
		8.666-----23.000	
		9.000-----24.900	
		10.777-----25.000	
		11.400-----26.000	
		12.700-----27.000	
		13.100-----28.000	
		14.800-----29.999	
		15.000	
		16.000	
24	-----	Set RT-834/GRC or RT-662/GRC frequency controls to 02000.	
25	Disconnect the AN/GRM-50.		
26	-----	Set RT-834/GRC or RT-662/GRC SERVICE SELECTOR switch to CW.	
27	Key the RT-834/GRC or RT-662/GRC by setting test set KEY switch to ON.		AN/URM-145 should indicate at least 0.3 v rms.
28	Set test set KEY switch to OFF.		
29	-----	Set RT-834/GRC or RT-662/GRC SERVICE SELECTOR switch to AM.	
30	Key RT-834/GRC or RT-662/GRC by setting test set KEY switch to ON.		AN/URM-145 should indicate at least 0.3 v rms.
31	Set test set KEY switch to OFF.		
32	Disconnect all test cables.		

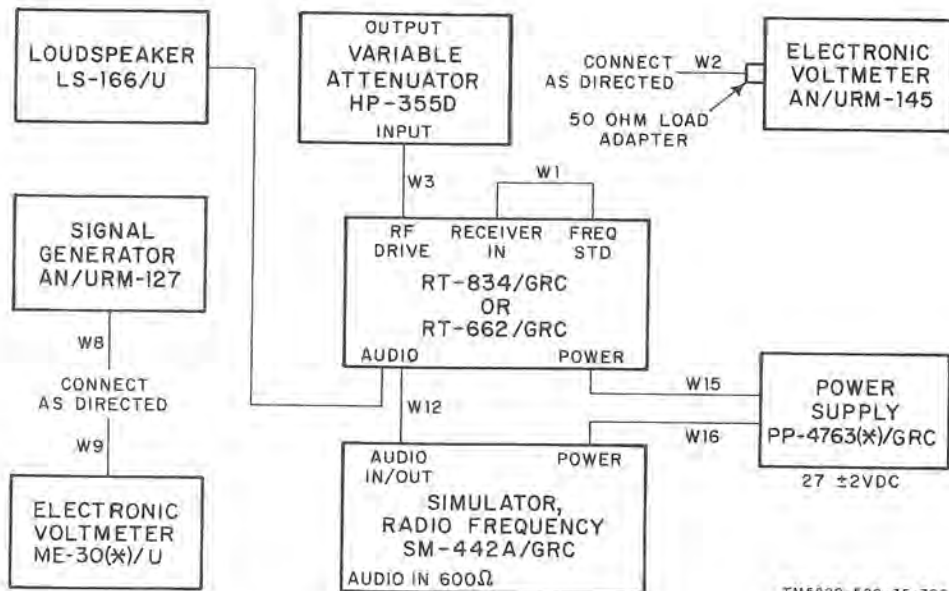

TM5820-520-35-706

Figure 3-58. Vox operation tests, connection diagram.

Table 3-42. Squelch Test

Step	Operation of test equipment	Control settings and operation of equipment	Performance standard
1	Connect equipment as shown in figure 3-59.		
	NOTE		
	If the RT-834/GRC or RT-662/GRC is interconnected with the AM-3349/GRC-106, these connections must be removed before proceeding with the following tests.		
2	Test set preliminary settings: Refer to TM 11-6625-847-12 for preliminary control settings.		
3		----- RT-834/GRC or RT-662/GRC preliminary settings: a. SERVICE SELECTOR switch to STANDBY. b. SQUELCH switch to OFF. c. FREQ VERNIER control to OFF. d. MANUAL RF GAIN control fully clockwise. e. AUDIO GAIN control fully counterclockwise. f. Frequency controls to 02001. g. VOX switch to PUSH TO TALK.	
4	SM-442A/GRC (test set) settings: a. KEY switch to OFF. b. SERV SEL switch to SSB/NSK. c. PA-RT switch to RT. d. REC-XMIT switch to REC.		
5	Apply power to all equipment. Allow 15 minutes for warmup.		
6	Adjust CN-764/U for 120 dB attenuation.		
7	Set AN/GRM-50 for an unmodulated cw signal with a 300 mv rms output at 2.0015 MHz \pm 50 Hz as indicated on AN/USM-207.	----- 2.0015 MHz \pm 50 Hz.	
8		----- Set RT-834/GRC or RT-662/GRC SERVICE SELECTOR switch to SSB/NSK and adjust AUDIO GAIN control for 245 mv rms indication on the ME-30(*)/U.	
9		----- Set RT-834/GRC or RT-662/GRC SQUELCH switch to ON.	No change in audio level.
10		----- Set RT-834/GRC or RT-662/GRC frequency controls to 2.000 MHz and note time required for the RT-834/GRC or RT-662/GRC squelch, as indicated by an abrupt drop in the ME-30(*)/U indication.	5 \pm 3 seconds to meter indication drop-off.
11	Disconnect all test cables.		

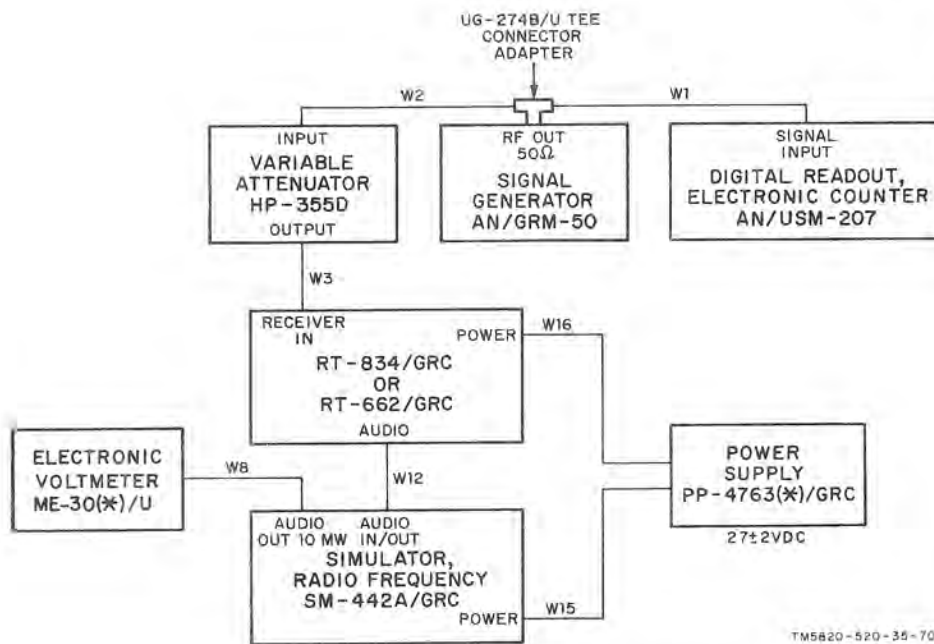

TM5820-520-35-707

Figure 3-59. Squelch tests, connection diagram.

Table 3-43. Agc Test

Step	Operation of test equipment	Control settings and operation of equipment	Performance standard.
1	Connect equipment as shown in figure 3-60.		
	<p>NOTE If the RT-834/GRC or RT-662/GRC is interconnected with the AM-3349/GRC, these connections must be removed before proceeding with the following tests.</p>		
2	Test set preliminary settings: Refer to TM 11-6625-847-12 for preliminary control settings.		
3	-----	RT-834/GRC or RT-662/GRC preliminary settings: a. SERVICE SELECTOR switch to SSB/FSK. b. SQUELCH switch to OFF. c. FREQ VERNIER control to OFF. d. MANUAL RF GAIN control fully clockwise. e. AUDIO GAIN control fully counterclockwise. f. Frequency controls to 02000. g. VOX switch to PUSH TO TALK.	
4	SM-442A/GRC (test set) settings: a. KEY switch to OFF. b. SERV SEL switch to SSB/FSK. c. PA-RT switch to RT. d. REC-XMIT switch to REC.		

Table 3-43. Age Test—Continued

Step	Operation of test equipment	Control settings and operation of equipment	Performance standard
5	Apply power to all equipment. Allow 15 minutes for warmup.		
6	Set CN-764/U to 100 dB.		
7	Set AN/GRM-50 for an unmodulated cw output of 500 mv rms at 2,001 MHz \pm 100 Hz, with AN/USM-207.		
8	-----	Adjust RT-834/GRC or RT-662/GRC AUDIO GAIN control for ME-30(*)/U meter indication of 0 dB on 100 mv scale.	ME-30(*)/U indication 0 dB.
9	Increase AN/GRM-50 output to 1.0 v rms and decrease CU-764/U to 0 dB.	-----	Less than 8 dB increase indicated on meter from reference level established in step 8 above.
10	Disconnect all test cables.		

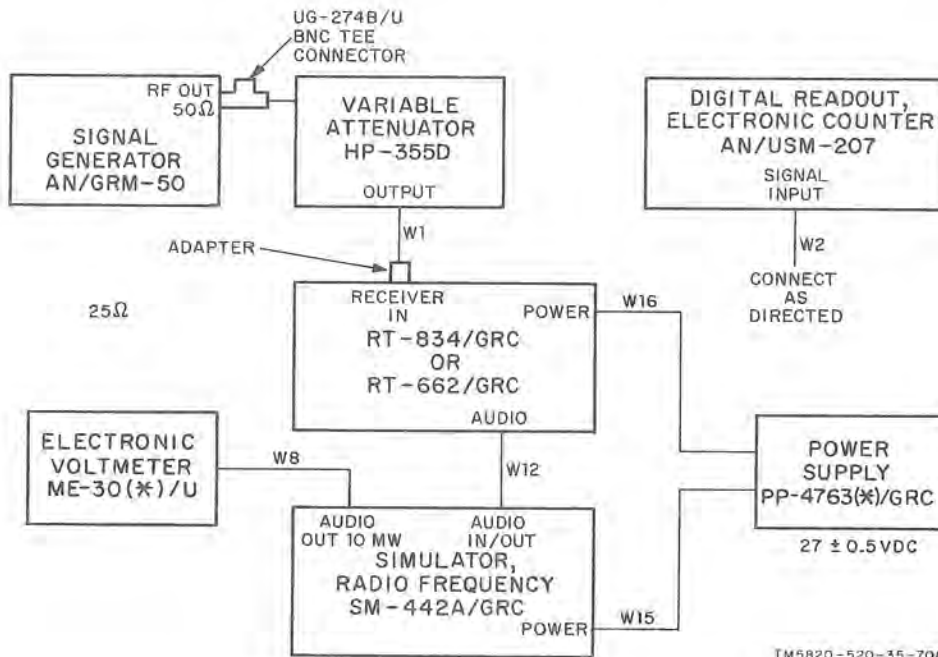

TM5820-520-35-708

Figure 3-60. Age tests, connection diagram.

Table 3-44. Receiver Frequency Response and IF Bandwidth Test

Step	Operation of test equipment	Control settings and operation of equipment	Performance standard
1	-----	Loosen captive screws on front of RT-834/GRC or RT-662/GRC and slide chassis out of case. Set agc/alc switch, 1A1S11, located under right rear corner of chassis (close to module A5), to off (up position). See figure 2-27 for switch location.	
2	-----	Fasten RT-834/GRC or RT-662/GRC back in case.	
3	Connect equipment as shown in figure 3-61.		

NOTE

If the RT-834/GRC or RT-662/GRC is interconnected with the

Table 3-44. Receiver Frequency Response and IF Bandwidth Test—Continued

Step	Operation of test equipment	Control settings and operation of equipment	Performance standard
	AM-3349/GRC-106, these connections must be removed before proceeding with the following tests.		
4	Test set settings: Refer to TM 11-6625-847-12 for preliminary control settings.		
5	Apply power to all equipment. Allow 15 minutes for warmup.		
6	SM-442A/GRC (test set) settings: a. KEY switch to OFF. b. SERV SEL switch to SSB/NSK. c. PA-RT switch to RT. d. REC-XMIT switch to REC. e. XMIT-OPERATE switch to OPERATE.	RT-834/GRC or RT-662/GRC preliminary settings: a. SERVICE SELECTOR switch to SSB/FSK. b. SQUELCH switch to OFF. c. FREQ VERNIER control to OFF. d. MANUAL RF GAIN control fully clockwise. e. AUDIO GAIN control fully counterclockwise. f. Frequency controls to 02000. g. VOX switch to PUSH TO TALK. h. On sets with NOISE BLANKER switch, set this switch at OFF.	
7	Adjust the CN-764/U for 80 db attenuation.		
8	Set AN/GRM-50 for unmodulated cw at 2.001 MHz, as indicated on AN/USM-207.		----- 2.001 MHz \pm 100 Hz.
9	Adjust the AN/GRM-50 output to 150 mv rms as indicated on the ME-30(*)/U.		
10	Connect the AN/URM-145 to the RT-834/GRC or RT-662/GRC IF OUT connector (connect with tee connector and a 50-ohm load in parallel, as shown in test setup, figure 3-61).	Adjust RT-834/GRC or RT-662/GRC MANUAL RF GAIN control for an if. output of 25 mv rms as indicated on the AN/URM-145. Adjust the variable attenuator for 70 db attenuation.	
11	Connect the ME-26(*)/U to the test set AUDIO OUT 10 MW connector.	Adjust the RT-834/GRC or RT-662/GRC AUDIO GAIN control for an audio output of 2.45 v rms. (0 db reference level) as indicated on the ME-26(*)/U or a convenient level if 2.45 v rms cannot be obtained.	

NOTE

The reference level which has now established on the ME-26(*)/U should be maintained. During the remaining steps of the test, the RT-834/GRC or RT-662/GRC MANUAL RF GAIN and AUDIO GAIN controls should be adjusted only if checks indicate the reference level has been disturbed. The output of the AN/GRM-50 should be checked each time the AN/GRM-50 frequency is changed and should be maintained at 150 mv rms.

Table 3-44. Receiver Frequency Response and IF Bandwidth Test—Continued

Step	Operation of test equipment	Control settings and operation of equipment	Performance standard
12	Slowly tune the AN/GRM-50 from 2.000300 MHz to 2.003400 MHz and note the maximum and minimum audio output (not more than 3 db down) as indicated on the ME-26(*)/U relative to the db reference level established in step 11 above; note also the frequencies at which they occur.	-----	See figure 3-62 for frequency response curve limits.
13	Set the AN/GRM-50 to 2.000010 MHz \pm 10 Hz.	-----	Reduce the attenuator setting until the reference level in Step 11 is obtained.
14	Reduce HP-335D attenuator setting at least 40 dB until the reference level established in step 11 is observed.	-----	Reference level same as observed in step 11.
15	Set the AN/GRM-50 to 2.005000 MHz \pm 100 Hz.	-----	It should be necessary to remove at least 40 db of attenuation to re-establish the reference level.
16	Reduce HP-335D attenuator setting at least 40 db until the reference level established in step 11 is obtained.	-----	Reference level same as established in step 11.
17	Disconnect all test cables.		
18	-----	Loosen captive screws on front of RT-834/GRC or RT-662/GRC and slide chassis out of case. Set age/alc switch 1A1S11 to (down position). Fasten RT-834/GRC or RT-662/GRC back in case.	

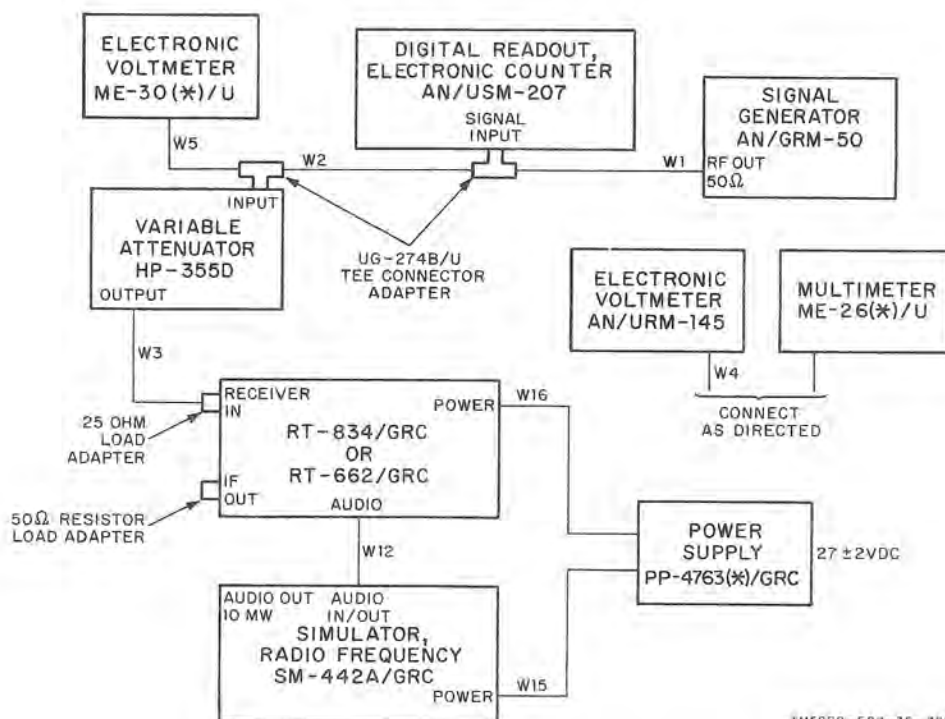

TM5820-520-35-709

Figure 3-61. Receiver frequency response tests, connection diagram.

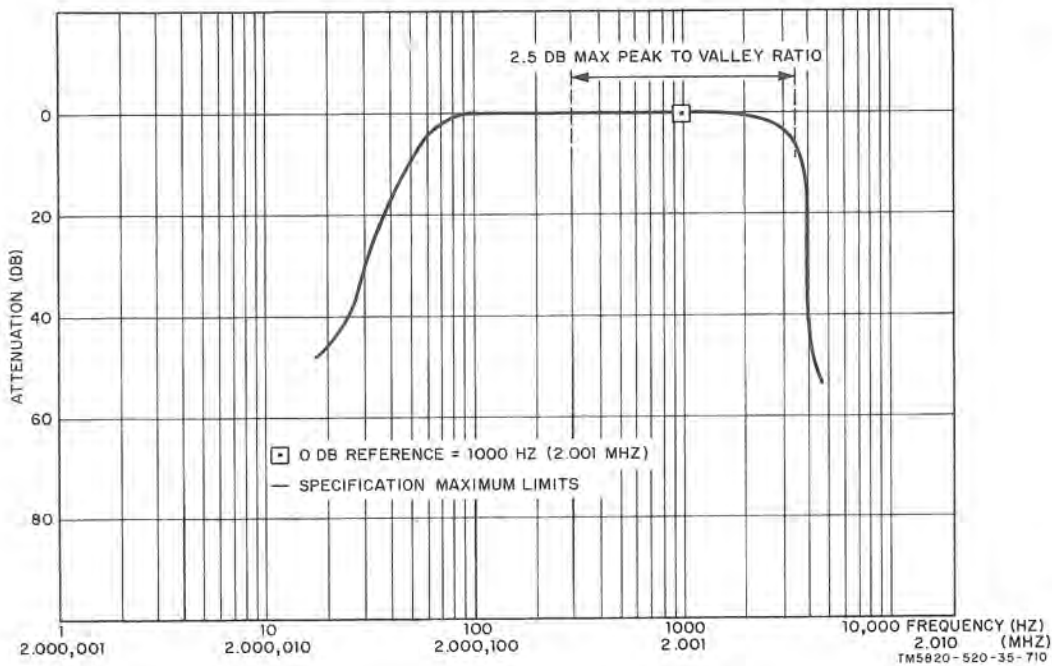

Figure 3-62. Frequency response curve.

Table 3-45. BFO Test

Step	Operation of test equipment	Control settings and operation of equipment	Performance standard
1	Connect equipment as shown in figure 3-63.		
	NOTE If the RT-834/GRC or RT-662/GRC is interconnected with the AM-3349/GRC-106, these connections must be removed before proceeding with the following tests.		
2	Test set preliminary settings: Refer to TM 11-6625-847-12 for preliminary control settings.		
3	Apply power to all equipment. Allow 15 minutes for warmup.		
4	SM-442A/GRC (test set) settings: a. Key switch to ON. b. SERV SEL switch to CW. c. PA-RT switch to RT. d. REC-XMIT switch to XMIT. e. XMIT-STATUS switch to OPERATE.	RT-834/GRC or RT-662/GRC preliminary settings: a. SERVICE SELECTOR switch to CW. b. SQUELCH switch to OFF. c. FREQ VERNIER control to OFF. d. MANUAL RF GAIN control fully clockwise. e. AUDIO GAIN control fully counterclockwise. f. Frequency controls to 02000. g. VOX switch to PUSH TO TALK. h. BFO control fully counterclockwise.	
5	-----	Vary the RT-834/GRC or RT-662/GRC AUDIO GAIN control and observe that the audio output signal (sidetone), as indicated on the ME-30(*)/U varies accordingly.	

Table 3-45. BFO Test—Continued

Step	Operation of test equipment	Control settings and operation of equipment	Performance standard
6	-----	Set RT-834/GRC or RT-662/GRC AUDIO GAIN control for an output of 2.0 v rms as indicated on the ME-30(*)/U.	The frequency of the audio tone should be at least 3,500 Hz but not more than 6,000 Hz, as indicated by the AN/USM-207.
7	-----	Rotate RT-834/GRC or RT-662/GRC BFO control fully clockwise and repeat step 6.	Same as step 6.
8	Set the test set KEY switch alternately to ON and OFF several times and note that the sidetone is present only when the RT-834/GRC or RT-662/GRC is in the keyed condition.		NOTE Observe a zero beat on the ME-30(*)/U when adjusting BFO to clockwise position.
9	Disconnect all test cables.		

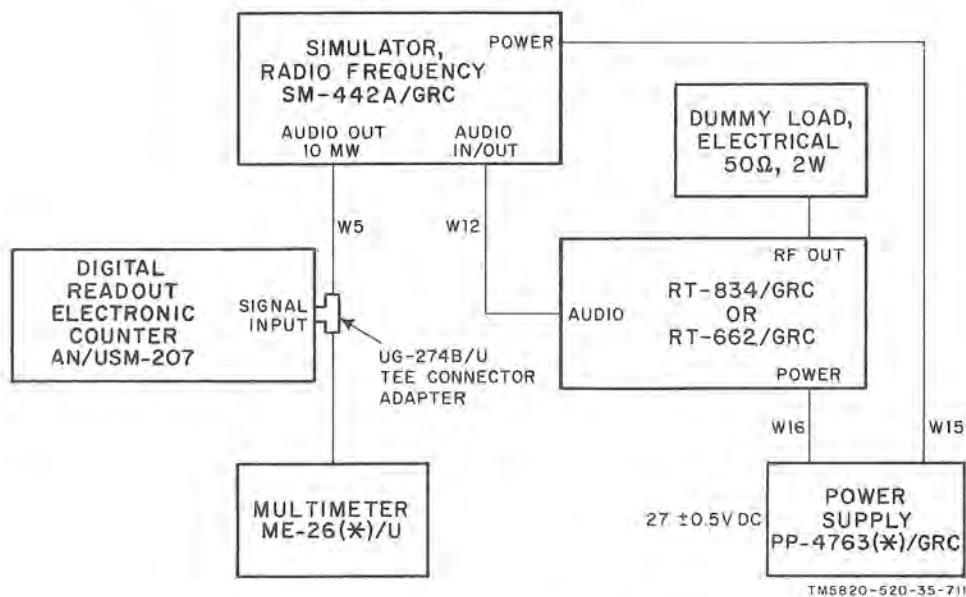

Figure 3-63. BFO test connection diagram.

Table 3-46. Signal Level Meter Test

Step	Operation of test equipment	Control settings and operation of equipment	Performance standard
1	Connect equipment as shown in figure 3-64.		
	NOTE If the RT-834/GRC or RT-662/GRC is interconnected with the AM-3349/GRC-106, these connections must be removed before proceeding with the following tests.		
2	Test set preliminary settings: Refer to TM 11-6625-847-12 for preliminary control settings.		

Table 3-46. Signal Level Meter Test—Continued

Step	Operation of test equipment	Control settings and operation of equipment	Performance standard
3	Apply power to all equipment. Allow 15 minutes for warmup.		
4	SM-442A/GRC (test set) settings: a. KEY switch to OFF. b. SERV SEL switch to SSB/NSK. c. PA-RT switch to RT	RT-834/GRC or RT-662/GRC preliminary settings: a. SERVICE SELECTOR switch to SSB/NSK. b. SQUELCH switch to OFF. c. FREQ VERNIER control to OFF. d. MANUAL RF GAIN control fully clockwise. e. AUDIO GAIN control fully clockwise. f. Frequency controls to 02000. g. VOX switch to PUSH TO TALK.	
5	Adjust CN-764/U for 100 db attenuation.		
6	Set AN/GRM-50 for an unmodulated cw output of 0.5 v rms at 2.001 MHz ±100 Hz as shown by a AN/USM-207 indication of 1,000 Hz.		1,000 Hz ±100.
7		Observe indication on RT-834/GRC or RT-662/GRC signal level meter.	Indication should be between 0 and 20.
8	Set the CN-764/U for 0 dB attenuation and AN/GRM-50 to 1.0 v rms.	Observe RT-834/GRC or RT-662/GRC signal level meter.	Indication should be not less than 75.
9	Key RT-834/GRC or RT-662/GRC by setting test set KEY switch to ON.	Set RT-834/GRC or RT-662/GRC SERVICE SELECTOR switch to CW.	
10		Observe RT-834/GRC or RT-662/GRC signal level meter indication.	Indication should be between 15 and 60.
11	Disconnect all test cables.		

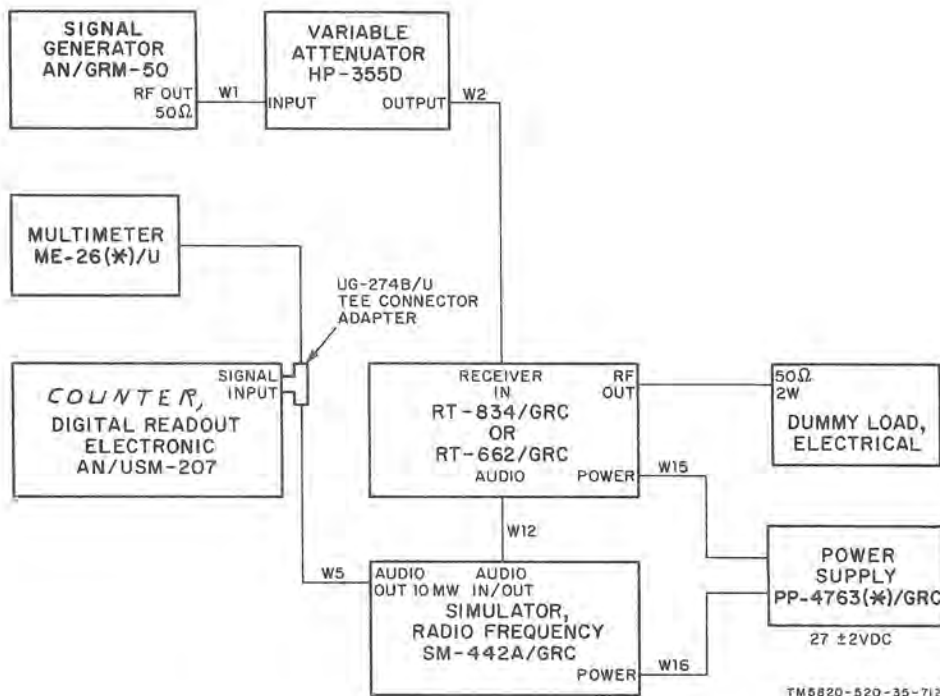

TM 5820-520-35-712

Figure 3-64. Signal level meter tests, connection diagram.

Table 3-47. Antenna Transfer Test

Step	Operation of test equipment	Control settings and operation of equipment	Performance standard
1	Connect equipment as shown in figure 3-65.		
	WARNING		
	Do not connect the CG-409G/C, which supplies the RF drive from the AN/GRM-50 to the AM-3349/GRC-106. If the RF drive cable is connected, RF will be present at the antenna terminals of the AM-3349/GRC-106 during continuity measurements. Serious burns will result from contact with antenna connector.		
2	Test set preliminary settings; Refer to TM 11-6625-847-12 for preliminary control settings.		
3	-----	Preliminary settings for the AM-3349/GRC-106 are as follows: a. TUNE-OPERATE switch to OPERATE. b. TEST METER switch to POWER OUT.	
4	Set SM-442A/GRC (test set) controls as follows: a. SERV SEL switch to SSB/NSK. b. PA-RT switch to PA. c. XMIT-STATUS switch to OPR. d. REC-XMIT switch to XMIT. e. M.C. FREQ control to— 10 MC to 2 1 MC to 9 0.1 MC to 9		
5	Apply power to all equipment. Allow 15 minutes for warmup.		
6	Hold the AM-3349/GRC-106 flag switch to one side and connect TS-352B/U ohms lead to 50 OHM LINE connector and RCVR ANT connector.	-----	TS-352B/U should indicate closed circuit.
7	Disconnect TS-352B/U lead from 50 OHM LINE connector.		
8	Connect TS-352B/U lead to AM-3349/GRC-106 WHIP connector.	-----	TS-352B/U should indicate closed circuit.
9	Remove TS-352B/U lead from WHIP connector and connect it to chassis ground of AM-3349/GRC-106.	-----	TS-352B/U should indicate open circuit.
10	-----	Set the AM-3349/GRC-106 TUNE-OPERATE switch to TUNE.	Indication on AM-3349/GRC-106 TEST METER should be at left index mark. If a meter indication is noted, stop test because this indicates RF power at WHIP antenna connector.

Table 3-47. Antenna Transfer Test—Continued

Step	Operation of test equipment	Control settings and operation of equipment	Performance standard
11	Remove TS-352B/U lead from ground and connect it to AM-3349/GRC-106 WHIP connector.	-----	TS-352B/U should indicate open circuit.
12	-----	Set the AM-3349/GRC-106 TUNE-OPERATE switch to OPERATE.	
13	Disconnect all test cables.		

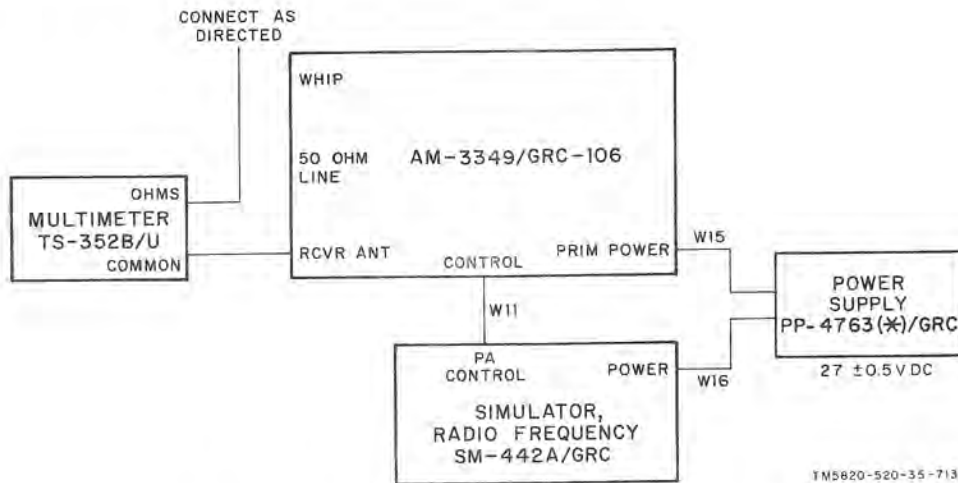

Figure 3-65. Antenna transfer tests, connection diagram.

Table 3-48. High Voltage Reset Circuit Test

Step	Operation of test equipment	Control settings and operation of equipment	Performance standard
1	Connect equipment as shown in figure 3-66.		
2	Test set preliminary settings: Refer to TM 11-6625-847-12 for preliminary control settings.		
3	Apply power to all equipment. Allow 15 minutes for warmup.		
4	Adjust AN/GRM-50 for 29.900 Hz ± 100 Hz, 1.0 v rms.	-----	1.0 v rms at 29.900 MHz, ± 100 Hz.
5	Connect cable between RF signal generator and RF DRIVE connector on the AM-3349/GRC-106.		
6	Set test set controls as follows: <ul style="list-style-type: none"> a. SERV SEL switch to SSB/NSK. b. REC-XMIT switch to XMIT. c. M.C. FREQ control: <ul style="list-style-type: none"> 10 MC to 2 1 MC to 9 d. ----- 	Set ANT TUNE and ANT LOAD to settings on 50 Ω doublet chart.	
7	-----	Set the AM-3349/GRC-106 TUNE-OPERATE switch to TUNE.	

Table 3-48. High Voltage Reset Circuit Test—Continued

Step	Operation of test equipment	Control settings and operation of equipment	Performance standard
8	-----	Adjust the AM-3349/GRC-106 ANT TUNE and ANT LOAD controls for center scale indications on the ANT TUNE and ANT LOAD meters.	
9	-----	Set the AM-3349/GRC-106 TUNE-OPERATE switch to OPERATE.	
10	Slowly increase the AN/GRM-50 output, while observing the AM-3349/GRC-106 TEST METER in PA CUR position.	As the AN/GRM-50 RF output is increased the AM-3349/GRC-106 TEST METER indication should also increase. Before the TEST METER indication passes the triangular dark green area, it will drop to zero, indicating that the high voltage has been interrupted.	
11	Reduce the AN/GRM-50 RF output to 1.0 v rms.		
12	-----	Set the AM-3349/GRC-106 TUNE-OPERATE switch to TUNE and then to OPERATE, to reset the high voltage.	Observe that the TEST METER indicates that current is present.
13	Disconnect all test cables.		

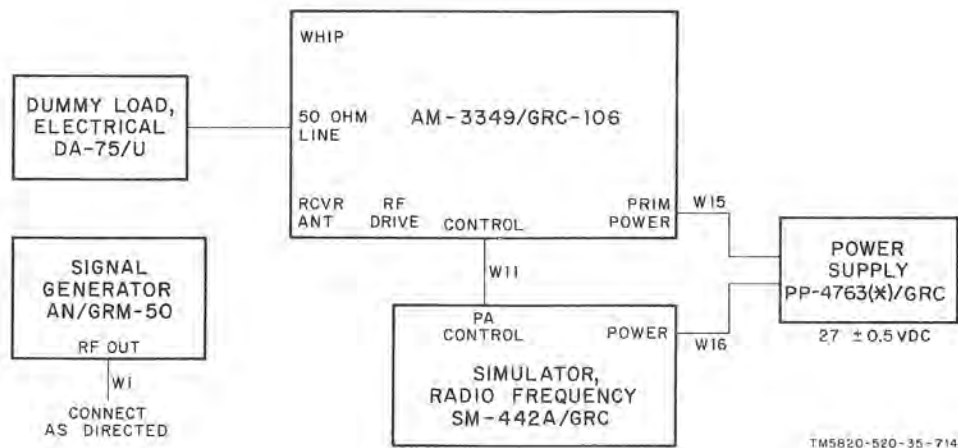

Figure 3-66. High voltage reset circuit tests, connection diagram.

Table 3-49. RT-834/GRC or RT-662/GRC Programming Test

Step	Operation of test equipment	Control settings and operation of equipment	Performance standard
1	Connect cable W15 between the RT-834/GRC or RT-662/GRC POWER connector and the 27 vdc power source, connect cable W16 between SM-442/GRC (test set) POWER connector and the 27 vdc power source.		
2	Plug tray A4 into the test set.		

Table 3-49. RT-834/GRC or RT-662/GRC Programming Test—Continued

Step	Operation of test equipment	Control settings and operation of equipment	Performance standard
3	Test set preliminary settings: Refer to TM 11-6625-847-12 for preliminary settings of the test set and tray A4.		
4	Set test set SERV SEL switch to SSB/NSK.		
5	Set tray A4 switches as follows: a. RF BAND-WHIP-50 Ω at 50 Ω. b. PA-RT to RT.		
6	Connect cable W11 between RT-834/GRC or RT-662/GRC PA CONTROL connector and test set PA CONTROL connector. Connect cable W12 between RT-834/GRC or RT-662/GRC AUDIO connector and test set AUDIO IN-OUT connector.		
7	Operate test set and tray A4 POWER switches to ON.	Operate RT-834/GRC or RT-662/GRC POWER switch to ON.	
8	Perform the remaining steps of the procedure while observing tray A4 CONTROL TEST lamps. For each step, the lamp indicated in the <i>Performance standard</i> column should light.		
NOTE Set the 100 Hz control on the RT-834/GRC to the 0 position for all frequencies required in the following procedure.			
9	-----	Set the RT-834/GRC or RT-662/GRC frequency controls for 02.000 mc. Set the SERVICE SELECTOR switch to STANDBY.	NOTE Disregard dimly lighted lamps. Lamps A-3, A-5, B-1 will light. (C-3 is on all the time.)
10	-----	Slowly set the SERVICE SELECTOR switch to each operating mode.	Lamps A-3, A-5, B-1, B-2, C-1, C-2 will light each position. (C-3 on all the time.)
11	-----	With the SERVICE SELECTOR in any operate mode, set the RT-834/GRC or RT-662/GRC and frequency controls so that the RT turret will tune to each one of its 30 positions. Observe that while the RT-834/GRC or RT-662/GRC is tuning, B3 lights momentarily.	Lamps B-1, B-2, C-2, C-3 will remain lighted during frequency change. Refer to table 3-50 to determine which lights in row A will light for each turret position.
12	Disconnect all test cables.		

Table 3-50. Receiver-Transmitter, Radio RT-834/GRC or RT-662/
GRC Code Sequences

Freq (MHz)	Code line					Turret position	Tray A4 control test lights, row A				
	1	2	3	4	5		1	2	3	4	5
2.0 to 2.5	0	1	0	1	0	1	0	0	1	0	1
3.0 to 3.5	0	0	1	0	1	2	0	1	0	1	0
14 to 15	1	0	0	1	0	3	1	0	0	0	1
15 to 16	1	1	0	0	1	4	1	0	1	1	0
24 to 25	0	1	1	0	0	5	0	1	1	0	0
25 to 26	0	0	1	1	0	6	0	1	0	0	1
16 to 17	0	0	0	1	1	7	0	0	0	1	1
17 to 18	1	0	0	0	1	8	1	0	0	1	0
2.5 to 3.0	0	1	0	0	0	9	0	0	1	0	0
3.5 to 4.0	0	0	1	0	0	10	0	1	0	0	0
18 to 19	0	0	0	1	0	11	0	0	0	0	1
19 to 20	0	0	0	0	1	12	0	0	0	1	0
26 to 27	1	0	0	0	0	13	1	1	1	0	0
27 to 28	1	1	0	0	0	14	1	1	1	0	0
28 to 29	1	1	1	0	0	15	1	1	1	0	0
29 to 30	1	1	1	1	0	16	1	1	1	0	1
20 to 21	0	1	1	1	1	17	0	1	1	1	1
21 to 22	1	0	1	1	1	18	1	1	0	1	1
22 to 23	1	1	0	1	1	19	1	0	1	1	1
23 to 24	0	1	1	0	1	20	0	1	1	1	0
4 to 5	1	0	1	1	0	21	1	1	0	0	1
5 to 6	0	1	0	1	1	22	0	0	1	1	1
8 to 9	1	0	1	0	1	23	1	1	0	1	0
9 to 10	1	1	0	1	0	24	1	0	1	0	1
6 to 7	1	1	1	0	1	25	1	1	1	1	0
7 to 8	0	1	1	1	0	26	0	1	1	0	1
12 to 13	0	0	1	1	1	27	0	1	0	1	1
13 to 14	1	0	0	1	1	28	1	0	0	1	1
10 to 11	0	1	0	0	1	29	0	0	1	1	0
11 to 12	1	0	1	0	0	30	1	1	0	0	0

1 Represents grounded code line, lighted test lamp.
0 Represents open (ungrounded) code line, test lamp not lighted.

Table 3-51. AM-3349/GRC-106 Code Inputs to Antenna Coupler Assembly 2A3
Test

Step	Operation of test equipment	Control settings and operation of equipment	Performance standard
1	-----	Remove the AM-3349/GRC-106 from its case.	
2	-----	Remove the antenna coupler assembly 2A3 from the AM-3349/GRC-106 main chassis (para 2-19).	
3	Connect the equipment as shown in figure 3-67.		
4	Test set preliminary settings: Connect tray A4 to the SM-442A/GRC (test set) then refer to TM 11-6625-847-12 for preliminary control settings.		
5	-----	Set the AM-3349/GRC-106 controls as follows: PRIM PWR switch: OFF. TUNE-OPERATE switch: TUNE. TEST METER switch: PRIM VOLT.	

Table 3-51. AM-3349/GRC-106 Code Inputs to Antenna Coupler
 Assembly 2A3 Test—Continued

Step	Operation of test equipment	Control settings and operation of equipment	Performance standard
6	Set the test set M.C. FREQ 10 MC switch to 0, 1 M switch to 2, and 1 MC switch to 0.		
7	Set the test set SERV SEL switch to SSB/NSK, PA-RT switch to PA, and POWER switch to ON.		
8	-----	Set the AM-3349/GRC-106 PRIM PWR switch to ON.	
9	Set tray A4 POWER switch to ON, RF BAND- 50 Ω WHIP switch to RF BAND, and ANT MOTOR CONTROL MONITOR switch to RF BAND.		CONTROL TEST lamps A-1, B-3, B-5 will light. C-3 will remain on all during the test.
10	Press and hold tray A4 ANT MOTOR CONTROL CODE switch in the RF BAND position.		Lamps A-1, B-3 will remain lighted, B-5 will go out, and C-1 light. Lamps A-1, B-3 will remain lighted, C-1 will go out, and B-5 will light.
11	Release tray A4 ANT. MOTOR CONTROL CODE switch.		
12	Set tray A4 ANT. MOTOR CONTROL MONITOR switch to CAP.	-----	Lamps A-1, B-3 and B-5 will remain lighted.
13	Press and hold tray A4 ANT. MOTOR CONTROL CODE switch in the CAP position.	-----	Lamps A-1, B-3, will remain lighted, B-5 will go out, and C-1 will light.
14	Release tray A4 ANT. MOTOR CONTROL CODE switch.	-----	Lamps A-1, B-3 will remain lighted, C-1 will go out, and B-5 will light.
15	Refer to table 3-52, and set the test set M.C. FREQ controls, and tray A4 RF BAND- 50 Ω-WHIP switch to each indicated position to check frequency coding. Disregard all lamp indications other than A-1 through A-5, and B-1 through B-4.	-----	Lamps A-1 through A-5, and B-1, B-2, and B-4 will light in different combinations, as indicated on the chart. B-3 and B-5 will remain lighted throughout the test.

NOTE

When checking 50-ohm coding of the AM-3349/GRC-106, use a spare cable or connector to hold the flag switch over the AM-3349/GRC-106 50 OHM LINE connector in the proper position for 50-ohm line operation.

- | | | | |
|----|-----------------------------|--|--|
| 16 | Disconnect all test cables. | | |
| 17 | ----- | Replace antenna coupler assembly 2A3 in the AM-3349/GRC-106 chassis; then replace chassis in case. | |

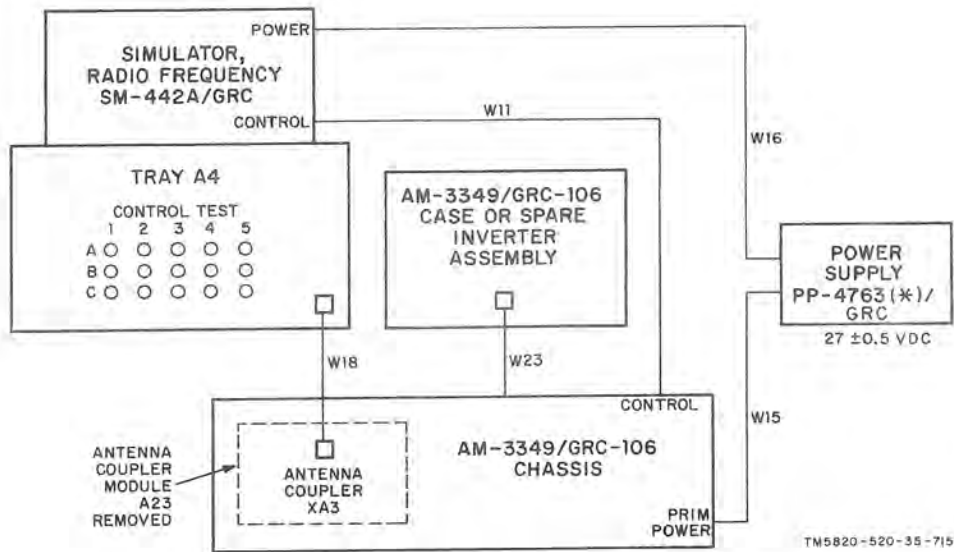

Figure 3-67. Testing of Amplifier Radio Frequency AM-3349/GRC-106 code inputs to antenna coupler assembly, connection diagram.

Table 3-52. AM-3349/GRC-106 Coding Sequence Test

Tray A4 CONTROL TEST switch position	Test set MHz FREQ switch position			Equivalent frequency (MHz).	Tray A4 CONTROL TEST lamps (X indicates lamp is lighted)										
	10 MC	1 MC	0.1 MC		A-1	A-2	A-3	A-4	A-5	B-1	B-2	B-4			
RF BAND	0	2	0	02.0	X										
	0	2	5	02.5	--	X									
	0	3	0	03.0	--	--	X								
	0	3	5	03.5	--	--	--	X							
	0	4	0	04.0	--	--	--	--	X	--	X				
	1	0	0	10.0	--	--	--	--	--	X	--	X			
	2	2	0	22.0	--	--	--	--	X	--	X				
	2	7	0	27.0	--	--	--	--	--	X	--	X			
WHIP	1	0	0	10.0	X	--	--	--	--	--	--	--	X		
	1	1	0	11.0	--	X	--	--	--	--	--	--	X		
	1	2	0	12.0	--	--	X	--	--	--	--	--	X		
	1	4	0	14.0	--	--	--	X	--	--	X	X			
	1	5	0	15.0	--	--	--	--	X	--	--	X			
	2	2	0	22.0											
	2	7	0	27.0	--	--	--	X	--	--	X	X			
	2	8	0	28.0	--	--	--	X	--	--	X	X			
	2	9	0	29.0	--	--	--	X	--	--	X	X			
	2	9	5	29.5	--	--	--	X	--	--	X	X			
	50 (Ω)	0	2	0	02.0	X	--	--	--	--	--	--	--	X	
		0	5	0	05.0	--	X	--	--	--	--	--	--	X	
0		7	0	07.0	--	--	X	--	--	--	--	--	X		
1		2	0	12.0	--	--	--	X	--	--	--	--	X		
1		4	0	14.0	--	--	--	--	X	--	--	--	X		
1		9	0	19.0	--	--	--	--	--	X	--	--	X		
2		4	0	24.0	--	--	--	--	--	--	X	X			
2		9	5	29.5	--	--	--	--	--	--	X	X			

Table 3-53. AM-3349/GRC-106 Front Panel Assembly Tests

Step	Operation of test equipment	Control settings and operation of equipment	Performance standard
1	-----	Remove front panel from AM-3349/ GRC-106.	
2	Connect equipment as shown in figure 3-68.		
3	For preliminary control set- tings on the test set and tray A4, refer to TM 11-6625- 847-12.		
4	-----	AM-3349/GRC-106 preliminary settings: a. PRIM PWR switch: OFF. b. TUNE-OPERATE switch: OPERATE. c. TEST METER switch: DRIVER CUR.	
5	Test set settings: a. REC-XMIT switch to XMIT. b. SERV SEL switch to SSB/ NSK. c. ALL M.C. FREQ. switches to 0.		
<p style="text-align: center;">NOTE</p> <p>All tray A4 control panel designations used throughout these front panel assembly tests refer to the PA METER TEST section unless otherwise specified.</p>			
6	Apply power to test equip- ment.		
7	Meter tests:		
	a. Connect oscilloscope to tray A4 ALC METER test points and observe in- dication.	----- 0 vdc.	
	b. Adjust tray A4 ALC ME- TER control to obtain center scale indication on AM-3349/GRC-106 TEST METER. Observe oscilloscope deflection.	----- +108 ±21 mv dc.	
	c. Set tray A4 ALC METER control fully counter- clockwise.		
	d. -----	Set AM-3349/GRC-106 TEST ME- TER switch to POWER OUT.	
	e. Adjust tray A4 ALC ME- TER control to obtain center scale indication on AM-3349/GRC-106 TEST METER. Observe AN/USM-281A de- flection.	----- +108 ±21 mv dc.	
	f. Set tray A4 ALC METER control fully counter- clockwise.		
	g. Disconnect AN/USM-281A and connect it to tray A4 grid drive test points.		

Table 3-53. AM-3349/GRC-106 Front Panel Assembly Tests—Continued

Step	Operation of test equipment	Control settings and operation of equipment	Performance standard
h.	-----	Set AM-3349/GRC-106 TEST METER switch to GRID DRIVE.	-----
i.	Adjust tray A4 GRID DRIVE control to obtain center scale indication on AM-3349/GRC-106 TEST METER. Observe AN/USM-281A deflection.	-----	15 +3 -0 vdc.
j.	Set tray A4 GRID DRIVE control fully counter-clockwise.	-----	-----
k.	Disconnect AN/USM-281A.	-----	-----
l.	Connect AN/USM-281A to tray A4 antenna load/tune test points.	-----	-----
m.	-----	Set AM-3349/GRC-106 TUNE-OPERATE switch to TUNE.	-----
n.	Set ANT LOAD-ANT TUNE switch to ANT TUNE. Adjust tray A4 ANTENNA LOAD-TUNE control so that AM-3349/GRC-106 ANT TUNE meter indicator is at extreme right end of red bar to the right. Observe AN/USM-281A deflection.	-----	108 ± 21 mv dc.
o.	Adjust tray A4 ANTENNA LOAD-TUNE control so that AM-3349/GRC-106 ANT TUNE meter indicator is at extreme left end of red bar to the left. Observe AN/USM-281A deflection.	-----	108 ± 21 mv dc.
p.	-----	Set AM-3349/GRC-106 TUNE-OPERATE switch to OPERATE.	-----
q.	Adjust tray A4 ANTENNA LOAD-TUNE control so that AM-3349/GRC-106 ANT TUNE meter indicator is at start of red bar to the right. Observe AN/USM-281A deflection.	-----	+1.5 ± 0.3 vdc.
r.	Adjust tray A4 ANTENNA LOAD-TUNE control so that AM-3349/GRC-106 ANT TUNE meter indicator is at start of red bar to the left. Observe AN/USM-281A deflection.	-----	-1.5 ± 0.3 vdc.
s.	Adjust tray A4 ANTENNA LOAD-TUNE control so that AM-3349/GRC-106 ANT TUNE meter indicator is at center scale.	-----	-----
t.	Set Tray A4 ANT LOAD-TUNE switch to ANT LOAD.	-----	-----
u.	-----	Set AM-3349/GRC-106 TUNE-OPERATE switch to TUNE.	-----

Table 3-53. AM-3349/GRC-106 Front Panel Assembly Tests—Continued

Step	Operation of test equipment	Control settings and operation of equipment	Performance standard
v.	Adjust tray A4 ANTENNA LOAD-TUNE control so that AM-3349/GRC-106 ANT LOAD meter indicator is at extreme right end of red bar to the right. Observe AN/USM-281A deflection.	-----	+108 ± 21 mv dc.
w.	Adjust tray A4 ANTENNA LOAD-TUNE control so that AM-3349/GRC-106 ANT LOAD meter indicator is at extreme left end of red bar to the left. Observe AN/USM-281A deflection.	-----	-108 ± 21 mv dc.
x.	-----	Set AM-3349/GRC-106 TUNE-OPERATE switch to OPERATE.	
y.	Adjust tray A4 ANTENNA LOAD-TUNE control so that AM-3349/GRC-106 ANT LOAD meter indicator is at start of red bar to the right. Observe AN/USM-281A deflection.	-----	+462 ± 96 mv dc.
z.	Adjust tray A4 ANTENNA LOAD-TUNE control so that AM-3349/GRC-106 ANT LOAD meter indicator is at start of red bar to the left. Observe AN/USM-281A deflection.	-----	-482 ± 96 mv dc.
aa.	Disconnect AN/USM-281A.		
ab.	Adjust tray A4 ANTENNA LOAD-TUNE control so that AM-3349/GRC-106 ANT LOAD meter indicator is at center scale.		
8	Continuity tests:		
	CAUTION		
	Controls must be operated in the sequence given to prevent equipment damage.		
a.	Confirm operation of all tray A4 indicator lamps by pressing each one to test for lighting.		
b.	-----	Check to see that AM-3349/GRC-106 TUNE-OPERATE switch is at OPERATE.	
c.	Set test set REC-XMIT switch to REC.		
d.	Set tray A4 RF BAND-50 Ω WHIP switch to 50 Ω and observe lighted lamps.	-----	Lamps B1, B3, C1, C3 and C5 will light.
e.	Set test set REC-XMIT switch to XMIT. Observe lighted lamps.	-----	Lamps B1, B2, C3 and C5 will light.

Table 3-53. AM-3349/GRC-106 Front Panel Assembly Tests—Continued

Step	Operation of test equipment	Control settings and operation of equipment	Performance standard
f.	-----	Set AM-3349/GRC-106 TUNE-OPERATE switch to TUNE. Observe lighted lamps.	Lamps B1, B3, B5, C3 and C4 will light.
g.	-----	Push AM-3349/GRC-106 50 OHM LINE flag counterclockwise and hold.	
h.	-----	Set AM-3349/GRC-106 TUNE-OPERATE switch to OPERATE.	Lamps B2, B3, B5, C3 and C5 will light.
i.	-----	Release AM-3349/GRC-106 50 OHM LINE flag.	
i.	-----	Set AM-3349/GRC-106 TUNE-OPERATE switch to TUNE.	
k.	Set test set REC-XMIT switch to REC.		
l.	Rotate test set 1 MC FREQ switch from 0 to 9, while observing lamp B4.	-----	Lamp lights between switch settings.
m.	Set test set 1 MC FREQ switch to 0. Observe that lamps A1 through A5 are not lighted.		
n.	Check the 5-line code by observing lamps A1 through A5 for the various positions of the test set M.C. FREQ switches. Switch positions and the corresponding lamp sequences are given in table 3-54. (Disregard all lamps other than A1 through A5 when performing these tests.)	-----	See table 3-54.
9	Continuity checks:		
a.	-----	Check to see that AM-3349/GRC-106 PRIM PWR switch is at OFF.	
b.	-----	Set AM-3349/GRC-106 TEST METER switch to PRIM VOLT.	
c.	On test set, check to see that the 500 V LOAD is at low, 2400 VOLT LOAD switch is at 1, and REC-XMIT switch is at REC.		
d.	Connect AN/USM-281A between 2A5A2T1-3 and ground. See figure 2-33 for location.		
e.	Turn on blower and direct output to the 2A5A2Q2 heat sink.		
f.	-----	Connect 27 vdc power source to PRIM POWER connector on AM-3349/GRC-106 front panel.	
g.	Turn on 27 vdc power source and adjust for 27 vdc.		
h.	-----	Set the AM-3349/GRC-106 PRIM PWR switch to ON, and the TUNE-OPERATE switch to TUNE. Reset by switching to OPERATE and then back to TUNE if it is necessary.	

Table 3-53. AM-3349/GRC-106 Front Panel Assembly Tests—Continued

Step	Operation of test equipment	Control settings and operation of equipment	Performance standard
i.	Observe ammeter indication on 27 vdc power source.	-----	Approximately 12 amp. Observe that lamp C2 on tray A4 is lighted.
j.	Connect TS-352B/U between PRIM V test point on the AM-3349/GRC-106 and ground. See figure 2-31 for location of test point.	-----	27 ± 1 vdc.
k.	-----	Observe AM-3349/GRC-106 TEST METER indication.	Pointer should indicate in the dark green portion of scale.
l.	-----	Set AM-3349/GRC-106 TEST METER switch to LOW VOLT.	
m.	-----	Observe AM-3349/GRC-106 TEST METER indication.	Pointer should indicate in dark green portion of scale.
n.	Connect TS-352B/U between LV test point on the AM-3349/GRC-106 and ground. See figure 2-31 for location of test point.	-----	+525 ± 25 vdc.
o.	Set test set 500 V LOAD switch to HIGH. Observe TS-352B/U indication.	-----	+525 ± 25 vdc.
p.	Set test set 500 V LOAD switch to LOW.	-----	
q.	-----	Set AM-3349/GRC-106 TEST METER switch to HIGH VOLT.	
r.	-----	Observe AM-3349/GRC-106 TEST METER indication.	Pointer should indicate in dark green portion of scale.
s.	Connect TS-352B/U between HV test point on the AM-3349/GRC-106 and ground. See figure 2-31 for location of test point.	-----	+22.8 to +25.2 vdc.
t.	-----	Set AM-3349/GRC-106 TUNE-OPERATE switch to OPERATE.	
u.	Depress lamp C1 on tray A4 to disable high voltage circuitry.	-----	TS-352B/U indicates 0 volt. AN/USM-281A waveform disappears.
v.	Set the test set REC-XMIT switch to XMIT, and observe TS-352B/U and AN/USM-281A indications.	-----	TS-352B/U: +22.8 to +25.2 vdc. AN/USM-281A: Period: 0.88 ± 22 ms. Risettime: ≤ 30 μsec. Falltime: ≤ 30 sec.
w.	Rotate test set 2400 VDC LOAD switch from positions 1 through 8.	-----	At position 7, the AN/USM-281A waveform will disappear.
x.	Set test set 2400 VDC LOAD switch to position 1.	-----	
y.	-----	Reset high voltage on AM-3349/GRC-106 by setting the TUNE-OPERATE switch to TUNE and back to OPERATE.	AN/USM-281A waveform should reappear.
z.	-----	Set AM-3349/GRC-106 TEST METER switch to PA CUR.	
aa.	-----	Press and hold AM-3349/GRC-106 PA IDLE CUR switch (S1), and observe TEST METER indication.	TEST METER will show full-scale deflection to the right.

Table 3-53. AM-3349/GRC-106 Front Panel Assembly Tests—Continued

Step	Operation of test equipment	Control settings and operation of equipment	Performance standard
ab.	-----	Release AM-3349/GRC-106 PA IDLE CUR switch.	10 to 12 vdc.
ac.	Connect TS-352B/U between 2A5A3E1 and ground.	-----	10 to 12 vdc.
ad.	Turn off power source to AM-3349/GRC-106 front panel. Leave test set power on and set test set REC-XMIT switch to XMIT.	-----	
ae.	Connect TS-352B/U between the normally open contact of 2A5K1 (rear contact) and the WHIP connector on AM-3349/GRC-106. See figure 2-33 for location of relay.	-----	Less than 1 ohm.
af.	Connect TS-352B/U between the normally open contact of 2A5K1 (rear contact) and the 50 OHM LINE connector (hold back flag switch) on AM-3349/GRC-106.	-----	Less than 1 ohm.
ag.	Release flag switch connect TS-352B/U between AM-3349/GRC-106 RCVR ANT and WHIP connectors.	-----	Greater than 1 megohm.
ah.	Connect TS-352B/U between AM-3349/GRC-106 front panel ground and the following connectors: RF DRIVE RCVR ANT 50 OHM LINE WHIP	-----	Greater than 1 megohm.
ai.	Set test set REC-XMIT to REC.	-----	
aj.	Connect TS-352B/U between AM-3349/GRC-106 RCVR ANT and WHIP connectors.	-----	Less than 1 ohm.
ak.	-----	Set AM-3349/GRC-106 PRIM PWR switch to OFF.	
al.	Turn off power source to AM-3349/GRC-106 (if separate).	-----	
am.	Turn blower off.	-----	
an.	Set test set SERV SEL and PRIM POWER switches to OFF.	-----	
ao.	Set tray A4 Power switch to OFF.	-----	
ap.	Disconnect all test equipment and cables from the AM-3349/GRC-106 front panel.	-----	

Table 3-53. AM-3349/GRC-106 Front Panel Assembly Tests—Continued

Step	Operation of test equipment	Control settings and operation of equipment	Performance standard
NOTE			
Refer to figures 2-31 and 2-33 for location of test points called out in the following tapes.			
aq.	Connect TS-352B/U between AM-3349/GRC-106 test point J1-A1 and RF DRIVE connector.	-----	Less than 1 ohm.
ar.	Connect TS-352B/U between AM-3349/GRC-106 test point J1-26 and the front panel casting.	-----	Less than 1 ohm.
as.	Connect TS-352B/U between AM-3349/GRC-106 50 OHM LINE and RCVR ANT connectors.	-----	Less than 1 ohm.
at.	Connect positive end of TS-352B/U to AM-3349/GRC-106 test point A2K1-4 and the negative end to test point A2K1-2.	-----	Greater than 100K ohms.
au.	Reverse TS-352B/U leads, connecting positive end to A2K1-2 and negative end to A2K1-4.	-----	Less than 200 ohm.
av.	Disconnect all test cables.	-----	

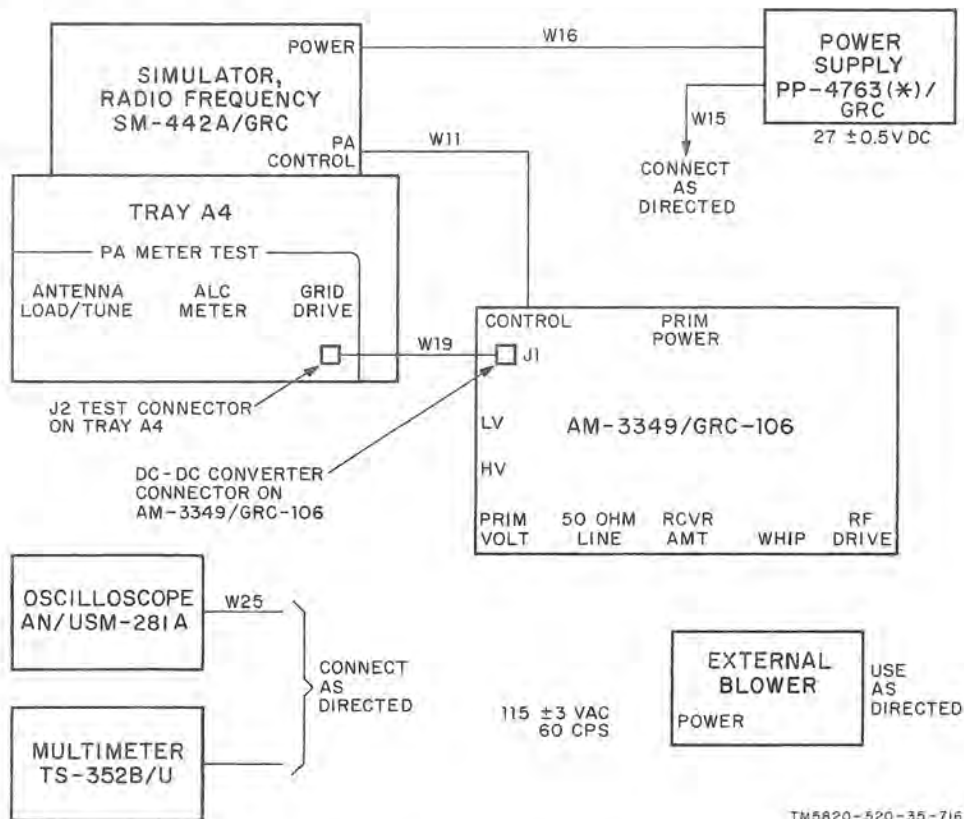

TM5820-520-35-716

Figure 3-68. Amplifier Radio Frequency AM-3349/GRC-106 front panel assembly tests, connection diagram.

Table 3-54. Switch Position and Lamp Sequence for Code Line Check

MHz FREQ switch positions			Equivalent freq (in MHz)	Illuminated lamps				
1 MHz	1 MHz	10 MHz		A1	A2	A3	A4	A5
0	0	0	2.0	--	X	--	X	
5	2	0	2.5	--	X			
0	3	0	3.0	--	--	X	--	X
5	3	0	3.5	--	--	X		
0	4	0	4.0	X	--	X	X	
0	5	0	5.0	--	X	--	X	X
0	6	0	6.0	X	X	X	--	X
0	7	0	7.0	--	X	X	X	
0	8	0	8.0	X	--	X	--	X
0	9	0	9.0	X	X	--	X	
0	0	1	10.0	--	X	--	--	X
0	1	1	11.0	X	--	X		
0	2	1	12.0	--	--	X	X	X
0	3	1	13.0	X	--	--	X	X
0	4	1	14.0	X	--	--	X	
0	5	1	15.0	X	X	--	--	X
0	6	1	16.0	--	--	--	X	X
0	7	1	17.0	X	--	--	--	X
0	8	1	18.0	--	--	--	X	
0	9	1	19.0	--	--	--	--	X
0	0	2	20.0	--	X	X	X	X
0	1	2	21.0	X	--	X	X	X
0	2	2	22.0	X	X	--	X	X
0	3	2	23.0	--	X	X	--	X
0	4	2	24.0	--	X	X		
0	5	2	25.0	--	--	X	X	
0	6	2	26.0	X				
0	7	2	27.0	X	X			
0	8	2	28.0	X	X	X		
0	9	2	29.0	X	X	X	X	

Table 3-55. System Performance Test

Step	Operation of test equipment	Control settings and operation of equipment	Performance standard
1	Connect equipment as shown in figure 3-69.		
2	Fabricate audio combining network as shown in figure 3-70.		
3	Test Set preliminary settings: Refer to TM 11-6625-847-12 for preliminary control settings.		
4	Apply power to all equipment. Allow 1 hour warmup time.		
5	-----	RT-834/GRC or RT-662/GRC preliminary settings: a. SERVICE SELECTOR switch to FSK. b. SQUELCH switch to OFF. c. FREQ VERNIER control to OFF. d. MANUAL RF GAIN control to fully clockwise. e. AUDIO GAIN control fully counterclockwise. f. For RT-834/GRC set MHz, kHz, and 100 Hz controls to 028300. For RT-662/GRC set MHz and kHz controls to 02830. g. VOX switch to PUSH TO TALK.	

Table 3-55. System Performance Test—Continued

Step	Operation of test equipment	Control settings and operation of equipment	Performance standard
6	-----	AM-3349/GRC-106 preliminary settings: a. PRIM PWR circuit breaker to ON. b. TUNE-OPERATE switch to OPERATE. c. ANT TUNE and ANT LOAD controls to preset numbers for 2,830 MHz, as indicated on the 50-ohm doublet antenna chart on front panel. d. Adjust dc supply to 27 Vdc.	
7	-----	On the AM-3349/GRC-106: a. Set TUNE-OPERATE switch to TUNE. b. Adjust ANT TUNE and ANT LOAD controls for center scale indication on their respective meters. c. Set TEST METER switch to PRIM VOLT and observe TEST METER. d. Set TEST METER switch to LOW VOLT and observe TEST METER. e. Set TEST METER switch to HIGH VOLT and observe TEST METER.	Indication should be within square dark green area. Indication should be within square dark green area. Indication should be within square dark green area.
8	Insert ME-26(*)/U ac probe (tip removed) into HP-11042A tee connector and observe indication.	-----	60 ± 7 v rms.
9	Connect ME-30(*)/U input, using cable W9, to the AUDIO IN 600 Ω input on the test set.	Set AM-3349/GRC-106 TUNE-OPERATE switch to OPERATE.	
10	Two AN/URM-127 No. 1 and No. 2 are used in the test setup. Connect cable W8 from AN/URM-127 No. 1 to the test set AUDIO IN 600 Ω connector. Adjust AN/URM-127 No. 1 for a 1,500 Hz output at 200 mv rms as indicated on the ME-30(*)/U.		
11	Key the RT-834/GRC or RT-662/GRC by setting the test set KEY switch to ON. Observe the ME-26(*)/U sampling the RF output.	-----	103 ± 9 v rms.
12	Set the test set KEY switch to OFF.		
13	Adjust output level of AN/URM-127 (No. 1 at 1,500 Hz, 200 mv, and No. 2 at 2,500 Hz, 200 mv) to 200 mv/tone.		
14	Key the RT-834/GRC or RT-662/GRC by setting the test set KEY switch to ON. observe ME-26(*)/U sampling the RF output.	-----	160 ± 9 v rms.

Table 3-55. System Performance Test—Continued

Step	Operation of test equipment	Control settings and operation of equipment	Performance standard
15	Set the test set KEY switch to OFF.		
16	-----	Set RT-834/GRC or RT-662/GRC SERVICE SELECTOR switch to SSB/NSK.	
17	Key RT-834/GRC or RT-662/GRC by setting the test set KEY switch to ON. (Both AN/URM-127 are still connected for a two-tone input.) Observe the ME-26(*)/U sampling the RF output.	-----	141 +46 -24 v rms.
18	Set test set KEY switch to OFF. Disconnect cable from the AUDIO IN 600Ω connector.	Set RT-834/GRC or RT-662/GRC SERVICE SELECTOR switch to AM.	
19	Key RT-834/GRC or RT-662/GRC by setting the test set KEY switch to ON. Observe the ME-26(*)/U sampling the RF output.	-----	59 +18 -3 v rms.
20	Set the test set KEY switch to OFF.	Set RT-834/GRC or RT-662/GRC SERVICE SELECTOR switch to CW.	
21	Key RT-834/GRC or RT-662/GRC by setting the test set KEY switch to ON. Observe the ME-26(*)/U sampling the RF output.	-----	100 +35 -14 v rms.
22	Set the test set KEY switch to OFF.		
23	-----	Set RT-834/GRC or RT-662/GRC SERVICE SELECTOR switch to FSK and set MHz and kHz controls to 02000.	
24	-----	Set AM-3349/GRC-106 ANT TUNE and ANT LOAD controls to preset numbers for 2,000 MHz, as indicated on 50-ohm doublet antenna chart on front panel.	
25	-----	Set AM-3349/GRC-106 TUNE OPERATE switch to TUNE and adjust ANT TUNE and ANT LOAD controls for center scale indications on their respective meters.	
26	-----	Set AM-3349/GRC-106 TUNE-OPERATE switch to OPERATE.	
27	Connect output of combining network to the test set AUDIO IN 600 Ω connector.		
28	Set test set KEY switch to OFF.		
29	Set test set KEY switch to ON. Observe ME-26(*)/U indication.	-----	141 +46 -24 v rms.
30	-----	Set AM-3349/GRC-106 TEST METER switch to DRIVER CUR and observe indication on TEST METER.	Indication should be within dark green rectangle at center of meter scale.

Table 3-55. System Performance Test—Continued

Step	Operation of test equipment	Control settings and operation of equipment	Performance standard
31	-----	Set AM-3349/GRC-106 TEST METER switch to each of the following positions in turn and note the TEST METER indication: GRID DRIVE----- PA CUR----- POWER OUT-----	Indication should be within light green square to left center of TEST METER scale. Indication should be left of center area bounded by dark green. Area bounded by dark green. Rectangles to the right and left of center.
32	Set test set KEY switch to OFF and disconnect test cables from AUDIO IN 600 Ω connector.	Set RT-834/GRC or RT-662/GRC SERVICE SELECTOR switch to AM.	
33	Key RT-834/GRC or RT-662/GRC by setting test set KEY switch to ON. Observe ME-26(*)/U indication.	-----	+18 59 v rms. -8
34	Set test set KEY switch to OFF.	Set RT-834/GRC or RT-662/GRC SERVICE SELECTOR switch to CW.	
35	Key RT-834/GRC or RT-662/GRC by setting test set KEY switch to ON. Observe ME-26(*)/U indication.	-----	100 ±35 -14 v rms.
36	Set test set KEY switch to OFF.		
37	Repeat steps 26 through 41 above for each frequency listed below:		

NOTE

For each of the following frequencies the 100 Hz control on RT-834/GRC remains in the 0 position.

- 2.000 MHz_ 15.000 MHz
- 2.830_-----16.000
- 3.111_-----17.200
- 3.830_-----18.300
- 4.222_-----19.500
- 5.333_-----20.600
- 6.444_-----21.888
- 7.555_-----22.000
- 8.666_-----23.000
- 9.000_-----24.900
- 10.777_-----25.000
- 11.400_-----26.000
- 12.700_-----27.000
- 13.100_-----28.009
- 14.800_-----29.990

38	-----	Set RT-834/GRC or RT-662/GRC SERVICE SELECTOR switch to SSB/NSK and set MHz and kHz controls to 02000.	
39	-----	Set AM-3349/GRC-106 TUNE-OPERATE switch to TUNE and adjust ANT TUNE and ANT LOAD controls simultaneously for center scale indications on their respective meters. Return TUNE-OPERATE switch to OPERATE.	

Table 3-55. System Performance Test—Continued

Step	Operation of test equipment	Control settings and operation of equipment	Performance standard
40	Following the procedure used in steps 13 through 16, set each AN/URM-127 output to 200 mv. After both AN/URM-127 are adjusted for 200 mv rms output, connect output of network to the test set AUDIO IN 600 Ω input, for a two-tone input. The two AN/URM-127 are still set for frequencies of 1,500 and 2,500 Hz respectively).		
41	Disconnect the ME-30(*)/U from the HP-11042A tee connector.		
42,	Connect adapter 100:1 to variable attenuator input cable W3 and to tee connector HP-11042A.		
43	-----	Set AM-3349/GRC-106 TUNE-OPERATE switch to TUNE.	
44	Use spectrum analysis part of AN/USM-306 to tune the suppressed carrier to the center 7 kHz band width of the AN/USM-281A display.		
45	-----	Set AM-3349/GRC-106 TUNE-OPERATE switch to OPERATE.	
46	Use the external variable attenuator and the AN/USM-281A attenuation controls to reduce the amplitude of the two tones until they extend to the 0 line on the spectrum display.		
47	Adjust attenuators and AN/USM-281A controls to allow the dB amplitude measurement of signal spikes appearing on the AN/USM-281A display. Note the level of the intermodulation spikes on the display. The intermodulation spikes should be at least 30 dB from the tone peaks which were set at the 0 line in step 46. See figure 3-71.		
48	Note level of suppressed carrier seen at the centerline on the spectrum display. The suppressed carrier should be at least 50 dB down from the tone peaks (fig. 3-71).		
49	Note level of opposite sideband spikes. The opposite sideband spikes should be at least 50 dB down from the tone peaks.		

Table 3-55. System Performance Test—Continued

Step	Operation of test equipment	Control settings and operation of equipment	Performance standard																														
50	Set the analyzing test equipment and the AN/GRC-106(*) system at each frequency listed below, and repeat steps 39 through 49.																																
NOTE																																	
For each of the following frequencies the 100 Hz control on the RT-834/GRC remains in the 0 position.																																	
<table border="0"> <tr><td>2.000 MHz</td><td>15.000 MHz</td></tr> <tr><td>2.830</td><td>16.000</td></tr> <tr><td>3.110</td><td>17.200</td></tr> <tr><td>3.830</td><td>18.300</td></tr> <tr><td>4.222</td><td>19.500</td></tr> <tr><td>5.333</td><td>20.600</td></tr> <tr><td>6.444</td><td>21.888</td></tr> <tr><td>7.555</td><td>22.000</td></tr> <tr><td>8.666</td><td>23.000</td></tr> <tr><td>9.000</td><td>24.900</td></tr> <tr><td>10.777</td><td>25.000</td></tr> <tr><td>11.400</td><td>26.000</td></tr> <tr><td>12.700</td><td>27.000</td></tr> <tr><td>13.100</td><td>28.009</td></tr> <tr><td>14.800</td><td>29.990</td></tr> </table>				2.000 MHz	15.000 MHz	2.830	16.000	3.110	17.200	3.830	18.300	4.222	19.500	5.333	20.600	6.444	21.888	7.555	22.000	8.666	23.000	9.000	24.900	10.777	25.000	11.400	26.000	12.700	27.000	13.100	28.009	14.800	29.990
2.000 MHz	15.000 MHz																																
2.830	16.000																																
3.110	17.200																																
3.830	18.300																																
4.222	19.500																																
5.333	20.600																																
6.444	21.888																																
7.555	22.000																																
8.666	23.000																																
9.000	24.900																																
10.777	25.000																																
11.400	26.000																																
12.700	27.000																																
13.100	28.009																																
14.800	29.990																																
51	Connect the equipment as shown in figure 4-25. Connect the AN/URM-145 to the IF output. Set the receiver to 2.000 MHz, set the attenuator to 80 db, and set the AN/GRM-50 output to 5.0 mv rms as indicated on the ME-30(*)/U at 2.001 MHz \pm 100 Hz. Measure the signal plus noise to noise ratio (S + N) by noting the reading in db without a signal applied, and subtracting it from the reading in db with a signal applied.	----- 10 db minimum.																															
52		<p>a. Set SERVICE SELECTOR switch to CW.</p> <p>b. Read and record CW power output.</p> <p>c. Switch the remote keying switch from the ground position to the 500 ohm position.</p> <p>d. Return Remote Key switch to the ground position.</p>	c. The power output measured shall not vary from that recorded in b above.																														
53	Disconnect all cables.																																

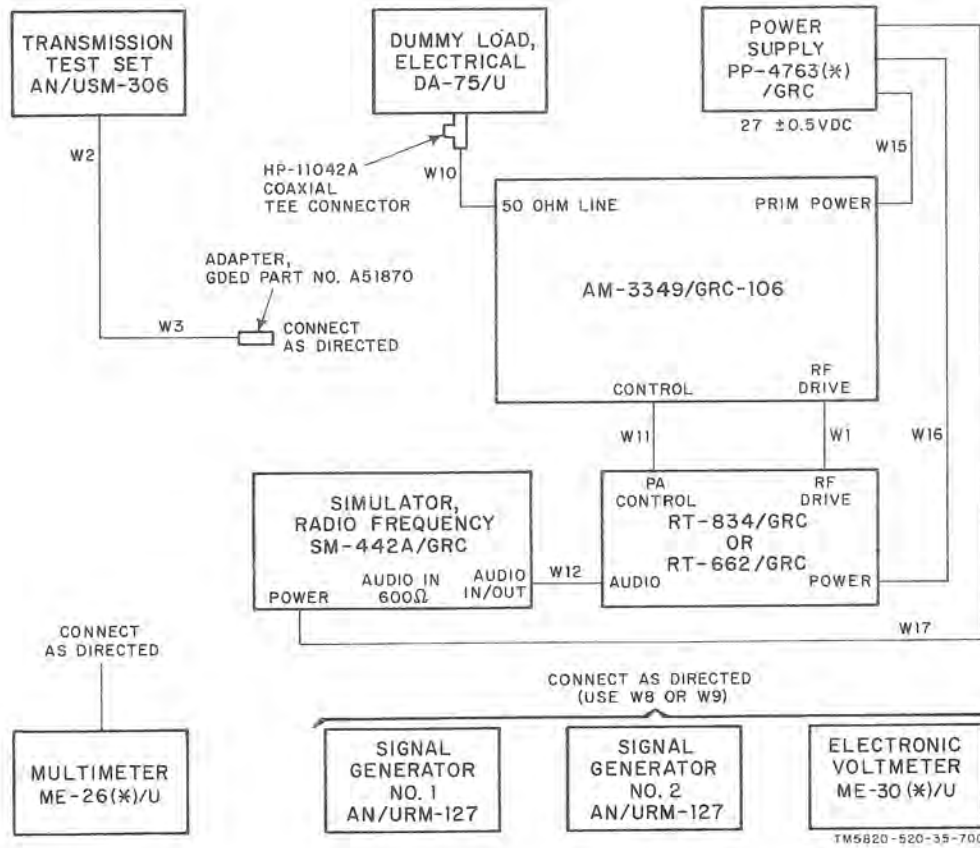

Figure 3-69. Radio Set AN/GRC-106(*) system tests.

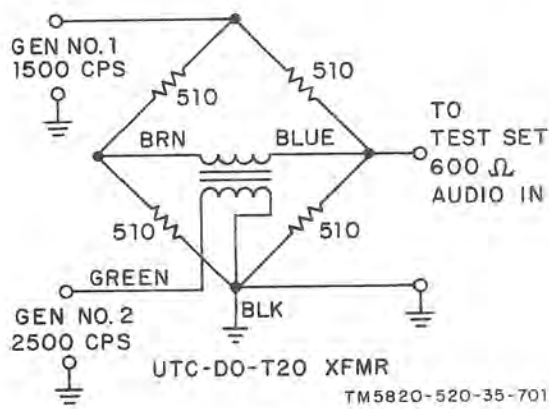

Figure 3-70. Intermodulation bridge, schematic diagram.

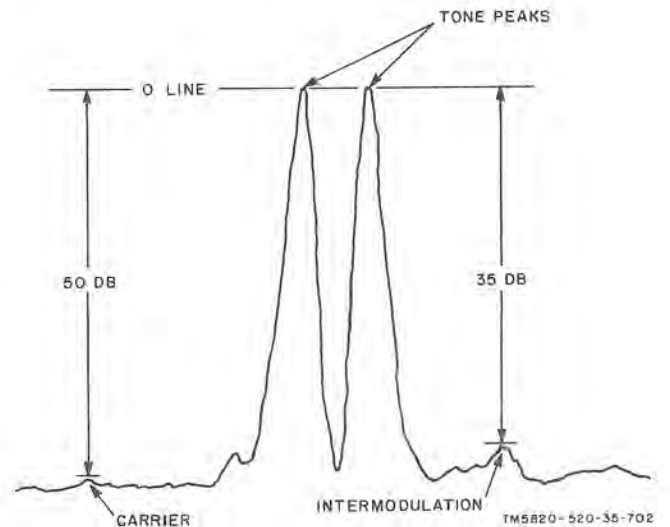

Figure 3-71. Oscilloscope presentation, AN/GRC-106(*) radio set system tests.

CHAPTER 4

GENERAL SUPPORT MODULE TESTING

Section I. MODULE TEST PROCEDURES

4-1. General

WARNING

When servicing Radio Set AN/GRC-106(*), be extremely careful when working on or around the circuits of dc-to-dc converter and regulator module 1A11, dc-to-dc inverter (part of case assembly 2A6), antenna coupler 2A3, and front panel assembly 2A5, voltages as high as 3,000 volts dc and 10,000 volts RF exist in these assemblies.

CAUTION

The equipment is transistorized. When measuring voltages, use tape of sleeving (spaghetti) to insulate the entire test prod, except the extreme tip. A momentary short circuit can ruin a transistor.

The following test procedures are for use by general support maintenance personnel to determine the acceptability of repaired modules. The procedures set forth specific requirements that repaired modules must meet before being returned to the using organization. Module and assembly tests are covered in tables 4-1 through 4-18. Test equipment requirements and test setups are shown in figures 4-1 through 4-17.

4-2. Test Equipment Required for General Support Module Tests

Table 3-1 includes the test equipment required for general support module testing and the associated technical manuals. Cables, load adapters, and tee connector adapters are shown in figures 4-1 through 17 and are supplied with Simulator, Radio Frequency SM-442A/GRC.

4-3. Preliminary Test Procedures

To conduct one of the tests listed in tables 4-1 through 4-18 proceed as follows:

- a. Set up the test equipment according to the appropriate illustration specified by the performance test tables.
- b. From the test setup illustration, determine the proper tray to be used (if any), and plug the tray into the RF Simulator SM-442A/GRC.
- c. Remove the dust cover from the module to be tested, and plug it into the tray. When tray A3 is used it is used with the five modules supplied with SM-442A/GRC.
- d. Make the preliminary settings for the test set according to TM 11-6625-847-12.
- e. Proceed to the individual performance test table for the module to be tested.

Section II. RT-662/GRC AND RT-834/GRC MODULE TESTS, AND AM-3349/GRC-106 ASSEMBLY TESTS

4-4. RT-662/GRC and RT-834/GRC Module Performance Tests

The tests contained in tables 4-1 through 4-9 apply to RT-662/GRC and RT-834/GRC

except where otherwise noted. Additional procedures which apply only to RT-834/GRC modules 1A4 and 1A1A2A8 are found in tables 4-10 and 4-11.

Table 4-1. 100 kHz Synthesizer Module 1A2, Proof of Performance Tests

Step	Operation of test equipment	Performance standard
1	<p>Voltage checks:</p> <p>a. Refer to TM 11-6625-847-12 for preliminary control settings on the test set and tray A3.</p> <p>b. On the test set, set the PA-RT switch to RT and the SERV SEL switch to STBY.</p> <p>c. On tray A3 end panel, set MODULE SELECT switch to 100 kHz and set tray A3, 100 kHz control SELECT FREQ section to 0.</p> <p>d. Turn on all equipment.</p>	
	NOTE	
	<p>1. For test points and test equipment connections, refer to figure 4-1.</p> <p>2. All tray A3 control panel designations used throughout these module tests refer to 100 kHz SYNTH section unless otherwise specified.</p>	
	<p>e. Connect TS-352B/U to tray A3 POWER section INPUTS FIXED test points. Observe multimeter indication. Adjust test set DC VOLTAGE 20 control if necessary.</p>	20 \pm 0.5 vdc
	<p>f. Set tray A3 POWER section VAR/FIXED switch to VAR.</p>	
	<p>g. Connect TS-352B/U to tray A3 POWER section INPUTS VAR test point. Observe TS-352B/U indication. Adjust tray A3 POWER ADJ. control if necessary.</p>	19 \pm 0.5 vdc
	<p>h. Disconnect TS-352B/U.</p>	
	NOTE	
	<p>To insure accuracy of frequency standard, allow 1 hour warmup time for frequency standard module and frequency measurement equipment.</p>	
	<p>i. Connect AN/URM-145 to tray A3 FREQ STANDARD section 10 MHz connector.</p>	
	<p>j. Set tray A3 FREQ STANDARD section 10 MHz OUTPUT AMPL ON-OFF switch to ON and adjust 10 MHz amplifier VOLT ADJ control for 30 mv rms indication on AN/URM-145.</p>	
	<p>k. Disconnect AN/URM-145 and connect it to tray A3, 10 and 1 kHz SYNTH section 7.1 MHz connector.</p>	
	<p>l. Set tray A3, 10 and 1 kHz SYNTH section 7.1 MHz AMPL ON-OFF switch to ON and adjust 7.1 MHz amplifier VOLT ADJ control for 25 mv rms indication on AN/URM-145.</p>	
	<p>m. Disconnect AN/URM-145.</p>	
	<p>n. Connect AN/USM-306 (terminated in 50 ohms) to tray A3 FREQ DIVIDER section 100 kHz SPECTRUM connector. Adjust AN/USM-306 tuning through range of 15.3 MHz to 16.2 MHz; observe indication at each 100 kHz interval.</p>	20 \pm 10 mv rms at each point observed; -27 to -17.5 dbm
	<p>o. Disconnect AN/USM-306.</p>	
2	<p>100 kHz synthesizer output test:</p>	
	<p>a. Set test set 1 MHz frequency control to 6 and observe tray A3 1 MHz SYNTH section HI lamp.</p>	HI lamp lights
	<p>b. Connect AN/URM-145 to 100 kHz synthesizer tray A3 100 kHz SYNTH OUPT test point.</p>	
	<p>c. Observe AN/URM-145 while setting tray A3 FREQ SELECT section 100 kHz control to each of its positions (0-9). Note that MHz SYNTH section HI lamp remains lighted.</p>	140 \pm 10 mv rms at each position
	<p>d. Set test set 1 MHz frequency control to 5 and observe tray A3 1 MHz SYNTH section HI and LO lamps.</p>	LO lamp lights and HI lamp goes out
	<p>e. Observe AN/URM-145 while setting tray A3 FREQ SELECT section 100 kHz control to each of its positions (0-9). Note that MHz SYNTH section LO lamp remains lighted.</p>	110 \pm 10 mv rms
	<p>f. Set tray A3 FREQ SELECT section 100 kHz control to 0.</p>	
	<p>g. Disconnect AN/URM-145.</p>	

Table 4-1. 100 kHz Synthesizer Module 1A2, Proof of Performance Tests—Continued

Step	Operation of test equipment	Performance standard
3	100 kHz synthesizer output frequency test:	
	a. Connect AN/USM-207 to tray A3 FREQ STANDARD section 10 MHz connector. Observe AN/USM-207 indication.	10 MHz ± 1 Hz
	b. Disconnect AN/USM-207 and connect it to tray A3, 10 and 1 kHz SYNTH section 7.1 MHz connector.	
	c. Observe the AN/USM-207 indication and record the error factor within the specified limits of ±400 Hz.	7.1 MHz ± 400 Hz
	d. Disconnect AN/USM-207 and connect it to tray A3, 100 kHz SYNTH OUTPUT connector.	
	e. Set test set MHz FREQ and tray A3 FREQ SELECT section 100 kHz controls as listed below and observe AN/USM-207 indication for each frequency setting.	

MHz FREQ		FREQ SELECT		
10 MHz	1 MHz	1 MHz	100 kHz	
0	5	0	0	22.4 MHz ± 400 Hz
0	5	0	1	22.5 MHz ± 400 Hz
0	5	0	2	22.6 MHz ± 400 Hz
0	5	0	3	22.7 MHz ± 400 Hz
0	5	0	4	22.8 MHz ± 400 Hz
0	5	0	5	22.9 MHz ± 400 Hz
0	5	0	6	23.0 MHz ± 400 Hz
0	5	0	7	23.1 MHz ± 400 Hz
0	5	0	8	23.2 MHz ± 400 Hz
0	5	0	9	23.3 MHz ± 400 Hz
0	6	0	0	32.4 MHz ± 400 Hz
0	6	0	1	32.5 MHz ± 400 Hz
0	6	0	2	32.6 MHz ± 400 Hz
0	6	0	3	32.7 MHz ± 400 Hz
0	6	0	4	32.8 MHz ± 400 Hz
0	6	0	5	32.9 MHz ± 400 Hz
0	6	0	6	33.0 MHz ± 400 Hz
0	6	0	7	33.1 MHz ± 400 Hz
0	6	0	8	33.2 MHz ± 400 Hz
0	6	0	9	33.3 MHz ± 400 Hz

NOTE

The error factor observed for each of the listed frequencies should be the same as recorded in step 3c above. (Output frequency error is a direct function of the 7.1 MHz injection frequency.)

	f. Disconnect AN/USM-207.	
4	100 kHz synthesizer output spurious test:	
	a. Set test set 1 MHz frequency control to 5.	
	b. Set tray A3 FREQ SELECT section 100 kHz control to 0.	
	c. Connect AN/URM-145 to tray A3 FREQ STANDARD section 10 MHz connector.	
	d. Adjust tray A3 FREQ STANDARD section 10 MHz OUTPUT amplifier VOLT ADJ control for 70 mv rms indication on AN/URM-145.	
	e. Disconnect AN/URM-145 and connect it to tray A3, 10 and 1 kHz SYNTH section 7.1 MHz connector.	
	f. Adjust tray A3, 10 and 1 kHz SYNTH section 7.1 MHz OUTPUT amplifier VOLT ADJ control for 45 mv rms indication on AN/URM-145.	
	g. Disconnect AN/URM-145.	
	h. Attach AN/USM-306 to tray A3, 100 kHz SYNTH OUTPUT connector.	
	i. Set test set MHz FREQ and tray A3 FREQ SELECT section 100 kHz controls to each of the 20 frequencies listed in step 3e, and check each signal (up to 1 MHz on each side of center frequency) for spurious signal content.	All spurious signals 50 db down except 100 kHz points, which are 40 db down.
	j. Disconnect all test equipment.	

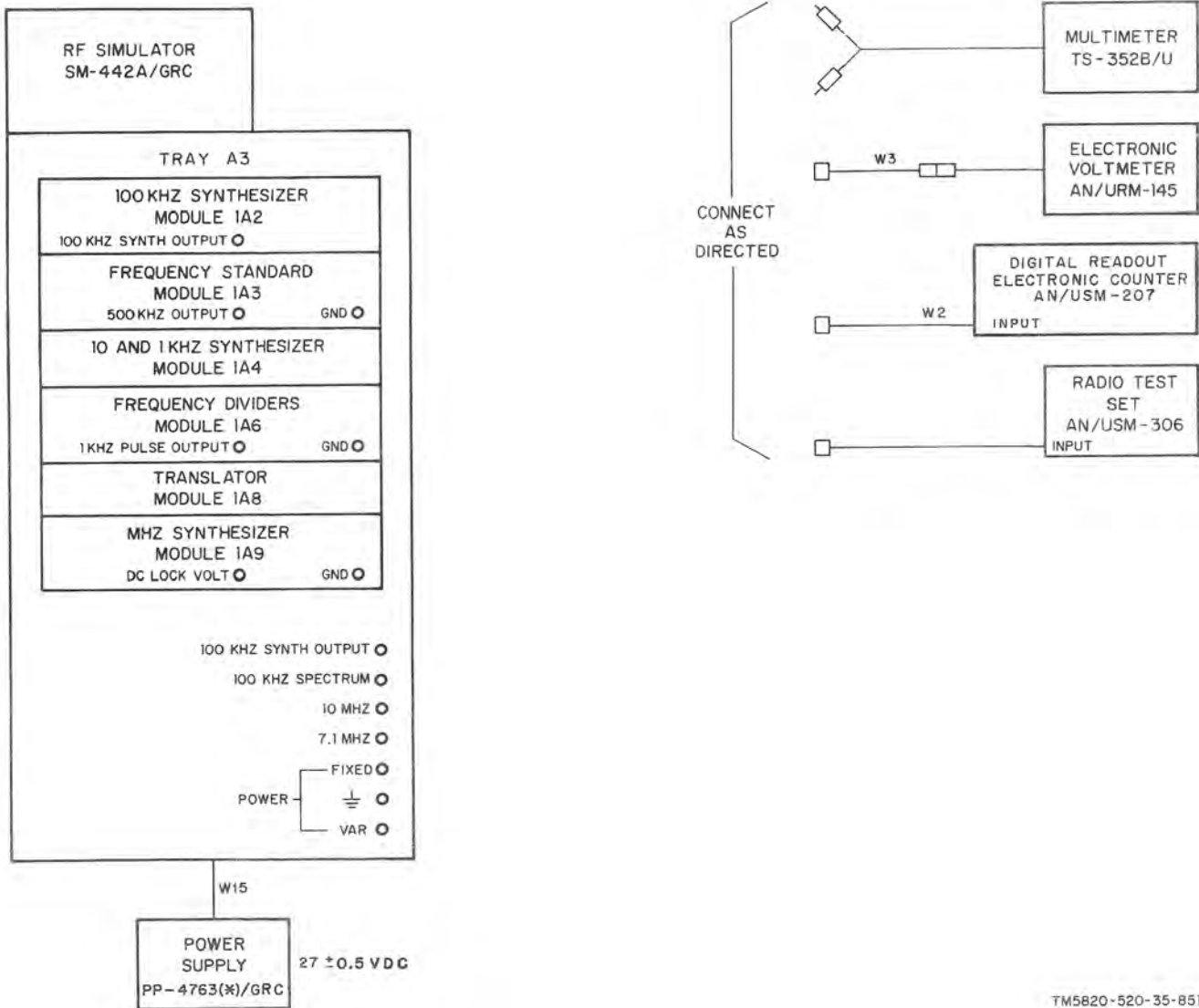

TM5820-520-35-851

Figure 4-1. 100 kHz synthesizer module 1A2, performance test setup.

Table 4-2. Frequency Standard Module 1A3, Proof of Performance Tests
(Refer to figure 4-2, 4-3(1), or 4-3(2).)

<i>Step</i>	<i>Operation of test equipment</i>	<i>Performance standard</i>
-------------	------------------------------------	-----------------------------

- 1 Voltage checks:
 - a. Refer to TM 11-6625-847-12 for preliminary control settings on test set and tray A3.
 - b. Set test set PA-RT switch to RT and the SERV SEL switch to STBY.
 - c. Set tray A3 end and panel MODULE SELECT switch to FREQ STD.
 - d. Turn on all equipment.

NOTE

1. For test points and test equipment connections, refer to figure 4-2.
 2. All tray A3 control panel designations used throughout these module tests, refer to FREQ STANDARD section unless otherwise specified.
- e. Set tray A3 POWER VAR-FIXED switch to FIXED. Connect TS-352B/U to tray A3 POWER section INPUTS-FIXED OFF test point. Observe TS-352B/U indication. Adjust test set DC VOLTAGE 20 control if necessary.

+20 ±0.5 vdc

Table 4-2. Frequency Standard Module 1A3, Proof of Performance Tests—Continued

Step	Operation of test equipment	Performance standard
	f. Disconnect TS-352B/U.	
	g. Set tray A3 POWER section VAR-FIXED switch to VAR.	
	h. Connect TS-352B/U to tray A3 POWER section INPUTS-VAR test points; observe TS-352B/U indication. Adjust tray A3 POWER ADJ control if necessary.	+19.5 ± 0.5 vdc
	i. Disconnect TS-352B/U.	
NOTE		
To insure accuracy of frequency standards, allow 1 hour warm-up time for frequency standard module and frequency measurement.		
	j. Check to see that 5 MHz INT-EXT switch on frequency standard module is set to INT.	
	k. Connect AN/URM-145 to 5 MHz INT-EXT test point on frequency standard module, and observe indication.	125 ± 25 mv rms
	l. Connect AN/URM-145 with 50 ohm dummy load to tray A3, 5 MHz EXT-INT tee adaptor. Observe AN/URM-145 indication.	250 ± 50 mv rms
	m. Disconnect AN/URM-145 and 50 ohm dummy load.	
	n. Connect AN/USM-207 to tray A3, 5 MHz EXT-INT tee adaptor and observe indication.	5 MHz Hz +0.0 -0.6
NOTE		
If frequency standard frequency is above 5.0 MHz, adjust its frequency to the low end of the tolerance (-0.6 Hz). This will allow for normal aging of the crystal.		
	o. Disconnect AN/USM-207.	
2	10 MHz Output Test (Internal Standard):	
	a. Connect AN/URM-145 with 50 ohm dummy load to frequency standard module 10 MHz OUPPT test point and observe indication.	50 ± 15 mv rms
	b. Disconnect AN/URM-145 and 50 ohm load.	
	c. Connect AN/USM-207 to tray A3, 10 MHz connector. Set AN/USM-207 for counting interval of 10 seconds and observe indication.	10 MHz Hz +0.0 -1.1
	d. Disconnect AN/USM-207.	
3	1 MHz Output Test (Internal Standard):	
	a. Connect AN/URM-145 (terminated in 50 ohms) to tray A3, 1 MHz connector and observe indication.	500 ± 100 mv rms
	b. Disconnect AN/URM-145 and 50 ohm termination.	
	c. Connect AN/USM-207 to tray A3, 1 MHz connector and observe indication.	1 MHz Hz +0.0 -0.2
	d. Disconnect AN/USM-207.	
4	500 kHz Output Test (Internal Standard):	
	a. Connect AN/URM-145 (terminated with 50 ohms adaptor) to 500 kHz OUT test point on frequency standard module and observe indication.	220 ± 30 mv rms
NOTE		
Verify that frequency divider module 1A6 is not installed on tray A3 as it would affect the loading of the 1A3 module output.		
	b. Disconnect AN/URM-145 and 50 ohm adaptor.	
	c. Connect AN/USM-207 to 500 kHz OUT test point on frequency standard module and observe indication.	500 kHz Hz +0.0 -0.1
	d. Disconnect AN/USM-207.	
5	External Standard Operation Test:	
	a. Set INT-EXT switch on frequency standard module to EXT.	
	b. Connect AN/USM-207 to tray A3, 5 MHz EXT-INT tee adapter.	
	c. Connect AN/GRM-50 to tray A3, 5 MHz EXT-INT tee adapter.	
	d. Adjust AN/GRM-50 for 5 MHz output frequency as indicated by AN/USM-207 and 75 mv rms output level as indicated by panel meter.	

Table 4-2. Frequency Standard Module 1A3, Proof of Performance Tests—Continued

Step	Operation of test equipment	Performance standard
	e. Connect AN/URM-145 with 50 ohm dummy load to 500 kHz OUT test point on frequency standard module.	
	f. After checking AN/USM-207 indication to confirm accuracy of AN/GRM-50, observe AN/URM-145 indication.	220 ± 30 mv rms
	g. Disconnect AN/URM-145 and load and connect it with 50 ohm load to tray A3, 1 MHz connector.	
	h. After checking AN/USM-207 indication to confirm accuracy of AN/GRM-50, observe AN/URM-145 indication.	500 ± 100 mv rms
	i. Disconnect AN/URM-145 and load and connect it with 50 ohm load to frequency standard module 10 MHz OUPT test point.	
	j. After checking AN/USM-207 indication to confirm accuracy of AN/GRM-50, observe AN/URM-145 indication.	+110 50 mv rms - 25
	k. Disconnect AN/URM-145 and load.	
	l. Increase AN/GRM-50 output level to 3.0 v rms as indicated by panel meter.	
	m. Repeat steps 5e through j above.	
	n. Disconnect AN/URM-145 and 50 ohm load.	
6	Frequency Locking Test:	
	a. Decrease AN/GRM-50 output level to 75 mv rms as indicated by panel meter.	
	b. Disconnect AN/USM-207 and connect AN/USM-281A vertical input to tray A3, 5 MHz EXT-INT tee adapter.	
	c. Connect horizontal input of AN/USM-281A to tray A3, 1 MHz connector and observe lissajous waveform.	5:1 locked lissajous waveform, Lissajous waveform peaks may be superimposed due to phase relationship of locked frequencies, as shown below (A, fig. 4-3).
	d. Increase AN/GRM-50 output level to 3.0 v rms as indicated by panel meter and observe lissajous waveform.	5:1 locked lissajous waveform remains.
	e. Decrease AN/GRM-50 output level to 75 mv rms as indicated by panel meter and disconnect HORIZ. INPUT.	
	f. Connect horizontal input of AN/USM-281A to 500 kHz OUT test point on frequency standard module and observe lissajous waveform.	10:1 locked lissajous waveform. Lissajous waveform peaks may be superimposed due to phase relationship of locked frequencies, as shown in B, figure 4-3.
	NOTE	
	It may be possible to obtain a better display by interchanging AN/USM-281A horizontal and vertical inputs, and/or utilizing 5 X magnifier on the AN/USM-281A.	
	g. Increase AN/GRM-50 output level to 3.0 v rms as indicated by panel meter and observe lissajous waveform.	10:1 locked lissajous waveform,
	h. Disconnect AN/GRM-50.	
	i. Connect TS-352B/U to tray A3 POWER section INPUTS-VAR test point and observe indication.	+19.5 ±0.5 vdc
	j. Set INT-EXT switch on frequency standard module to INT and observe lissajous waveform.	10:1 locked lissajous waveform
	k. Connect horizontal input of AN/USM-281A to tray A3, 1 MHz connector and observe lissajous waveform.	5:1 locked lissajous waveform
	l. Adjust tray A3 POWER section ADJ control for +15 volt dc indication on TS-352B/U and observe lissajous waveform.	5:1 locked lissajous waveform
	m. Adjust tray A3 POWER section ADJ control for +19.5 volt dc indication on TS-352B/U.	
	n. Disconnect all test equipment.	

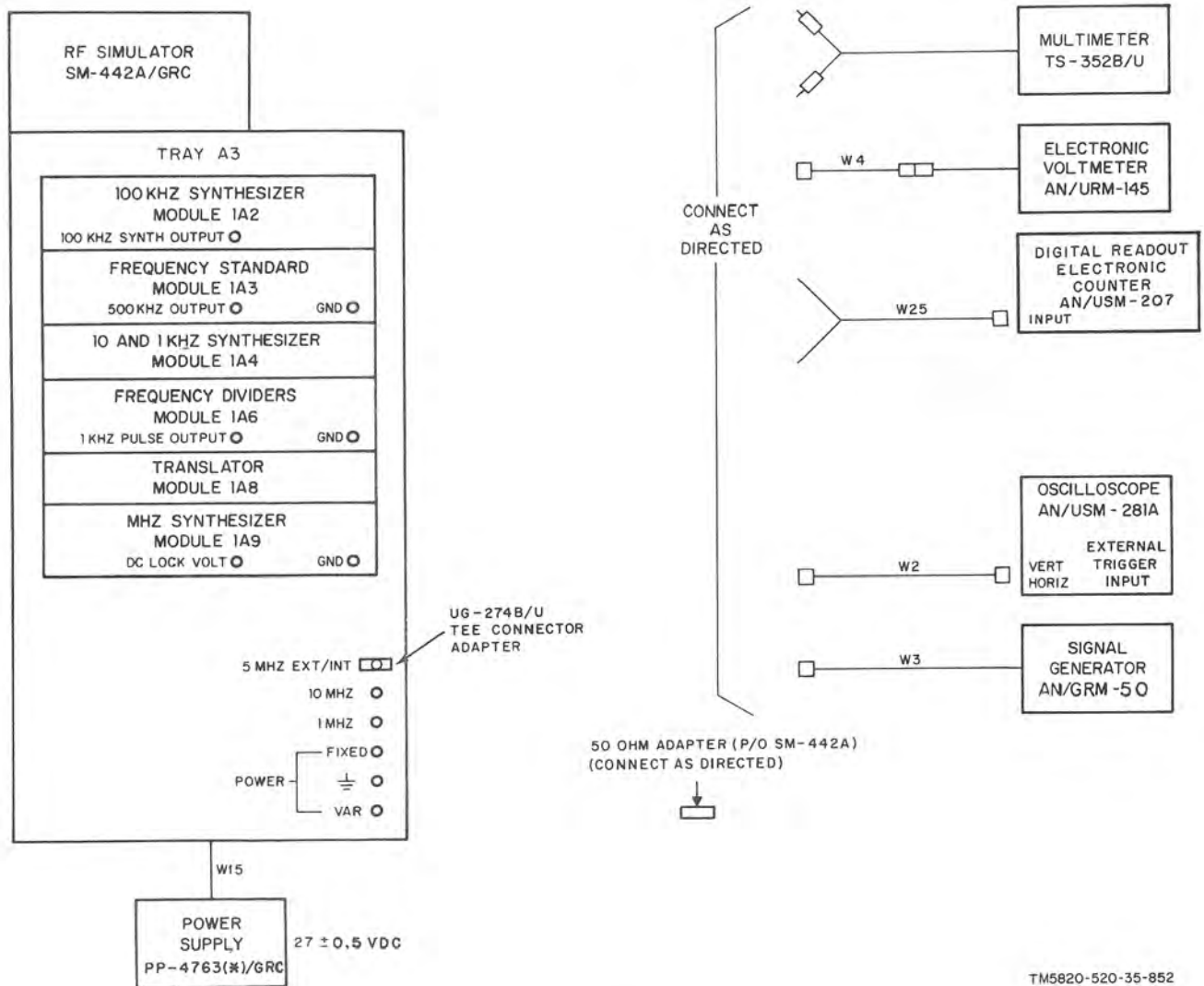

TM5820-520-35-852

Figure 4-2. Frequency standard module 1A3, performance test setup.



A



B



C



D



E

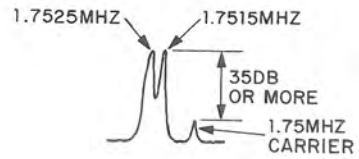

F

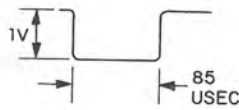

G

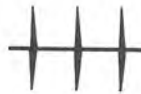

H

APPROX. 2 v p-p



I

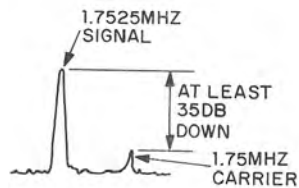

J

TM5820-520-35-853 ①

Figure 4-3(1). Module testing waveform diagrams (sheet 1 of 2).

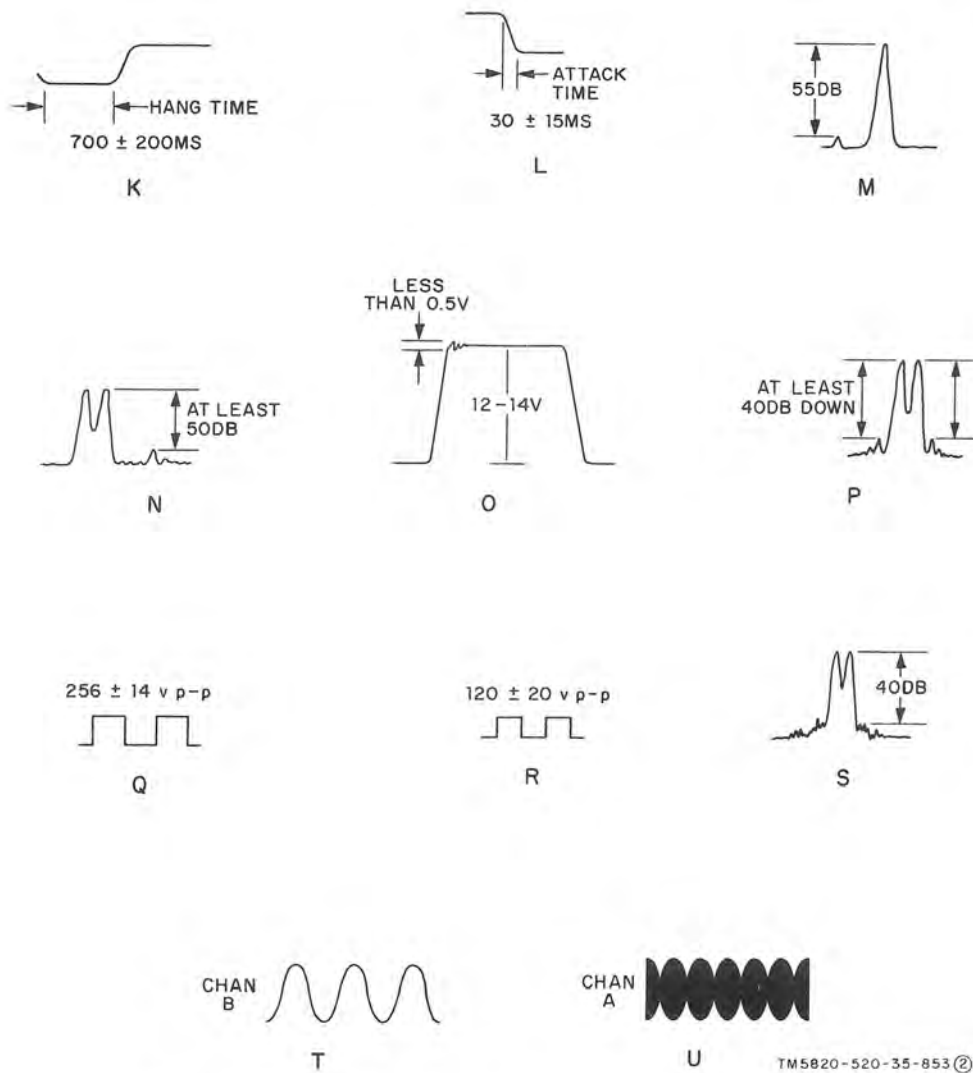

TM5820-520-35-853 ©

Figure 4-3(2). Module testing waveform diagrams (sheet 2 of 2).

Table 4-3. 10 and 1 kHz Synthesizer Module 1A4 (RT-662/GRC), Proof of Performance Tests
(Refer to figure 4-4.)

<i>Step</i>	<i>Operation of test equipment</i>	<i>Performance standard</i>
-------------	------------------------------------	-----------------------------

1

NOTE

The test procedures contained in this table with exception of step 1, are applicable for RT-662/GRC only. Refer to table 4-10 for tests applicable to RT-834/GRC.

Voltage Checks:

- a. Refer to TM 11-6625-847-12 for preliminary control of test and tray A3.
- b. Set test set PA-RT switch to RF and SERV SEL switch to STBY.
- c. Set tray A3 end panel MODULE SELECT switch to 10 and 1 kHz.
- d. Turn on all equipment.

NOTE

1. For test points and test equipment, connections, refer to figure 4-4.
2. All tray A3 control panel designations used throughout these module tests, refer to 10 and 1 kHz SYNTH section unless otherwise specified.

Table 4-3. 10 and 1 kHz Synthesizer Module 1A4 (RT-662/GRC),
Proof of Performance Tests—Continued

Step	Operation of test equipment	Performance standard
e.	Connect TS-352B/U to tray A3 POWER section FIXED test point and observe TS-352B/U indication. Adjust test set DC VOLTAGE 20 control, if necessary.	+20 ±0.5 vdc
f.	Disconnect TS-352B/U.	
g.	Set tray A3 POWER section POWER VAR-FIXED switch to VAR.	
h.	Connect TS-352B/U to tray A3 POWER section VAR test point and observe TS-352B/U indication. Adjust tray A3 POWER section ADJ control if necessary.	+19.5 ±0.5 vdc
i.	Disconnect TS-352B/U.	
NOTE		
To insure accuracy of frequency standards allow 1 hour warmup for frequency standard module and frequency measurement equipment.		
2	7.1 Output Test:	
CAUTION		
If 1A4 module is from an RT-834/GRC chassis (indicated by 7.089 MHz stamped on top of module), proceed to table 4-10.		
a.	Set test set POWER switch to OFF. Remove 10 and 1 kHz synthesizer module from tray A3.	
b.	Set test set POWER switch to ON. Connect AN/USM-281A to 1A6 frequency dividers module 1 kHz PULSE OUP T test point and observe pulse on AN/USM-281A.	Amplitude (p-p): 1.3 ±0.3 volts. Width: 100 ±20 μsec. PRF: 1 kHz (locked to 500 kHz freq std) (C, fig. 4-3).
c.	Set test set POWER switch to OFF, reinstall 10 and 1 kHz synthesizer module on tray A3; then set test POWER switch to ON.	
d.	Disconnect AN/USM-281A and connect it to tray A3 FREQ DIVIDER section, 10 kHz SPECTRUM connector. On AN/USM-281A connect vertical signal output to delayed trigger connector and adjust horizontal delay sweep and main sweep control to produce 10 kHz spectrum pulse display. Observe pulse on AN/USM-281A.	Amplitude (p-p): 110 ±30 mv. Width: 7.5 ±5 μsec PRF: 10 kHz (D, fig. 4-3).
e.	Disconnect AN/USM-281A.	
f.	Connect AN/USM-306 (terminated in 50 ohms) to tray A3, FREQ. DIVIDER section, 10 kHz SPECTRUM connector.	
g.	Adjust AN/USM-306 to 2.48 MHz and then to 2.57 MHz; observe indication for each frequency.	2.48 MHz: 2.6 ±1.2 mv rms. 2.57 MHz: 2.6 ±1.2 mv rms.
h.	Turn test set 10 and 1 kHz OUTPUT AMPL switch OFF. Disconnect AN/USM-306 (terminated in 50 ohms) and connect it to tray A3, 7.1 MHz connector.	
i.	Adjust AN/USM-306 to 7.1 MHz and observe indication. Adjust 7.1 MHz level control as necessary.	35 ±5 mv rms.
j.	Set tray A3 FREQ SELECT SECTION 10 kHz control to each of its positions; observe AN/USM-306 indication at each position (0-9). Use wide band on AN/USM-306.	All positions: 35 ±5 mv rms.
k.	Set tray A3 FREQ SELECT section 1 kHz control to each position and observe AN/USM-306 indication at each position (0-9).	All positions: 35 ±5 mv rms.
l.	Adjust AN/USM-306 to 9.07 MHz and observe indication.	1 mv rms maximum.
m.	Repeat steps j and k above.	All positions 10 kHz and 1 kHz FREQ SELECT controls: 1 mv rms maximum.
n.	Adjust AN/USM-306 to 7.1 MHz and observe any spurious responses within ±100 kHz of 7.1 MHz.	Spurious responses to be minimum of 05 db down from level of 7.1 MHz signal measured in i above.
o.	Disconnect AN/USM-306.	
p.	Connect AN/USM-207 to tray A3, 7.1 MHz connector and observe AN/USM-207 indication.	7.1 MHz ±400 Hz.
q.	Disconnect AN/USM-207.	

Table 4-3. 10 and 1 kHz Synthesizer Module 1A4 (RT-662/GRC),
Proof of Performance Tests—Continued

Step	Operation of test equipment	Performance standard
3	10 and 1 kHz Output Test:	
	a. Connect AN/URM-145 to tray A3 SYNTH OUTPUTS 10 and 1 kHz connector. Turn tray A3, 10 and 1 kHz SYNTH OUP-AMPL to OFF.	
	b. Set tray A3 FREQ SELECT section 10 kHz control to each position and observe AN/URM-145 indication at each position (0-9).	All positions: 120 ±30 mv rms.
	c. Set tray A3 FREQ SELECT section 1 kHz control to each position and observe AN/URM-145 indication at each position (0-9).	All positions: 120 ±30 mv rms.
	d. Disconnect AN/URM-145.	
	e. Connect AN/USM-207 to tray A3, 10 and 1 kHz connector.	
	f. Set tray A3 FREQ SELECT section 10 kHz and 1 kHz controls as listed below and observe AN/USM-207 indication:	
	<i>FREQ SELECT</i>	
	10 kHz	1 kHz
	0-----0-----	4.650 MHz ±400 Hz
	1-----0-----	4.640 MHz ±400 Hz
	2-----0-----	4.630 MHz ±400 Hz
	3-----0-----	4.620 MHz ±400 Hz
	4-----0-----	4.610 MHz ±400 Hz
	5-----0-----	4.600 MHz ±400 Hz
	6-----0-----	4.590 MHz ±400 Hz
	7-----0-----	4.580 MHz ±400 Hz
	8-----0-----	4.570 MHz ±400 Hz
	9-----0-----	4.560 MHz ±400 Hz
	9-----1-----	4.559 MHz ±400 Hz
	9-----2-----	4.558 MHz ±400 Hz
	9-----3-----	4.557 MHz ±400 Hz
	9-----4-----	4.556 MHz ±400 Hz
	9-----5-----	4.555 MHz ±400 Hz
	9-----6-----	4.554 MHz ±400 Hz
	9-----7-----	4.553 MHz ±400 Hz
	9-----8-----	4.552 MHz ±400 Hz
	9-----9-----	4.551 MHz ±400 Hz
	g. Disconnect AN/USM-207.	
	h. Attach AN/USM-306 to tray A3, 10 and 1 kHz connector.	
	i. Set tray A3 FREQ SELECT 10 kHz and 1 kHz switch controls to each of the 19 frequencies listed in step f above, and observe each signal (up to 100 kHz each side of center frequency) for spurious signal content.	All spurious signals more than 60 db down
	j. Set tray A3 FREQ SELECT section 10 kHz control to 9 and 1 kHz control to 9 to produce nominal 4.551 MHz signal (item 19 in step 3f above).	
	k. Adjust AN/USM-306 to 4.551 MHz signal and record indication.	
	l. Adjust AN/USM-306 to observe 6.5 MHz signal level.	Signal at 6.5 MHz is down more than 50 db from 4.551 MHz signal
	m. Disconnect AN/USM-306.	
4	Oscillator Starting Test:	
	a. Connect AN/USM-281A to tray A3, 10 and 1 kHz connector and note appearance of waveform present.	E, figure 4-3
	b. Connect TS-352B/U to tray A3 POWER section VAR test point. Observe TS-352B/U indication.	+19.5 ±0.5 vdc
	c. Adjust tray A3 POWER section ADJ control for 0 or minimum voltage, as indicated by TS-352B/U and observe AN/USM-281A.	No waveform present on AN/USM-281A.
	d. Adjust tray A3 POWER section ADJ control to increase voltage until waveform reappears on AN/USM-281A. Observe TS-352B/U indication at which waveform first reappears.	Voltage level of not more than +18 vdc causes waveform to reappear
	e. Readjust tray A3 POWER section ADJ control for +19.5 vdc as indicated by multimeter.	

Table 4-3. 10 and 1 kHz Synthesizer Module 1A4 (RT-662/GRC), Proof of Performance Tests—Continued

- | Step | Operation of test equipment | Performance standard |
|------|---|----------------------|
| f. | Repeat steps c through e above for each of the 19 frequency settings listed in step 3f. | |
| g. | Disconnect TS-352B/U. | |
| h. | Disconnect all test equipment. | |

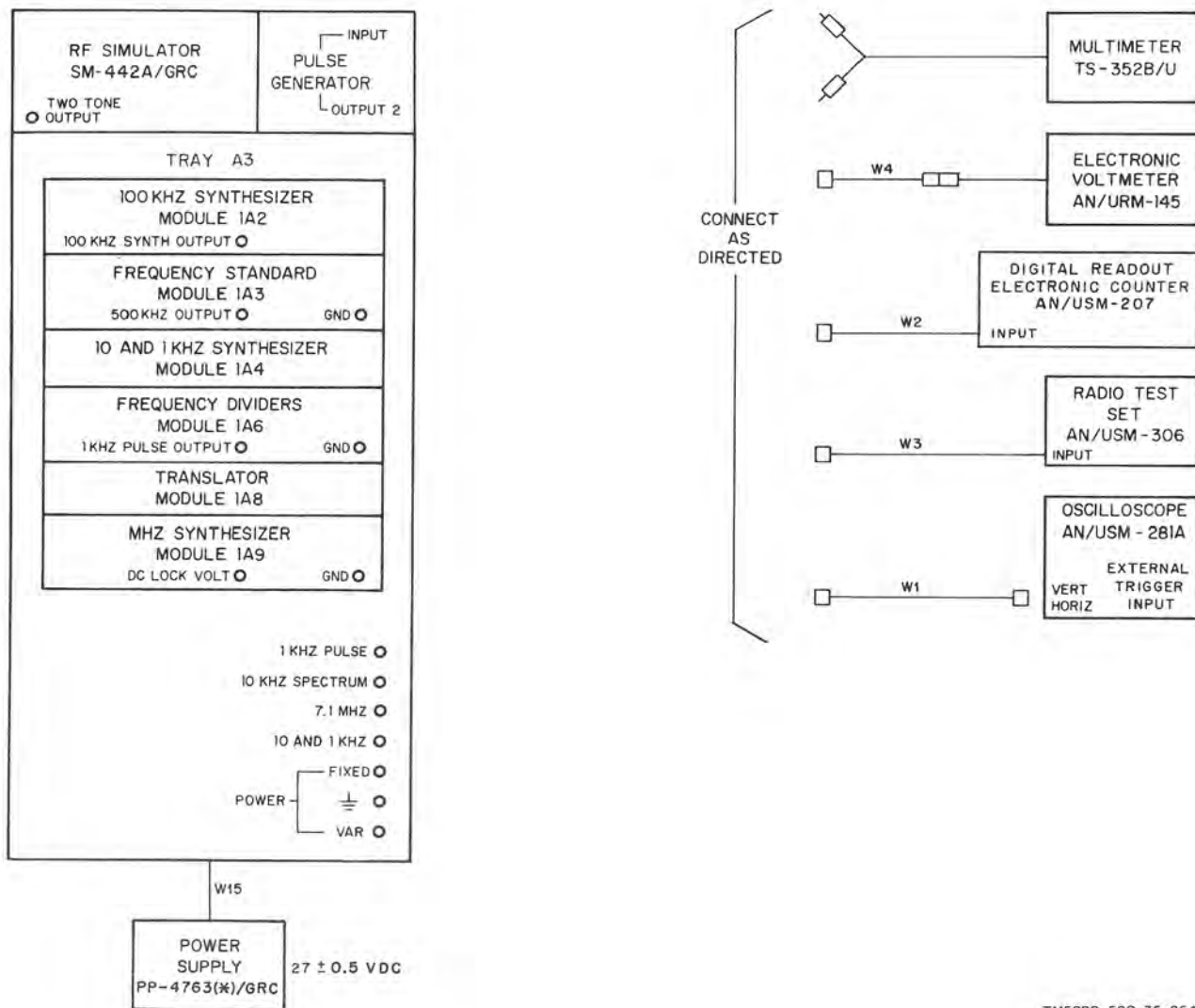

TM5820-520-35-854

Figure 4-4. 10 and 1 kHz synthesizer module 1A4, performance test setup.

Table 4-4. Transmitter IF and Audio Module 1A5, Proof of Performance Tests (Refer to figure 4-5).

- | Step | Operation of test equipment | Performance standard |
|------|--|----------------------|
| 1 | <p>Voltage Check:</p> <ol style="list-style-type: none"> On test set, set SERV SEL switch to SSB/NSK. PA-RT switch to RT, and TWO TONE SELECTOR switch to 1. Set tray A2, APC-PPC SEL switch to OFF, and VOICE MODES switch to PUSH TO TALK. Turn on all equipment. | |

Table 4-4. Transmitter IF and Audio Module 1A5, Proof of Performance Tests—Continued

Step	Operation of test equipment	Performance standard
NOTE		
	1. To insure accuracy of frequency standards, allow 1 hour warm-up time for the Spectrum Analyzer TS-723(*)/U and the two-tone setup. 2. For test points and test equipment connections, refer to figure 4-5. 3. All tray A2 control panel designations used throughout these module tests refer to XMTR IF AND AUDIO section unless otherwise specified.	
	d. Set tray A2, TEST SELECTOR switch to 1.	
	e. Connect TS-352B/U to tray A2, XMTR IF AND AUDIO HI and LO jacks and observe positive voltage. Adjust test set DC VOLTAGE 20 control if necessary.	+20 ±0.5 vdc
2	50 Ohm Bias Test:	
	a. Disconnect TS-352B/U and connect it for measuring current: positive lead to tray A2, INPUT 50 Ω AUDIO, and negative lead to ground. Observe TS-352B/U indication.	35 ±5 ma dc
	b. Disconnect TS-352B/U.	
3	Agc Test:	
	a. Set AN/URM-127 tone to frequency of 1 kHz at level of 0.02 v rms and connect output to tray A2 COMMON section AUDIO 600 Ω IN connector.	
	b. Connect ME-30(*)/U to tray A2 AUDIO OUT connector and observe absolute indication at 1 kHz.	7 ±2 mv rms
	c. Set AN/URM-127 tone 1 level to 0.2 v rms and observe ME-30(*)/U indication.	8 ±2 mv rms
4	Audio Attenuation, CW:	
	On test set, set KEY switch to ON, SERV SEL switch to CW, and observe ME-30(*)/U indication.	Less than 2 mv
5	50 Ohm Input Test:	
	a. Set test set KEY switch to OFF.	
	b. Disconnect AN/URM-127 and connect its tone output to tee adapter on tray A2 INPUT 50 Ω AUDIO connector. Adjust AN/URM-127 output for 0.2 v rms, and repeat step 3b.	
	c. Set test set SERV SEL switch to SSB/NSK and observe ME-30(*)/U indication.	7 ±2 mv rms
	d. Disconnect ME-30(*)/U and audio generator.	
6	Im Products Test:	
	a. Set two-tone setup tone 1 output to frequency of 1.5 kHz at level of 0.2 v rms, and tone 2 output to frequency of 2.5 kHz at level of 0.2 v rms. Output levels should be across 600 ohm load.	
	b. Connect two-tone setup tone 1 and 2 output to tray A2 COMMON section AUDIO 600 Ω IN connector.	
	c. Connect TS-723(*)/U to tray A2 AUDIO OUT connector and note level of Im products with respect to reference level of tones 1 and 2.	Im products level down from reference level at least 45 db.
	d. Disconnect TS-723(*)/U.	
7	Frequency Response:	
	a. Set AN/URM-127 tone to frequencies listed below at level of 0.2 v rms as measured with ME-30(*)/U across 600 ohm load:	
	0.3 kHz	
	0.5 kHz	
	1 kHz	
	3.5 kHz	
	b. Connect ME-30(*)/U to tray A2 AUDIO OUT connector and observe indication at each frequency setting given in step a above.	Audio outputs to be within 1 db of each other.
	c. Disconnect AN/URM-127 and ME-30(*)/U.	

Table 4-4. Transmitter IF and Audio Module 1A5, Proof of Performance Tests—Continued

Step	Operation of test equipment	Performance standard
8	Keyline Output Receive:	
	a. Set tray A2 TEST SELECTOR switch to 5. b. Connect TS-352B/U for measuring current: positive lead to HI jack, and negative lead to LO jack on tray A2.	Current to be 0 to 10 ma
9	Keyline Output Transmit:	
	a. Set test set REC-XMIT switch to XMIT, KEY switch to ON, and observe TS-352B/U indication.	+50 400 ma -40
	b. Set tray A2 TEST SELECTOR switch to 4 and observe TS-352B/U indication.	+50 400 ma -40
	c. Set test set KEY switch to OFF and observe TS-352B/U indication.	Current to be 0 to 10 ma
	d. Set tray A2 TEST SELECTOR switch to 5.	
	e. Disconnect TS-352B/U and connect it between tray A2, KEY-LINE PA test point and ground for measuring voltage.	
	f. Connect shorting bar between tray A2, HI and LO jacks and observe TS-352B/U indication.	+27 ±3 vdc
	g. Set test set KEY switch to ON and observe TS-352B/U indication.	Less than +2.5 vdc
	h. Set test set KEY switch to OFF.	
	i. Set tray A2 TEST SELECTOR switch to 4 and observe TS-352B/U indication.	+27 ±2 vdc
	j. Set test set KEY switch to ON and observe TS-352B/U indication.	Less than +2.5 vdc
	k. Set test set KEY switch to OFF.	
10	Keyline Ground Test:	
	a. Turn off power to test set and tray A2, and remove shorting bar connected between tray A2, HI and LO jacks.	
	b. Disconnect TS-352B/U and connect it for measuring resistance between A2, KEYLINE PA and RT test points. Connect lead having negative polarity to PA test point and leading having positive polarity to RT test point and observe resistance indication.	Low resistance (diode forward biased).
	c. Reverse TS-352B/U leads and observe resistance.	High resistance (diode back biased).
	d. Disconnect TS-352B/U.	
11	Vox Sensitivity:	
	a. Turn on all power and set tray A2, VOICE MODES switch to VOX.	
	b. Connect TS-352B/U for measuring current: positive lead to HI jack, and negative lead to LO jack on tray A2.	
	c. Set AN/URM-127 tone output to frequency of 0.5 kHz at level of 10 mv rms, and connect output to tray A2, COMMON section AUDIO 600 Ω IN connector. Observe TS-352B/U indication.	+50 400 ma -40
	d. Decrease AN/URM-127 tone output level to 5 mv rms and observe TS-352B/U indication.	Less than 10 ma
	e. Increase AN/URM-127 tone output to 10 mv rms.	
	f. Set test set SERV SEL switch to FSK and observe TS-352B/U indication.	Less than 10 ma
	g. Set test set SERV SEL switch to AM and observe TS-352B/U indication.	+50 400 ma -40
	h. Set test set SERV SEL switch to CW and observe TS-352B/U indication.	Less than 10 ma
	i. Disconnect TS-352B/U.	
12	Hang-time Test:	
	a. Set test set SERV SEL to SSB/NSK, REC-XMIT switch to REC, and KEY switch to ON.	
	b. Set tray A2, VOICE MODES switch to PUSH TO VOX. Set AGC SYNC ON-OFF switch to OFF.	
	c. Connect AN/USM-281A to tray A2, KEY-LINE RT test point.	
	d. Connect AN/URM-127 tone output to tray A2, RCVR AUDIO section test points AUDIO IN connector.	
	e. Set AN/URM-127 tone output to frequency of 0.5 kHz at level of 200 mv rms.	

Table 4-4. Transmitter IF and Audio Module 1A5, Proof of Performance Tests—Continued

Step	Operation of test equipment	Performance standard
	f. Connect AN/USM-281A external trigger input to tray A2 RCVR AUDIO section test points SQUELCH SYNC connector.	
	g. Set tray A2 RCVR AUDIO SQUELCH SYNC switch to ON.	+50 400 ma -40
	h. Connect TS-352B/U for measuring current: positive lead to HI jack, and negative lead to LO jack on tray A2. Observe indication.	800 ±300 ms
	i. While operating tray A2, RCVR AUDIO section SQUELCH SYNC switch from ON to OFF, observe AN/USM-281A and measure hang-time of crt trace.	
	j. Set tray A2 VOICE MODES switch to PUSH TO TALK.	
	k. While operating test set SERV SEL switch from STBY to SSB/NSK, observe AN/USM-281A and note there is no hang-time.	
	l. Disconnect AN/USM-281A, AN/URM-127, and TS-352B/U.	
13	IF Circuitry Tests:	
	a. On test set, set TWO TONE SELECTOR switch to 1+2, REC-XMIT switch to XMIT, KEY switch to ON, and TUNE-OPERATE switch OPERATE.	
	b. On tray A2, set APC-PPC SEL switch to PPC, TEST SELECTOR switch to 3, and RCVR IF section AGC SYNC switch to ON.	
	c. Connect AN/USM-306 to test set TWO TONE OUT connector, and adjust 1.7515 level for output of -47 dbm as indicated by AN/USM-306.	
	d. Disconnect AN/USM-306 and connect it to tray A2 COMMON section IF OUT connector.	
	e. Connect TS-352B/U to PPC test point on transmitter IF and audio module for measuring voltage.	
	f. Adjust tray A2, ALC APC PPC POWER CONTROL for +15 volt dc indication on TS-352B/U.	
	g. Set tray A2, APC-PPC SEL switch to OFF and record AN/USM-306 indication.	
	h. Set tray A2, APC-PPC SEL switch to PPC and note AN/USM-306 indication.	At least 40 db below indication noted in step g above.
	i. On tray A2, set APC-PPC SEL switch to OFF and TEST SELECTOR switch to 2.	
	j. Disconnect TS-352B/U and connect it to tray A2, HI and LO jacks for measuring dc voltage.	
	k. Set tray A2, ALC switch to ON and adjust ALC APC PPC POWER CONTROL for +4 volt dc indication on TS-352B/U.	
	l. Set tray A2, ALC switch to OFF and note AN/USM-306 indication.	
	m. Set tray A2, ALC switch to ON and note AN/USM-306 indication.	At least 40 db below indication noted in step l above.
	n. On tray A2, set APC-PPC SEL switch to APC, TEST SELECTOR switch to 3, and ALC switch to OFF.	
	o. Disconnect TS-352B/U and connect it to APC test point on transmitter IF and audio module for measuring voltage.	
	p. Adjust tray A2, ALC APC PPC POWER CONTROL for +4.5 volt dc indication on TS-352B/U.	
	q. Set tray A2, APC-PPC SEL switch to OFF and note AN/USM-306 indication.	
	r. Set tray A2, APC-PPC SEL switch to APC and note AN/USM-306 indication.	At least 40 db below indication noted in step q above.
	s. Disconnect AN/USM-306.	
14	Hang-Time and ALC Meter:	
	a. On tray A2, set APC-PPC SEL switch to OFF, TEST SELECTOR switch to 2, and ALC switch to ON.	
	b. Adjust tray A2, ALC APC PPC POWER CONTROL for +2.5 volt dc indication on multimeter. Disconnect TS-352B/U.	
	c. Connect AN/USM-281A to APC test point on transmitter IF and audio module.	
	d. Set AN/USM-281A for slow dot trace across crt, and adjust triggering so trace is triggered when ALC switch is operated to OFF.	

Table 4-4. Transmitter IF and Audio Module 1A5, Proof of Performance Tests—Continued

Step	Operation of test equipment	Performance standard
		+500
	e. While operating ALC switch from ON to OFF, observe dc voltage level on AN/USM-281A and determine time required for voltage to drop to 0.5 vdc, as indicated by crt trace.	2,000 ms -600
	f. Connect TS-352B/U to PPC test point on transmitter IF and audio module.	
	g. Repeat steps a and b above.	
	h. Disconnect AN/USM-281A and connect it to PPC test point on transmitter IF and audio module.	
	i. While operating ALC switch from ON to OFF, observe AN/USM-281A and determine time required for voltage to drop to 0.5 vdc, as indicated by crt trace.	300 ±100 ms
	j. On tray A2, set TEST SELECTOR switch to 3, APC-PPC SEL switch to PPC, and ALC switch to OFF.	
	k. Disconnect AN/USM-281A and connect TS-352B/U to tray A2, HI and LO jacks for reading voltage.	
	l. Adjust tray A2, ALC APC PPC POWER CONTROL for +2.4 volt dc indication on TS-352B/U.	
	m. Set tray A2 TEST SELECTOR switch to 2.	
	n. Disconnect TS-352B/U and connect it to measure current at tray A2, HI and LO jacks: positive lead to HI jack, and negative lead to LO jack.	50 ±15 ua
	o. Disconnect TS-352B/U.	
15	Output:	
	a. Set test set KEY switch to OFF, and IF OSCILLATOR switch to 1+2.	
	b. Set tray A2, ALC switch and APC-PPC SEL switch to OFF; set AGC SYNC switch to ON.	
	c. Connect AN/USM-306 to test set TWO TONE OUT connector and adjust 1.7515 level for output of -47 dbm with TWO TONE control 1/4 turn cw for full cw, as indicated by AN/USM-306.	
	d. Disconnect AN/USM-306 (unterminated BRDG-50 Ω) and connect it to tray A2 COMMON section IF OUT connector. Observe AN/USM-306 indication.	35 ±10 mv rms, -19 to -14.0 dbm.
	e. Disconnect AN/USM-306.	
16	Im Distortion:	
	a. Set test set TWO TONE SELECTOR switch to 1+3.	
	b. Connect AN/USM-306 to test set TWO TONE OUT connector and adjust 1.7525 level for output of -47 dbm as indicated by AN/USM-306.	
	c. Disconnect AN/USM-306 and connect it to tray A2 COMMON section IF OUT connector.	
	d. Set tray A2, APC-PPC SEL switch to APC and adjust ALC APC PPC POWER CONTROL for -27 dbm indication on AN/USM-306.	
	e. Set test set TWO TONE SELECTOR switch to 2+3.	
	f. Note Im level with respect to 10 mv rms tone output established in step e above.	Im at least 55 db below 10 mv rms reference.
17	Carrier Leakage:	
	a. Set TWO TONE SELECTOR to 1+3 and TWO TONE control one-quarter of its full range.	
	b. Connect AN/USM-306 to 1.75 MHz OSC output connector on test set.	
	c. Adjust 1.75 level for output of -13 dbm.	
	d. Disconnect AN/USM-306 voltmeter and connect it to tray A2 COMMON section IF OUT connector.	
	e. Set SERV SEL switch to AM.	
	f. Adjust tray A2, ALC APC PPC POWER CONTROL for -37.25 dbm indication on AN/USM-306.	
	g. Set test set TWO TONE SELECTOR switch to 4.	
	h. Set test set SERV SEL switch to each of the following modes, and observe 1.75 MHz carrier level with respect to level of 1.7515 MHz signal as indicated by AN/USM-306:	1.75 MHz carrier at least 35 db below level of 1.7515 MHz signal for each mode (F, fig. 4-3).
	SSB/NSK	
	FSK	
	CW	

Table 4-4. Transmitter IF and Audio Module 1A5, Proof of Performance Tests—Continued

Step	Operation of test equipment	Performance standard
	i. Set tray A2 APC-PPC SEL switch to OFF and repeat step h above.	
	j. Disconnect AN/USM-306.	
18	CW Switch Positions:	
	a. Set test set SERV SEL switch to CW.	
	b. Connect AN/USM-281A to AN/URM-127 output.	
	c. Adjust AN/URM-127 for frequency of 1 kHz and output level of 5 v pp (no load) and connect test set to PULSE GENERATOR INPUT. Disconnect AN/USM-281A.	
	d. Connect AN/USM-281A to the test set PULSE GENERATOR OUTPUTS 1, and adjust PULSE GENERATOR WIDTH and AMPLITUDE controls for OUTPUTS to obtain pulse width of 85 μsec and pulse amplitude of 1 v. Disconnect AN/USM-281A.	G, figure 4-3
	e. Connect test set PULSE GENERATOR OUTPUTS 1 to tray A2 INPUT kHz PULSE connector using cable W1.	
	f. Connect TS-723(*)/U to tray A2 AUDIO OUT connector and observe indication at 2 kHz. Record db level.	8 ± 4 mv rms
	g. Observe level of harmonic content at 4 kHz with respect to recorded level of signal at 2 kHz.	Harmonic at 4 kHz down at least 35 db from 2 kHz signal level.
	h. Disconnect all test equipment.	

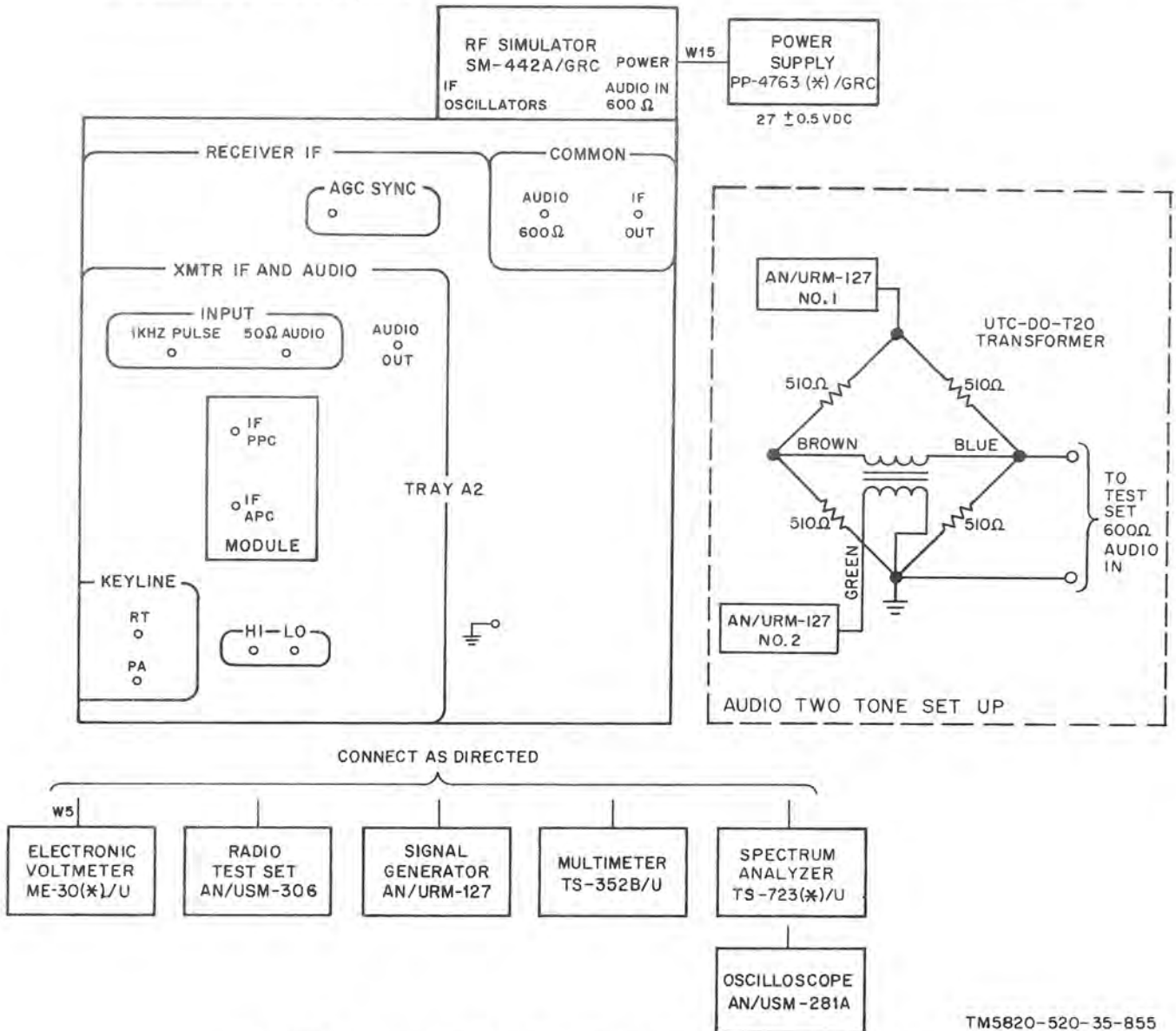

Figure 4-5. Transmitter IF and audio module 1A5, performance test setup.

Table 4-5. Frequency Dividers Module 1A6, Proof of Performance Tests

(Refer to figure 4-6.)

Step	Operation of test equipment	Performance standard
1	<p>Voltage Checks:</p> <ul style="list-style-type: none"> a. Refer to TM 11-6625-847-12 for preliminary control settings of test set and tray A3. b. On the test set, set the PA-RT switch to RT and the SERV SEL switch to STBY. c. Set tray A3 end panel MODULE SELECT switch to FREQ DIV, and amplifier switches to their OFF positions. d. Turn on all equipment. 	
	NOTE	
	<ul style="list-style-type: none"> 1. For test points and test equipment connections, refer to figure 4-6. 2. All tray A3 control panel designations used throughout these module tests refer to FREQ DIVIDER section unless otherwise specified. 	
	<ul style="list-style-type: none"> e. Connect TS-352B/U to tray A3 POWER section FIXED test point and observe TS-352B/U indication. Adjust test set DC VOLTAGE 20 control if necessary. 	±19.5 vdc
	<ul style="list-style-type: none"> f. Disconnect TS-352B/U. 	
	<ul style="list-style-type: none"> g. Set tray A3 POWER section VAR-FIXED switch to VAR. 	
	<ul style="list-style-type: none"> h. Connect TS-352B/U to tray A3 POWER section VAR test point and observe TS-352B/U indication. Adjust tray A3 POWER section ADJ control if necessary. 	±19.5 ±0.2 vdc
	<ul style="list-style-type: none"> i. Disconnect TS-352B/U. 	
	NOTE	
	<p>To insure accuracy of frequency standards, allow 1-hour warmup time for frequency standard module and frequency measurement equipment.</p>	
	<ul style="list-style-type: none"> j. Connect AN/URM-145 to 500 kHz test point on frequency standard module. Observe AN/URM-145 indication. 	220 ±30 mv rms
	<ul style="list-style-type: none"> k. Disconnect AN/URM-145. 	
	<ul style="list-style-type: none"> l. Connect AN/USM-207 to 500 kHz OUT test point on frequency standard module. Observe AN/USM-207 indication. 	500 kHz ±10 Hz
	<ul style="list-style-type: none"> m. Disconnect AN/USM-207. 	
2	<p>1 kHz Pulse Lock Test:</p> <ul style="list-style-type: none"> a. Check to see that INT-EXT switch on frequency standard module is set to INT. b. Connect AN/USM-207 to tray A3 1 kHz PULSE connector. Observe AN/USM-207 indication. c. Set IN-EXT switch on frequency standard module to EXT. Observe AN/USM-207 indication. d. Set INT-EXT switch on frequency standard module to INT. e. Disconnect AN/USM-207. 	1 kHz ±1 Hz
		Frequency is near 1 kHz but not exact as in step <i>b</i> above.
3	<p>10 kHz Spectrum Lock Test:</p> <ul style="list-style-type: none"> a. Connect AN/USM-281A to tray A3, 10 kHz SPECTRUM connector and observe pulse-type waveform. b. Set INT-EXT switch on frequency standard module to EXT and then to INT while observing AN/USM-281. Note that frequency shifts when switching. c. Set INT-EXT switch on frequency standard module to INT and disconnect AN/USM-281A. 	10 kHz pulse repetition rate (H, fig. 4-3).
4	<p>100 kHz Spectrum Lock Test:</p> <ul style="list-style-type: none"> a. Connect AN/USM-281A to tray A3, 100 kHz SPECTRUM connector. Note that with frequency standard module INT-EXT switch set to INT a waveform is displayed on the AN/USM-281A. b. Set INT-EXT switch on frequency standard module to EXT while observing AN/USM-281A. c. Set INT-EXT switch on frequency standard module to INT and disconnect AN/USM-281A. 	Approx 2 v pp (I, fig. 4-3).
		Waveform disappears.
		Waveform of step 5a reappears.

Table 4-5. Frequency Dividers Module 1A6, Proof of Performance Tests—Continued

Step	Operation of test equipment	Performance standard
5	Frequency Shift Test: a. Connect AN/USM-207 to tray A3, 10 and 1 kHz SYNTH section 7.1 MHz connector. Note AN/USM-207 indication. b. Verify step 1e above. c. Set tray A3 FREQ SHIFT switch to 0, then to + ΔF , and then to - ΔF . Observe AN/USM-207 indication at each position.	19.5 vdc 0: Frequency count within ± 20 Hz of frequency noted in step a above. + ΔF : Frequency count is 400 to 700 Hz greater than for 0 position. - ΔF : Frequency count is 400 to 700 Hz less than for 0 position.
	d. Set tray A3 FREQ SHIFT switch to OFF and disconnect AN/USM-207.	
6	1.75 MHz Output Test: a. Connect AN/USM-306 and 50 ohm termination to tray A3, 1.75 MHz connector. b. Adjust AN/USM-306 (termination 50 ohms) to 1.75 MHz signal and note indication.	40 to 60 mv rms, -15 to -11.5 dbm.
7	500 kHz Spurious Test of 1.75 MHz: a. Adjust AN/USM-306 (termination 50 ohms) tuning to observe 1.800 MHz signal level. b. Disconnect 50 ohm load.	Less than 0.5 mv rms, -53 dbm.
8	100 kHz Spectrum Output Test: a. Disconnect AN/USM-306 (bridging 50 ohms) and connect it to tray A3, 100 kHz SPECTRUM connector. b. Adjust AN/USM-306 tuning to observe signal level of each frequency listed below: 15.3 MHz 15.4 MHz 15.5 MHz 15.6 MHz 15.7 MHz 15.8 MHz 15.9 MHz 16.0 MHz 16.1 MHz 16.2 MHz 16.3 MHz	Signal level at each frequency: 10 to 30 mv rms -28.5 to -19 dbm
9	10 kHz Spectrum Output Test: a. Disconnect AN/USM-306 and connect it to tray A3, 10 kHz SPECTRUM connector. b. Adjust AN/USM-306 (bridging 50 ohms) tuning to observe signal level of each frequency listed below: 2.48 MHz 2.49 MHz 2.50 MHz 2.51 MHz 2.52 MHz 2.53 MHz 2.54 MHz 2.55 MHz 2.56 MHz 2.57 MHz c. Disconnect AN/USM-306.	Signal level at each frequency: 1.4 to 3.8 mv rms -44 to -35.5 dbm
10	1 kHz Spectrum Output Test: a. Connect TS-723(*)/U to 1 kHz PULSE OUPPT test test point on frequency dividers module. b. Adjust TS-723(*)/U tuning to observe signal level of each frequency listed below: 21 kHz 22 kHz	Signal level at each frequency: 7 to 13 mv rms -30 to 24.5 dbm

Table 4-5. Frequency Dividers Module 1A6, Proof of Performance Tests—Continued

Step	Operation of test equipment	Performance standard
	23 kHz	
	24 kHz	
	25 kHz	
	26 kHz	
	27 kHz	
	28 kHz	
	29 kHz	
	30 kHz	
c.	Disconnect TS-723(*)/U and connect it to tray A3, 1 kHz PULSE connector.	
d.	Adjust TS-723(*)/U tuning to observe level of 2 kHz signal.	105 to 155 mv rms -7 to -3.5 dbm
e.	Disconnect all test equipment.	

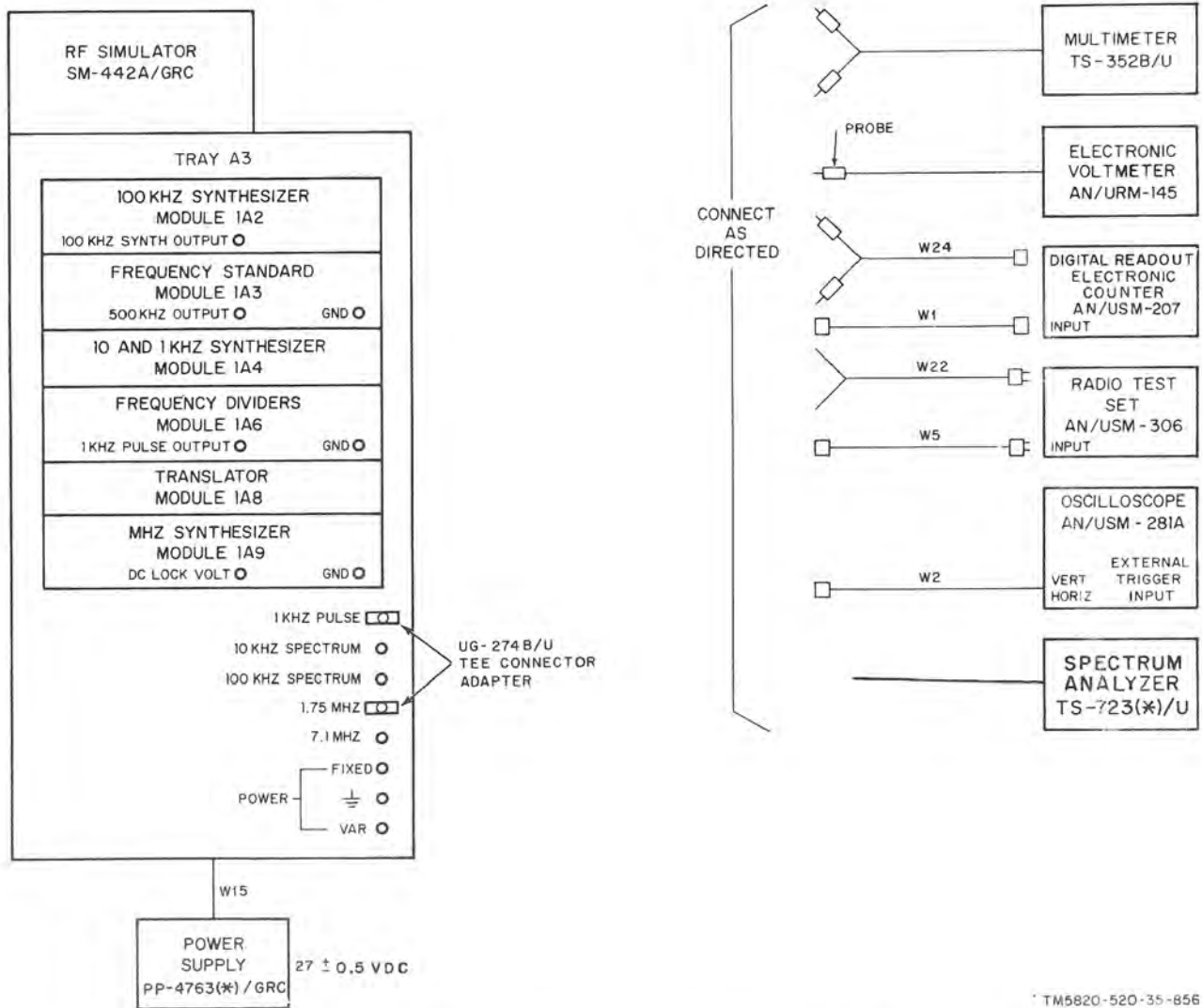

Figure 4-6. Frequency dividers module 1A6 performance test setup.

TM5820-520-35-856

Table 4-6. Receiver IF Module 1A7, Proof of Performance Tests

(Refer to figure 4-7.)

<i>Step</i>	<i>Operation of test equipment</i>	<i>Performance standard</i>
1	<p>Voltage Checks:</p> <ul style="list-style-type: none"> a. Refer to TM 11-6625-847-12 for preliminary control settings on test set and tray A2. b. On test set, set SERV SEL switch to SSB/NSK, PA-RT switch to RT, REC-XMIT switch to REC, and Two Tone Selector to 4. c. Set tray A2, RCVR IF section AGC-SYNC switch to ON. d. Turn on all equipment. <p style="text-align: center;">NOTE</p> <ul style="list-style-type: none"> 1. For test points and test equipment connections, refer to figure 4-7. 2. All tray A2 control panel designations used throughout these module tests refer to RCVR IF section unless otherwise specified. <ul style="list-style-type: none"> e. Connect TS-352B/U positive lead to tray A2 HI jack and negative lead to LO jack, with TEST SELECTOR switch set to 1. -32 ± 2 vdc f. Set tray A2 XMIT IF AND AUDIO section TEST SELECTOR switch to 1. g. Disconnect TS-352B/U and connect it to tray 2 XMTR IF AND AUDIO section positive lead to HI jack, and negative lead to LO jack. h. Adjust test set DC VOLTAGE 20 control for +19.5 volt indication on TS-352B/U. +19.5 vdc i. Set tray A2 TEST SELECTOR switch to 2. j. Disconnect TS-352B/U and connect positive lead to tray A2 HI jack and negative lead to LO jack. k. Adjust tray A2 RF GAIN control for +0.5 volt dc indication on TS-352B/U. l. Disconnect TS-352B/U. <p style="text-align: center;">NOTE</p> <p>To insure accuracy of frequency standards, allow 1-hour warmup time for the AN/USM-306 and 1-hour warmup time for the two-tone setup.</p>	
2	<p>IF Output:</p> <ul style="list-style-type: none"> a. Set test-set two tone selector switch to 1. b. Connect AN/USM-306 (terminated in 50 ohms) to test set IF OSCILLATORS 1.75 MHz OUT connector and adjust 1.75 level for -12.8 dbm output as indicated by AN/USM-306. c. Set test set two tone selector switch to 1+3. d. Disconnect AN/USM-306 and connect it to test set IF OSCILLATORS TWO TONE OUT connector and adjust 1.7525 level for -47 dbm. e. Set test set XMIT-STATUS switch to TUNE. f. Set tray A2 RF-AGC switch to ON. g. Disconnect AN/USM-306 and connect it to tray A2 COMMON section IF OUT connector. h. Observe AN/USM-306 indication. i. Observe carrier (1.75 MHz) level and any bfo leakage with respect to level of 1.7525 MHz signal. 24 ± 3 mv rms -20.5 to 18.2 dbm Carrier and any bfo leakage at least 35 db below level of 1.7525 MHz signal. (J, fig. 4-3). j. Disconnect AN/USM-306. k. Set tray A2 TEST SELECTOR switch to 4. l. Connect ME-30(*)/U to tray A2 HI and LO jacks and observe indication at 2.5 kHz. 750 ± 150 mv rms m. Disconnect ME-30(*)/U. 	
8	<p>Im Distortion:</p> <ul style="list-style-type: none"> a. Set two tone selector switch to 1+3. Connect AN/USM-306 (terminated in 50 ohms) to test set IF OSCILLATORS TWO TONE OUT connector and adjust 1.7535 level for -33 dbm output as indicated by AN/USM-306. b. Set test set TWO TONE SELECTOR switch to 1+2. 	

Table 4-6. Receiver IF Module 1A7, Proof of Performance Tests—Continued

Step	Operation of test equipment	Performance standard
	<ul style="list-style-type: none"> c. Adjust test set 1.7515 level for -33 dbm as indicated by AN/USM-306. Disconnect AN/USM-306. d. Set test set TWO TONE SELECTOR switch to 4. e. Connect TS-723(*)/U to tray A2 HI and LO jacks and observe Im distortion in reference tones of 1.5 ± 2.5 kHz. f. Disconnect TS-723(*)/U. 	Im distortion at least 40 db below either tone.
4	<p>Agc:</p> <ul style="list-style-type: none"> a. Set tray A2 AGC SYNC switch to ON. Set test set TWO TONE SELECTOR switch to 1+3. b. Connect AN/USM-306 to test set IF OSCILLATORS TWO TONE OUT connector and adjust 1.7525 level for -51.5 dbm output as indicated by AN/USM-306. c. Set tray A2 AGC SYNC switch to OFF. d. Connect AN/GRM-50 output to test set TWO TONE IN connector. e. Adjust AN/GRM-50 for 1.7525 MHz frequency (as indicated by peak of AN/USM-306 and output level of 20 mv rms). f. Connect AN/USM-281A external trigger to tray A2 AGC SYNC test point. 	
	NOTE	
	In steps <i>h</i> and <i>j</i> below, AN/USM-281A triggering should be adjusted so that sweep starts when AGC SYNC switch is operated.	
	<ul style="list-style-type: none"> g. Connect AN/USM-281A to AGC RF test point on receiver IF module. h. Adjust AN/USM-281A to display approximately 20 volt/cm signal with 100 ms/cm sweep. i. Operate tray A2 AGC SYNC switch from OFF to ON and observe hang-time. j. Adjust AN/USM-281A to display 20 volt/cm signal with 5 ms/cm sweep. k. Operate tray A2 AGC SYNC switch from ON to OFF and observe attack time. l. Set tray A2 AGC SYNC switch to OFF. Disconnect AN/USM-281A and decrease output level of 1.7525 MHz signal from AN/GRM-50 to -26.5 dbm as indicated by AN/USM-306. m. Connect ME-30(*)/U to tray A2 HI and LO jacks. n. Observe ME-30(*)/U indication at 2.5 kHz while operating tray A2 AGC SYNC switch from OFF to ON. o. Disconnect ME-30(*)/U and AN/GRM-50. p. Adjust test set 1.7525 level for -27 dbm output as indicated by AN/USM-306 (termination 50 ohms). q. Disconnect AN/USM-306. r. Connect TS-352B/U to tray A2 RF AGC OUTPUT test points on the module for measuring negative voltage; observe TS-352B/U indication. s. Set tray A2 TEST SELECTOR switch to 2 and set RF GAIN control for 0.5 v. 	<p>k, figure 4-3</p> <p>L, figure 4-3</p>
	<ul style="list-style-type: none"> t. Set tray A2 AGC SYNC switch to OFF and observe TS-352B/U indication. u. Disconnect TS-352B/U and connect it to tray A2 HI and LO jacks for measuring positive voltage. v. Adjust tray A2 RF GAIN control for +1.8 volt dc indication on TS-352B/U. Disconnect TS-352B/U. w. Set tray A2 TEST SELECTOR switch to 5. x. Connect TS-352B/U for measuring current at tray A2 HI (positive lead) and LO (negative lead) jacks; note that TS-352B/U indication is approximately 100 μa. y. Repeat steps <i>u</i> through <i>x</i> above but adjust RF GAIN control (step <i>v</i>) for +0.5 vdc; note that TS-352B/U indication has decreased to very low level. z. Disconnect TS-352B/U. 	<p>Signal level decreases not more than 5 db after stabilization.</p> <p>-24 vdc or more negative.</p> <p>+0.3 0 vdc -0</p> <p>For RF GAIN control range of +0.5 vdc up to +1.8 vdc at HI-LO jacks, current range is 0 to 100 μa.</p>

Table 4-6. Receiver IF Module 1A7, Proof of Performance Tests—Continued

Step	Operation of test equipment	Performance standard
5	<p>IF Bandwidth:</p> <ol style="list-style-type: none"> Set tray A2 RF AGC and AGC SYNC switches to OFF. Rotate four test set IF OSCILLATORS control fully counterclockwise. Connect AN/GRM-50 (fig. 4-7) output lead to test set TWO TONE IN connector in IF OSCILLATORS section. Connect AN/USM-306 (terminated in 50 ohms) to test set TWO TONE OUT connector. Connect AN/URM-145 to tray A2 COMMON section IF OUT connector. Adjust AN/GRM-50 for 1750.4 kHz frequency (as indicated by AN/USM-207) at -47 dbm output level (as indicated on AN/USM-306). Record db indication of AN/URM-145. Adjust AN/GRM-50 for 1753.4 kHz frequency and observe dc indication on AN/URM-145. Adjust AN/GRM-50 for 1750.3 kHz frequency and record db indication of AN/URM-145. Adjust AN/GRM-50 for 1753.5 kHz frequency and observe dc indication on AN/URM-145. Adjust AN/GRM-50 while observing AN/URM-145 for peak indication. Record db level of peak indication. Adjust AN/GRM-50 for 1750.0 kHz frequency and observe db indication on AN/URM-145. Disconnect AN/URM-145 and connect AN/USM-306. Adjust AN/GRM-50 for 1749.7 kHz frequency and observe dc indication on AN/USM-306. Adjust AN/GRM-50 for 1754.5 kHz frequency and observe db indication on AN/USM-306. Disconnect AN/USM-306 and equipment shown in A, figure 4-7. 	<p>Output within 1.5 db of level recorded in step <i>g</i> above.</p> <p>Output within 2.0 db of level recorded in step <i>i</i> above.</p> <p>Output down at least 30 db from peak db level recorded in step <i>k</i> above.</p> <p>Output down at least 60 db from peak db level recorded in step <i>k</i> above.</p> <p>Output down at least 60 db from peak db level recorded in step <i>k</i> above.</p>
6	<p>BFO:</p> <ol style="list-style-type: none"> Set test set SERV SEL switch to CW and two tone selector switch to 1+3. Set tray A2 AGC SYNC switch to ON. Connect AN/USM-306 (terminated in 50 ohms) to test set IF OSCILLATORS TWO TONE OUT connector and adjust 1.7525 level for -47 dbm output. Set tray A2 TEST SELECTOR switch to 4. Connect AN/USM-207 to tray A2 HI and LO jack. Rotate tray A2 BFO TONE control fully counterclockwise and observe indication on AN/USM-207. Adjust tray A2 BFO TONE control for AN/USM-207 2,500 Hz indication; leave control at this setting while disconnecting AN/USM-207 and connecting ME-30(*)/U in its place. Operate RF-AGC switch to ON and observe indication on ME-30(*)/U. Disconnect ME-30(*)/U. 	<p>4,500 ± 1,000 Hz</p> <p>750 ± 150 mv rms</p>
7	<p>Transmit Tests:</p> <ol style="list-style-type: none"> Set test set XMIT-STATUS switch to OPR. Set tray A2 AGC-SYNC switch to OFF. On test set, set SERV SEL switch to SSB/NSK and REC-XMIT switch to XMIT. Connect AN/URM-127 to tray A2 COMMON section AUDIO 600 Ω IN connector and ME-30(*)/U to AN/URM-127 input. Adjust AN/URM-127 for 1 kHz frequency at output of -29 dbm. Set test set TWO-TONE SELECTOR switch to 1. Connect AN/USM-306 (bridging 50 ohms) to test set IF OSCILLATORS 1.75 MHz OUT connector and adjust 1.75 level for -13 dbm output. Disconnect AN/USM-306 and connect it to SSB FILT OUTPUT on receiver IF module and observe indication. Set test set XMIT-STATUS switch to TUNE and observe that indication on AN/USM-306 decreases. Disconnect AN/USM-306. 	<p>1 ± 0.2 mv rms, -49 to -45 dbm.</p>

Table 4-6. Receiver IF Module 1A7, Proof of Performance Tests—Continued

Step

Operation of test equipment

Performance standard

- j. Set test set XMIT-STATUS switch to OPR.
- k. Connect AN/USM-306 to tray A2 AMPLE IF OUT. Measure carrier rejection. Disconnect AN/USM-306.
- l. Disconnect AN/URM-127.
- m. Connect two-tone setup to tray A2 COMMON section AUDIO 600 Ω IN connector.
- n. Connector AN/USM-306 to receiver IF module SSB FILT OUTPUT.
- o. Set audio oscillator No. 1 for 1,500 Hz at -50 dbm, and audio oscillator No. 2 for 2,500 Hz at -50 dbm as measured separately on the AN/USM-306.
- p. Set two-tone audio output to 1+2.
- q. Connect AN/USM-306 to tray A2 AMPL IF OUT connector and measure opposite sideband rejection.
- r. Observe AN/USM-306 and measure intermodulation of 1,500 Hz and 2,500 Hz tones.
- s. Disconnect all test equipment.

Carrier to be 55 db below the reference tone level with 600 ohm balanced input and no test equipment connected to audio input (M, fig. 4-3).

Opposite sideband rejection greater than 60 db below reference low level.
Im at least 50 db below reference tone level.

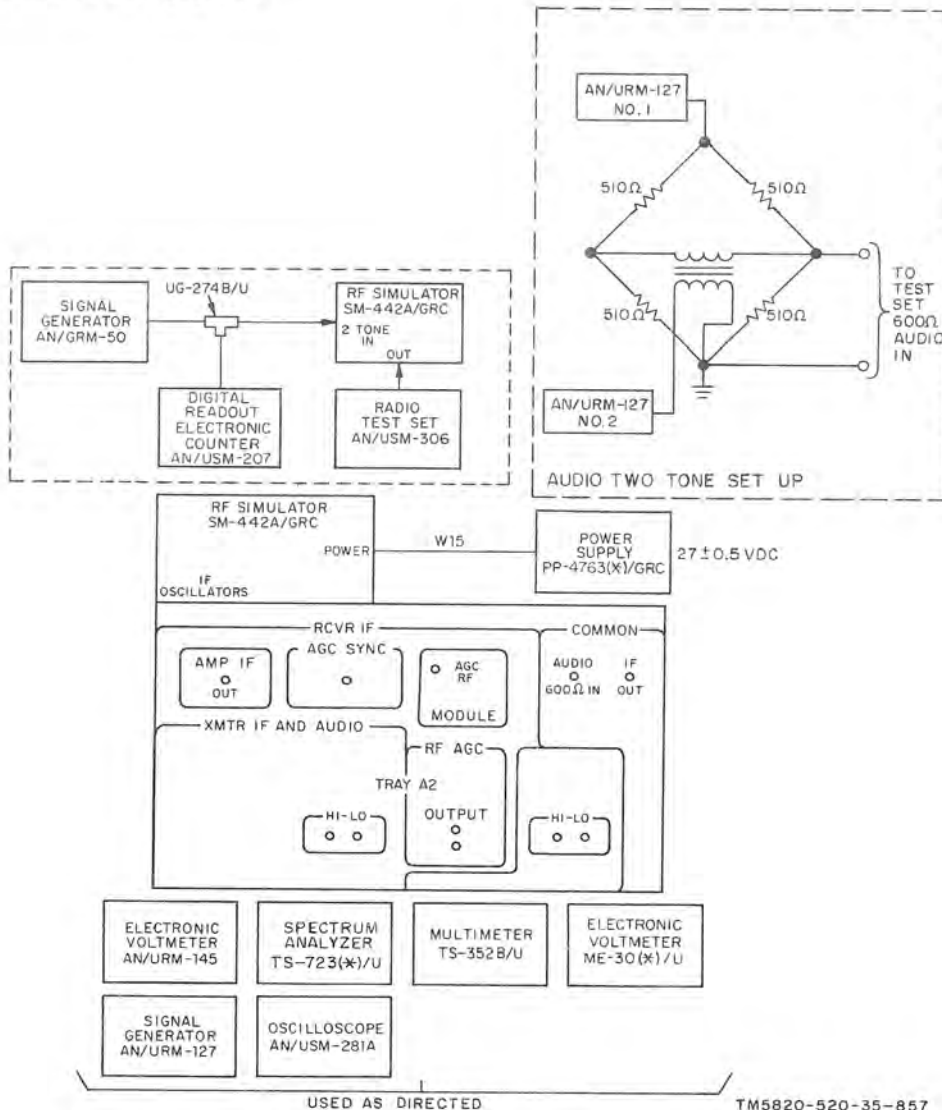

Figure 4-7. Receiver IF module 1A7, performance test setup.

Table 4-7. MHz Synthesizer Module 1A9, Proof of Performance Tests

(Refer to figure 4-8.)

Step	Operation of test equipment	Performance standard
1	<p>Voltage Checks:</p> <ul style="list-style-type: none"> a. Refer to TM-11-6625-847-12 for preliminary control settings on test set and tray A3. b. On test set, set PA-RT switch to RT and SERV SEL switch to STBY. c. Set tray A3 end panel MODULE SELECT switch to MHz SYNTH. d. Turn on all equipment. 	

NOTE

- 1. For test points and test equipment connections, refer to figure 4-8.
- 2. All tray A3 control panel designations used throughout these module tests refer to MHz SYNTH section unless otherwise specified.
- e. Connect TS-352B/U to tray A3 POWER section INPUTS FIXED test point. Observe TS-352B/U indication. Adjust test set DC VOLTAGE 20 control if necessary. +20 ±0.5 vdc.
- f. Disconnect TS-352B/U.
- g. Set tray A3 POWER section VAR-FIXED switch to VAR.
- h. Connect TS-352B/U to tray A3 POWER section INPUTS VAR test point. Observe indication. Adjust tray A3 POWER section ADJ control if necessary. +19.5 ±0.5 vdc
- i. Disconnect TS-352B/U.

NOTE

To insure accuracy of frequency standards, allow 1-hour warm-up time for frequency standard module and frequency measurement equipment.

- 2 MHz Synthesizer Output Test:
 - a. Connect AN/URM-145 to tray A3 FREQ STANDARD section 1 MHz connector.
 - b. Set tray A3 FREQ STANDARD section 1 MHz AMPL ON/OFF switch to ON.
 - c. Adjust tray A3 FREQ STANDARD section 1 MHz OUTPUT VOLT ADJ control for 400 mv rms indication of AN/URM-145.
 - d. Set MC SYNTH OUTPUT AMPL VOLT ADJ control to maximum counterclockwise position and AMPL ON-OFF switch to ON position. Connect a 91 ohm, 1/2 watt, noninductive resistor between MC SYNTH OUTPUT test point 1A9A3J1 and GRD on module under test. Disconnect AN/URM-145 and connect it across the 91 ohm resistor.
 - e. Set test set MHz FREQ controls as listed below, and observe AN/URM-145 indication for each frequency setting:

MHz FREQ		
10 MHz	1 MHz	.1 MHz
0	-----2-----	0
0	-----3-----	0
0	-----4-----	0
0	-----5-----	0
0	-----6-----	0
0	-----7-----	0
0	-----8-----	0
0	-----9-----	0
1	-----0-----	0
1	-----1-----	0
1	-----2-----	0
1	-----3-----	0
1	-----4-----	0
1	-----5-----	0
1	-----6-----	0

60 ±20 mv rms, across 50 ohm load.

Table 4-7. MHz Synthesizer Module 1A9, Proof of Performance Tests—Continued

Step	Operation of test equipment	Performance standard																																													
	<table border="0" style="margin-left: auto; margin-right: auto;"> <thead> <tr> <th colspan="3" style="text-align: center;">MHz FREQ</th> </tr> <tr> <th style="text-align: left;">10 MHz</th> <th style="text-align: center;">1 MHz</th> <th style="text-align: right;">.1 MHz</th> </tr> </thead> <tr><td>1-----</td><td>7-----</td><td>0</td></tr> <tr><td>1-----</td><td>8-----</td><td>0</td></tr> <tr><td>1-----</td><td>9-----</td><td>0</td></tr> <tr><td>2-----</td><td>0-----</td><td>0</td></tr> <tr><td>2-----</td><td>1-----</td><td>0</td></tr> <tr><td>2-----</td><td>2-----</td><td>0</td></tr> <tr><td>2-----</td><td>3-----</td><td>0</td></tr> <tr><td>2-----</td><td>4-----</td><td>0</td></tr> <tr><td>2-----</td><td>5-----</td><td>0</td></tr> <tr><td>2-----</td><td>6-----</td><td>0</td></tr> <tr><td>2-----</td><td>7-----</td><td>0</td></tr> <tr><td>2-----</td><td>8-----</td><td>0</td></tr> <tr><td>2-----</td><td>9-----</td><td>0</td></tr> </table>	MHz FREQ			10 MHz	1 MHz	.1 MHz	1-----	7-----	0	1-----	8-----	0	1-----	9-----	0	2-----	0-----	0	2-----	1-----	0	2-----	2-----	0	2-----	3-----	0	2-----	4-----	0	2-----	5-----	0	2-----	6-----	0	2-----	7-----	0	2-----	8-----	0	2-----	9-----	0	
MHz FREQ																																															
10 MHz	1 MHz	.1 MHz																																													
1-----	7-----	0																																													
1-----	8-----	0																																													
1-----	9-----	0																																													
2-----	0-----	0																																													
2-----	1-----	0																																													
2-----	2-----	0																																													
2-----	3-----	0																																													
2-----	4-----	0																																													
2-----	5-----	0																																													
2-----	6-----	0																																													
2-----	7-----	0																																													
2-----	8-----	0																																													
2-----	9-----	0																																													
	f. Disconnect AN/URM-145.																																														
3	MHz Synthesizer Frequency, Lock, and HI-LO Test:																																														
	a. Connect AN/USM-207 (with video amplifier plug-in installed) to tray A3 MHz SYNTH connector.																																														
	b. On MHz synthesizer module 1A9, connect TS-352B/U for measuring ±17 vdc: positive lead to DC LOCK VOLT test point, and common lead to GND test point.																																														
	c. Set test set MHz FREQ controls as listed below and observe TS-352B/U indication, AN/USM-207 indication, and tray A3 HI and LO lamps for each frequency setting.	Dc lock voltage (TS-352B/U): +8 to +17 vdc for all frequency settings.																																													

10 MHz	MHz FREQ		1 MHz	Frequency (MHz ±1 Hz)	Lamp	
	1 MHz	.1 MHz			HI	LO
0-----	2-----	0-----	0-----	17.5	off	on
0-----	3-----	0-----	0-----	16.5	off	on
0-----	4-----	0-----	0-----	15.5	off	on
0-----	5-----	0-----	0-----	14.5	off	on
0-----	6-----	0-----	0-----	23.5	on	off
0-----	7-----	0-----	0-----	12.5	off	on
0-----	8-----	0-----	0-----	11.5	off	on
0-----	9-----	0-----	0-----	20.5	on	off
1-----	0-----	0-----	0-----	19.5	on	off
1-----	1-----	0-----	0-----	8.5	off	on
1-----	2-----	0-----	0-----	7.5	off	on
1-----	3-----	0-----	0-----	16.5	on	off
1-----	4-----	0-----	0-----	5.5	off	on
1-----	5-----	0-----	0-----	4.5	off	on
1-----	6-----	0-----	0-----	3.5	off	on
1-----	7-----	0-----	0-----	12.5	on	off
1-----	8-----	0-----	0-----	11.5	on	off
1-----	9-----	0-----	0-----	10.5	on	off
2-----	0-----	0-----	0-----	9.5	on	off
2-----	1-----	0-----	0-----	8.5	on	off
2-----	2-----	0-----	0-----	2.5	off	on
2-----	3-----	0-----	0-----	3.5	off	on
2-----	4-----	0-----	0-----	5.5	on	off
2-----	5-----	0-----	0-----	4.5	on	off
2-----	6-----	0-----	0-----	3.5	on	off
2-----	7-----	0-----	0-----	7.5	off	on
2-----	8-----	0-----	0-----	8.5	off	on
2-----	9-----	0-----	0-----	9.5	off	on

- d. Disconnect AN/USM-207 and TS-352B/U.
- 4 MHz Synthesizer Output Spurious Test:
- a. Set test set 10 MHz frequency control to 1, and 1 MHz FREQ control to 6.

Table 4-7. MHz Synthesizer Module 1A9, Proof of Performance Tests—Continued

Step	Operation of test equipment	Performance standard																				
b.	Connect AN/URM-145 to tray A3 FREQ STANDARD section 1 MHz connector.																					
c.	Adjust tray A3 FREQ STANDARD section 1 MHz OUTPUT VOLT ADJ control for 600 mv rms indication on AN/URM-145.																					
d.	Disconnect AN/URM-145.																					
e.	Connect AN/USM-306 (terminated in 50 ohms) to tray A3 MHz SYNTH connector.																					
f.	Set test set MHz FREQ controls to each of the three frequencies listed below. On AN/USM-306 observe db level of each output frequency (3.5 MHz, 10.5 MHz, and 9.5 MHz) and compare it with db level of corresponding spurious signal listed. (Note there are two spurious signals to check at 9.5 MHz setting.)																					
	<table border="1"> <thead> <tr> <th colspan="2">MHz FREQ</th> <th>Main output frequency</th> <th>Spurious frequency</th> </tr> </thead> <tbody> <tr> <td>1</td> <td>-----6-----0-----</td> <td>3.5 MHz</td> <td>24.5 MHz</td> </tr> <tr> <td>1</td> <td>-----9-----0-----</td> <td>10.5 MHz</td> <td>21 MHz</td> </tr> <tr> <td></td> <td></td> <td></td> <td>19 MHz</td> </tr> <tr> <td>2</td> <td>-----0-----0-----</td> <td>9.5 MHz</td> <td>28.5 MHz</td> </tr> </tbody> </table>	MHz FREQ		Main output frequency	Spurious frequency	1	-----6-----0-----	3.5 MHz	24.5 MHz	1	-----9-----0-----	10.5 MHz	21 MHz				19 MHz	2	-----0-----0-----	9.5 MHz	28.5 MHz	Greater than: 40 db down 20 db down 20 db down 30 db down
MHz FREQ		Main output frequency	Spurious frequency																			
1	-----6-----0-----	3.5 MHz	24.5 MHz																			
1	-----9-----0-----	10.5 MHz	21 MHz																			
			19 MHz																			
2	-----0-----0-----	9.5 MHz	28.5 MHz																			
g.	Disconnect all test equipment.																					

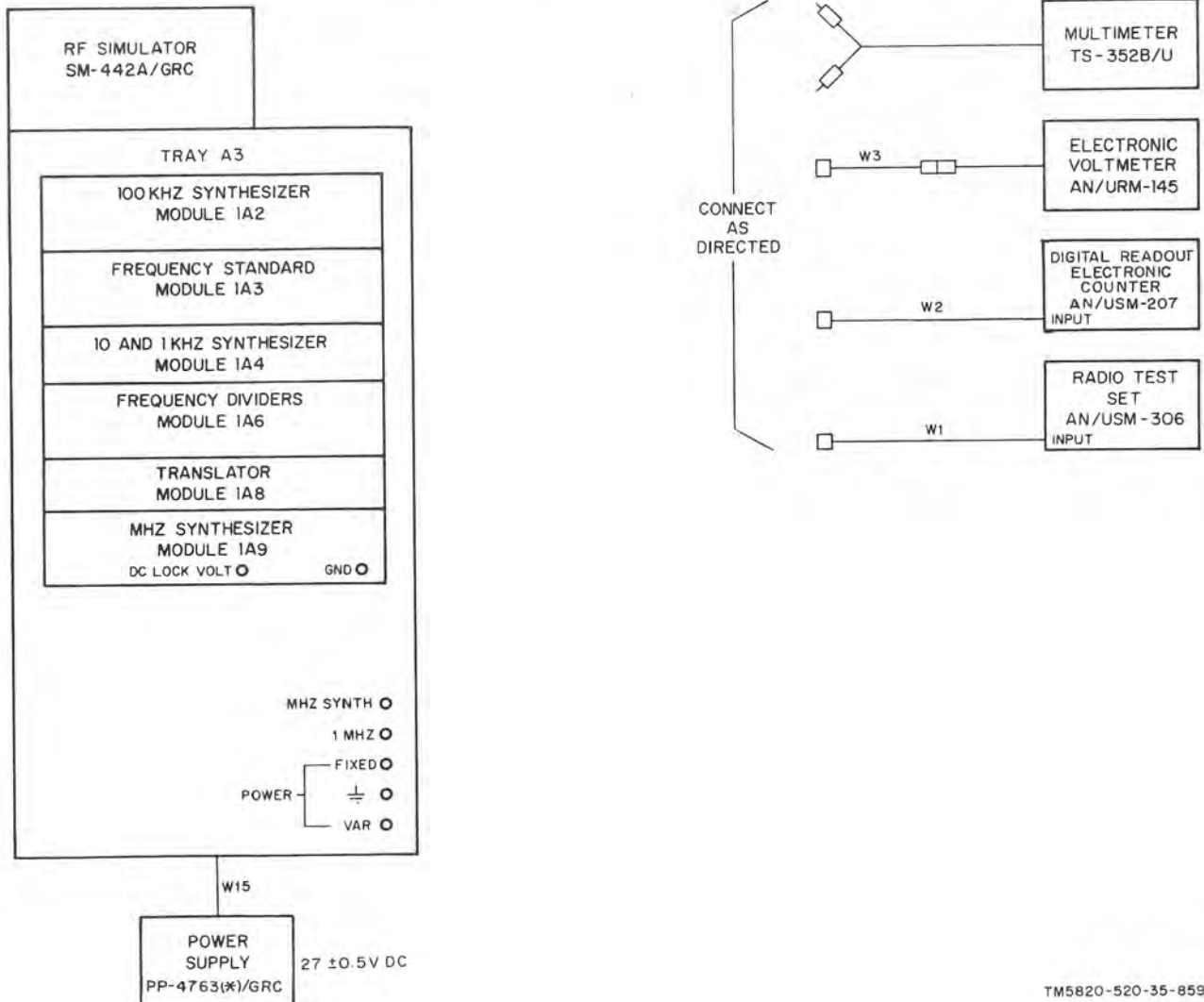

Figure 4-8. MHz synthesizer module 1A9, performance test setup.

Table 4-8. Receiver Audio Module 1A10, Proof of Performance Tests

(Refer to figure 4-9.)

Step	Operation of test equipment	Performance standard
1	<p>Voltage Check:</p> <ol style="list-style-type: none"> Refer to TM 11-6625-847-12 for preliminary control settings for test set and tray A2. Set test set SERV SEL switch to SSB/NSK and REC-XMIT switch to REC. On RCVR AUDIO section of tray A2, set SQUELCH SYNC switch to ON, and AUDIO GAIN fully clockwise. Turn on all equipment. 	
	<p>NOTE</p>	
	<ol style="list-style-type: none"> To insure accuracy of frequency standard, allow 1 hour warm-up time for the AN/URM-127. For test points and test equipment connections, refer to figure 4-9. All tray A2 control panel designations used throughout these module tests refer to RCVR AUDIO section unless otherwise specified. 	
	<ol style="list-style-type: none"> Connect ME-26(*)/U to tray A2 XMTR IF AND AUDIO section HI and LO jacks with TEST SELECTOR switch set to 1 and observe positive voltage. Adjust test set DC VOLTAGE 20 control if necessary. Disconnect ME-26(*)/U. 	<p>+19.5 ± 2 vdc</p>
2	<p>Audio Output, 10 Mw:</p> <ol style="list-style-type: none"> Connect AN/URM-127 tone output to tray A2 COMMON section AUDIO 600 Ω IN connector. Connect ME-30(*)/U input to tray A2 INPUTS AUDIO IN test point. Adjust Output Meter TS-585/U to measure 10 mv (600 Ω load) and connect it to tray A2 OUTPUTS 10 MW test point. Connect 600 ohm, 2 watt load resistor between tray A2 OUTPUTS 2 WATT and ground. Set AN/USM-127 tone for frequency of 1,100 Hz at a level of 750 mv rms as indicated by ME-30(*)/U. Record audio input level indication of TS-585/U. 	<p>Not less than 10 mv (2.45 v).</p>
3	<p>Frequency Response, 10 Mw:</p> <ol style="list-style-type: none"> Set AN/URM-127 tone frequency successively 300, 500, 1,000, and 3,500 Hz. For each frequency, adjust output amplitude to keep indication at level recorded in step 2f. Observe TS-585/U indication for each frequency setting. 	<p>Highest and lowest indications for four frequencies to be within 1 db of each other.</p>
	<ol style="list-style-type: none"> Disconnect ME-30(*)/U. 	
4	<p>Audio Output, 2 Watt:</p> <ol style="list-style-type: none"> Adjust AN/URM-127 for frequency of 1,100 Hz and output level of 750 mv rms as indicated by ME-30(*)/U. Adjust TS-585/U to measure 2 watts. Disconnect ohm load resistor and the TS-585/U and interchange them. Observe TS-585/U indication. 	<p>Not less than 2 watts (34.5 v.)</p>
5	<p>Harmonic Distortion, 2 Watts:</p> <ol style="list-style-type: none"> Adjust AN/URM-127 for 2 watt indication on TS-585/U. Disconnect TS-585/U. Connect TS-723(*)/U to tray A2 OUTPUTS 2 WATT test point. Adjust TS-723(*)/U for frequency of 1,100 Hz and rms range of 10 volts (+20 db, 100%). Observe distortion indication. Disconnect TS-723(*)/U. 	<p>Distortion not greater than 5%.</p>
6	<p>Harmonic Distortion, 10 Mw:</p> <ol style="list-style-type: none"> Adjust TS-585/U to measure 10 mw and connect it to tray A2 OUTPUTS 10 MW test point. Connect 600 Ω 2w load between tray A2 OUTPUTS 2 WATT and ground. Adjust AN/URM-127 tone output for 10 mw indication on TS-585/U. Disconnect TS-585/U. 	

Table 4-8. Receiver Audio Module 1A10, Proof of Performance Tests—Continued

Step	Operation of test equipment	Performance standard
	<ul style="list-style-type: none"> e. Connect TS-723(*)/U to tray A2 OUTPUTS 10 MW test point and observe distortion indication. f. Disconnect TS-723(*)/U. 	Distortion not greater than 1%.
7	<p>Squelch Sensitivity, 10 Mw:</p> <ul style="list-style-type: none"> a. Connect AN/URM-127 input to tray A2 INPUTS AUDIO IN test point. b. Adjust AN/URM-127 for frequency of 500 Hz. c. Set tray A2 SQUELCH switch to ON. d. Connect AN/USM-281A to tray A2 OUTPUTS 10 MW test point. e. Connect AN/USM-281A external trigger to tray A2 INPUTS SQUELCH SYNC test point. f. Set AN/URM-127 tone for frequency of 500 Hz, and adjust output level for indication of 300 mv rms on ME-30(*)/U. g. Observe AN/USM-281A trace while operating tray A2 SQUELCH switch from ON to OFF. h. Reduce AN/URM-127 level and set for 0.1 volt rms range. i. Adjust AN/URM-127 tone output for indication of 24 mv rms on ME-30(*)/U. j. Observe AN/USM-281A trace while operating tray A2 SQUELCH switch from OFF to ON. k. Disconnect AN/USM-281A signal connection, but not its trigger connection. l. Connect ME-30(*)/U to tray A2 OUTPUTS 10 MW test point. m. Set ME-30(*)/U for 0.3 volt rms range and record meter indication with tray A2 SQUELCH switch set to OFF. n. Set tray A2 SQUELCH switch to ON. o. Set ME-30(*)/U for 0.03 volt rms range and observe meter indication. p. Disconnect ME-30(*)/U and connect meter input to tray A2 INPUTS AUDIO IN test point. q. Set ME-30(*)/U for 0.1 volt rms range. r. Adjust AN/URM-127 tone output for indication of 40 mv rms on ME-30(*)/U meter. s. Connect AN/USM-281A to tray A2 OUTPUTS to MW test point. t. Observe AN/USM-281A trace while operating tray A2 SQUELCH switch from ON to OFF. u. Set tray A2 SQUELCH switch to ON. v. Observe AN/USM-281A trace while operating test set REC-XMIT switch from REC and XMIT. w. Observe AN/USM-281A trace while operating test set SERV SEL switch from SSB/NSK to CW. x. On test set, set REC-XMIT switch to REC, and SERV SEL switch to SSB/NSK. y. Set two-tone setup tone 2 for 2,500 Hz frequency and switch two-tone setup to tone 2 output. z. Adjust tone 2 output level for indication of 60 mv rms on ME-30(*)/U. aa. Switch two-tone setup to tone 1 output and adjust two-tone setup tone 1,500 Hz output level for indication of 40 mv rms on ME-30(*)/U. ab. Observe AN/USM-281A trace while operating tray A2 SQUELCH switch from OFF to ON. ac. Set two-tone setup output to tone 1+2. ad. Observe AN/USM-281A trace while operating tray A2 SQUELCH switch from ON to OFF. 	<p>Sine wave amplitude unchanged (module unsquelched).</p> <p>Waveform amplitude drops sharply (module squelched).</p> <p>Down 20 ±1 db from indication recorded in step <i>m</i> above.</p> <p>Waveforms amplitude relatively unchanged (module unsquelched; note waveform amplitude).</p> <p>Delayed decrease in waveform amplitude.</p> <p>Waveform amplitude returns to level observed in step <i>t</i> above.</p> <p>Waveform amplitude unchanged (module unsquelched).</p> <p>Waveform amplitude changes (module squelched).</p>
8	<p>Squelch Hang-Time:</p> <ul style="list-style-type: none"> a. Switch two-tone setup to tone 1 output. b. Adjust AN/USM-281A for dc triggering and external positive trigger slope. c. Observe AN/USM-281A trace while operating tray A2 SQUELCH SYNC switch from ON to OFF to determine time 	Loss of signal should occur in less than 5 seconds.

Table 4-8. Receiver Audio Module 1A10, Proof of Performance Tests—Continued

Step	Operation of test equipment	Performance standard
	difference between squelched and unsquelched conditions (tray A2 SQUELCH switch must be ON).	
d.	Disconnect all test equipment.	

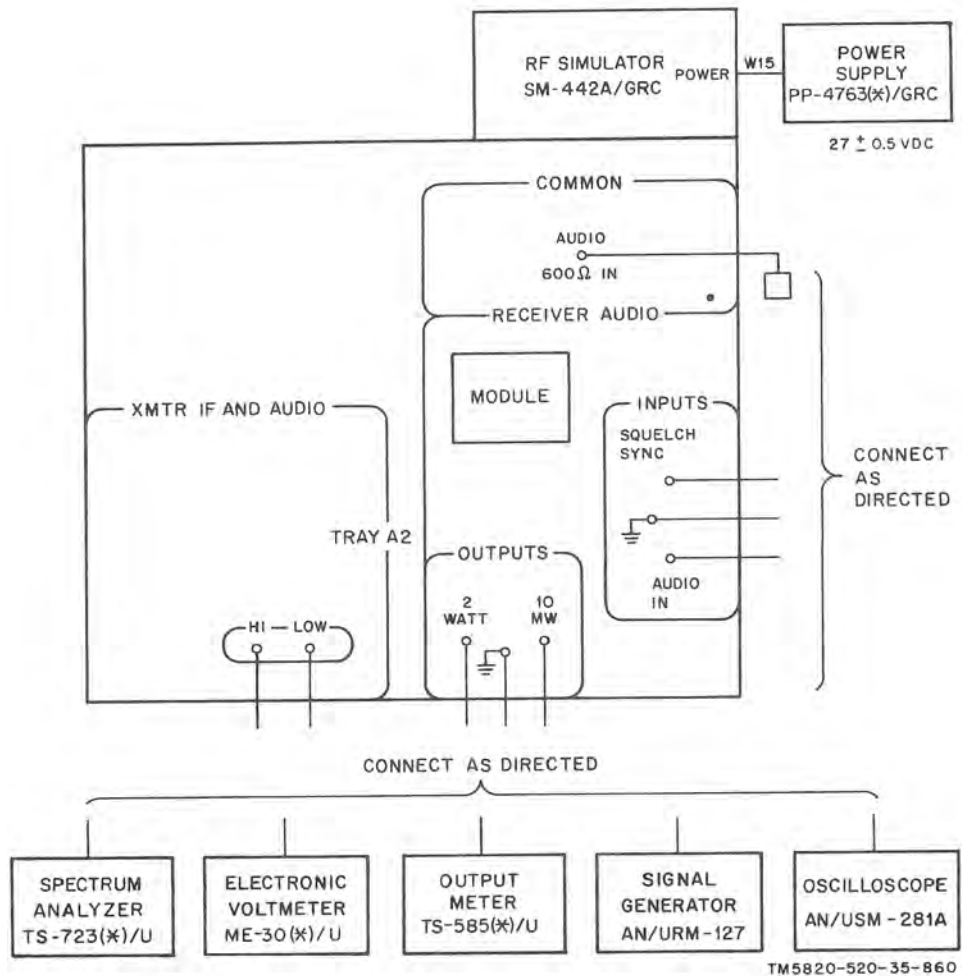

Figure 4-9. Receiver audio module 1A10, performance test setup.

Table 4-9. Dc-to-dc Converter and Regulator Module 1A11, Proof of Performance Tests

(Refer to figure 4-10.)

Step	Operation of test equipment	Performance standard
1	<p>Voltage Check:</p> <ol style="list-style-type: none"> Refer to TM 11-6625-847-12 for preliminary control settings of test set and tray A1. Set test set SERV SEL switch to STBY. Turn on all equipment and allow 15 minutes for warmup. <p style="text-align: center;">NOTE</p> <ol style="list-style-type: none"> For test points and test equipment connections, refer to figure 4-10. All tray A1 control panel designations used throughout these module tests refer to DC/DC CONVERTER section unless otherwise specified. 	

Table 4-9. Dc-to-Dc Converter and Regulator Module 1A11, Proof of Performance Tests—Continued

Step	Operation of test equipment	Performance standard
	d. Connect TS-352B/U to tray A1, HI and LOW jacks for measuring positive voltage and observe indication with TEST SELECTOR switch set to 1. (Adjust prime power if necessary.)	+27 ±2 vdc
	e. Set tray A1 TEST SELECTOR switch to 3 and observe TS-352B/U indication.	+125 ±10 vdc
	f. Disconnect TS-352B/U.	
	g. Set TEST SELECTOR switch to 4.	-33 ±2 vdc
	h. Connect TS-352B/U to tray A1, HI (ground) and LOW (-) jacks and observe TS-352B/U indication.	
2	Regulator Tests:	
	a. Disconnect TS-352B/U and connect it for measuring current, positive lead to HI jack, and negative lead to REG LOW jack within CONV-REC TEST area.	
	b. Depress REG pushbutton and record TS-352B/U indication.	Less than 140 ma
	c. Set LOAD SELECT switch to 100.	
	d. Connect shorting lead momentarily between LOAD SELECT test points; disconnect it.	
	e. Depress REG pushbutton and observe TS-352B/U indication.	Reading should be identical to step 2b above.
3	Converter Tests:	
	a. Disconnect TS-352B/U and connect it for measuring on 800 ma dc current at CON-REC TEST HI (positive) and CONV-LOW (negative) test points.	
	b. Depress CONV pushbutton and observe TS-352B/U indication.	Less than 800 ma.
	c. Connect shorting lead momentarily between LOAD SELECT test points; disconnect it.	
	d. Depress CONV pushbutton and record TS-352B/U indication.	Reading should be identical to step 3b above.
4	+125 Vdc Test:	
	a. Set tray A1 TEST SELECTOR switch to 3.	
	b. Connect AN/USM-281A to tray A1 HI and LOW jacks. (AN/USM-281A ground to LOW jack.)	
	c. Adjust AN/USM-281A controls to observe 10 kHz signal and to center trace on crt. Observe ripple amplitude at nominal 10 kHz on segment of +125 dc voltage.	Ripple less than 125 mv pp.
	d. Disconnect AN/USM-281A.	
5	-30 Vdc Test:	
	a. Set tray A1 TEST SELECTOR switch to 4.	
	b. Connect AN/USM-281A (ground to HI jack) and observe ripple amplitude at nominal 10 kHz on segment of -30 vdc voltage.	Ripple less than 100 mv pp.
6	6.3 Vac Test:	
	a. Set tray A1 TEST SELECTOR switch to 5.	
	b. Observe voltage amplitude at nominal 5 kHz PRF on segment of (6.3 vac) square wave filament voltage.	Square wave pp amplitude of 12 to 14 volts.
	c. Adjust AN/USM-281A so that trace of top of square wave can be easily viewed. Observe ripple (kink) on top of square wave.	Ripple less than 0.5 volt pp. (0, 4-3).
	d. Disconnect AN/USM-281.	
7	Regulated voltage ripple reduction test:	
	a. Set tray A1 TEST SELECTOR switch to 1.	
	b. Connect AN/USM-306 to tray A1 HI and LOW jacks.	
	c. Set tray A1 LOAD SELECT switch to 500.	
	d. Adjust AN/USM-306 for a peak at frequency of 120 Hz. Record dc indication.	
	e. Disconnect AN/USM-306 and connect it to LOAD SELECT test points.	
	f. Record AN/USM-306 db indication.	Indication to be down more than 45 db from step d above.
	g. Disconnect AN/USM-306.	
8	Voltage Regulator Tests:	
	a. Connect ME-26(*)/U to tray A1 HI (positive) and LOW jacks for measuring positive voltage with TEST SELECTOR switch set to 1.	+27 ±2 vdc
	b. Set tray A1 TEST SELECTOR switch to 2.	
	c. Obtain voltage readout from ME-26(*)/U.	+19.40 to +19.60 vdc
	d. Set tray A1 LOAD SELECT switch to 100.	

Table 4-9. Dc-to-Dc Converter and Regulator Module 1A11, Proof of Performance Tests—Continued

Step	Operation of test equipment	Performance standard
e.	Obtain voltage readout from ME-26(*)/U.	+19.10 to +19.90 vdc
f.	Set tray A1 TEST SELECTOR switch to 1.	
g.	Adjust prime dc voltage source for +22 volt dc indication on ME-26(*)/U.	
h.	On tray A1, set TEST SELECTOR switch to 2 and LOAD SELECT switch to 500.	
i.	Obtain voltage readout from ME-26(*)/U.	+19.30 to +19.70 vdc
j.	Set tray A1 TEST SELECTOR switch to 1.	
k.	Adjust prime dc voltage source for +30 volt dc indication on ME-26(*)/U.	
l.	Set tray A1 TEST SELECTOR switch to 2.	
m.	Obtain voltage readout from ME-26(*)/U.	+19.30 to +19.70 vdc
n.	Set tray A1 TEST SELECTOR switch to 1. Adjust prime power if necessary.	+27 to ±2 vdc
o.	On tray A1 set TEST SELECTOR switch to 2 and LOAD SELECT switch to 600.	
p.	Obtain voltage readout from ME-26(*)/U.	+19.10 to +19.90 vdc

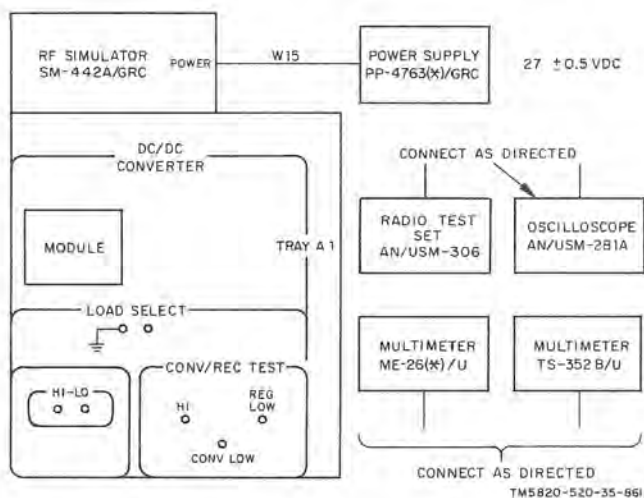

Figure 4-10. Dc-to-Dc converter and regulator module 1A11, performance test setup.

4-5. Module Test Procedures Peculiar to RT-834/GRC

The procedures for testing all modules that can be repaired at general support in the RT-834/GRC, except 10 and 1 kHz synthesizer module 1A4, and 100 Hz synthesizer module 1A1A2A8, are the same as those tests for RT-662/GRC modules in paragraph 4-4 of this chapter. The test procedures for module 1A4 (table 4-3) are the same with the exception of step 2, 7.1 Output Test. If the 1A4 module is from receiver transmitter, Radio RT-834/GRC follow the procedures of table 4-3 up to step 2, then use step 2 of table 4-10. When procedures of table 4-10 are completed, continue with step 3 of table 4-3. The test procedures for the 100 Hz synthesizer module 1A1A8 are found in table 4-11. The 1A1A2A8 module is tested while installed in a known good RT-834/GRC chassis. It is imperative that the RT-834/GRC used is equipped with 1A2, 1A3 and 1A4 modules which have passed their proof of performance tests.

Table 4-10. 10 and 1 kHz Synthesizer Module 1A4 (RT-834/GRC), Proof of Performance Tests

Step	Operation of test equipment	Performance standard
1	Refer to table 4-3 and perform the procedures described in step 1.	
NOTE		
The following tests are applicable for RT-834/GRC only. Refer to table 4-3 for test procedures for RT-662/GRC.		
2	7.089 Output Test:	
a.	Set test set POWER switch to OFF. Remove 10 and 1 kHz synthesizer module from tray A3.	
b.	Set test set POWER switch to ON. Connect AN/USM-281A to frequency dividers module 1A6, 1 kHz PULSE OUTPUT test point and observe pulse on AN/USM-281A.	Amplitude (p-p): 1.3 ± 0.3 volts. Width: 100 ± 20 μsec. PRF: 1 kHz (locked to 500 kHz freq std) (C, fig. 4-3).

Table 4-10. 10 and 1 kHz Synthesizer Module 1A4 (RT-834/GRC),
Proof of Performance Tests—Continued

Step	Operation of test equipment	Performance standard
	c. Set test set POWER switch to OFF, reinstall 10 and 1 kHz synthesizer module on tray A3; then set test POWER switch to ON.	
	d. Disconnect AN/USM-281A and connect it to tray A3 FREQ DIVIDER section 10 kHz SPECTRUM connector. On AN/USM-281A, connect vertical signal output to delayed trigger connector and adjust horizontal delay sweep and main sweep control to produce 10 kHz spectrum pulse display. Observe pulse on AN/USM-281A.	Amplitude (p-p): 110 ± 30 mv. Width: 7.5 ± 5 μsec. PRF: 10 kHz (D, fig. 4-3).
	e. Disconnect AN/USM-281A.	
	f. Connect AN/USM-306 (terminated in 50 ohms) to tray A3 FREQ. DIVIDER section 10 kHz SPECTRUM.	
	g. Adjust AN/USM-306 to 2.48 MHz and then to 2.57 MHz; observe indication for each frequency.	2.48 MHz; 2.6 ± 1.2 mv rms. 2.57 MHz; 2.6 ± 1.2 mv rms. -44 to -35.2 dbm.
	h. Turn test set 10 and 1 kHz OUTPUT AMPL switch OFF. Disconnect AN/USM-306 (terminated in 50 ohms) and connect it to tray A3, 7.1 MHz connector.	
	i. Adjust AN/USM-306 to 7.089 MHz and observe indication. Adjust 7.089 MHz level control.	35 ± 5 mv rms. -17.5 to -15 dbm.
	j. Set tray A3 FREQ SELECT section 10 kHz control to each of its positions: observe AN/USM-306 indication at each position (0-9). Use wideband on AN/USM-306.	All positions: 35 ± 5 mv rms.
	k. Set tray A3 FREQ SELECT section 1 kHz control to each position and observe AN/USM-306 indication at each position (0-9).	All positions: 35 ± 5 mv rms.
	l. Adjust AN/USM-306 to 9.07 MHz and observe indication.	1 mv rms maximum.
	m. Repeat steps j and k above.	All positions 10 kHz and 1 kHz FREQ SELECT controls: 1 mv rms maximum.
	n. Adjust AN/USM-306 to 7.089 MHz and observe any spurious responses within ± 100 kHz of 7.089 MHz.	Spurious responses to be minimum of 50 db down from level measured in step j above.
	o. Disconnect AN/USM-306.	
	p. Connect AN/USM-207 to tray A3 7.089 MHz connector and observe AN/USM-207 indication.	7.089 MHz ± 400 Hz.
	q. Disconnect AN/USM-207.	
3	10 and 1 kHz Output Test: Proceed to step 3 of table 4-3.	

Table 4-11. 100 Hz Synthesizer Module 1A1A2A8, Proof of Performance Test

Step	Operation of test equipment	Performance standard
1	Preliminary Setup:	
	a. Insure that the RT-834/GRC chassis contains known good 100 kHz 1A2, frequency standard module 1A3, 10 and 1 kHz synthesizer module 1A4, and frequency dividers module 1A6.	
	b. Connect PP-4763(*)/GRC to the POWER connector on the front panel. Turn on power supply and set for 27 volts output.	
	c. Turn on AN/USM-207. Turn RT-834/GRC SERVICE SELECTOR switch to AM. Allow equipment to warmup for 15 minutes.	
2	Measurements:	
	a. Set RT-834/GRC frequency controls for 02.600X MHz (X = any digit from 0 to 9).	
	b. Using the AN/USM-207, measure and record the frequency at the 7.089 MHz test point on top of 10 and 1 kHz synthesizer module.	7.089 MHz ± 400 Hz
	c. Subtract algebraically 7.089000 MHz from the frequency recorded in step b. The difference will be the frequency error, either positive or negative in the 7.089 MHz output.	
	d. Using the AN/USM-207, measure and record the frequencies at the 100 kHz SYNTH OUPT test point on top of the 100 kHz	

Table 4-11. 100 Hz Synthesizer Module 1A1A2A8, Proof of Performance Tests—Continued

Step	Operation of test equipment	Performance standard
	synthesizer module for each setting (0 through 9) of the 100 Hz control on the front panel of RT-834/GRC.	
e.	Subtract algebraically the 7.089 MHz error (determined in step c) from the frequency measured in step d.	The last three digits must equal the setting of 100 Hz control ± 3 Hz.

Example:

- Positive error in 7.089 MHz (step c) with 100 Hz control set to 5.

Measured in step b	=	7.089,218 MHz	
Subtraction (step c):		7.089,218	
		-7.089,000	
<hr/>			
10 and 1 kHz error		218 Hz	
Measured 100 kHz (step d)	=	23.000,718 MHz	
Subtract error (step c)	-	218	
<hr/>			
Must correspond to "5" setting		23.000,500 MHz	500 ± 3 Hz

- Negative error in 7.089 MHz (step c) with 100 Hz control set to 2.

Measured in step b	=	7.088,934 MHz	
Subtraction (step c):		7.088,934	
		-7.089,000	
<hr/>			
10 and 1 kHz error		-066 Hz	
Measured 100 kHz (step d)	=	23.000,134	200 ± 3 Hz
Subtract error (step e)	(-)	-066	
<hr/>			
Must correspond to "2" setting		23.000,200	

The examples above are provided to show the necessary mathematical operations. Actual measurements will vary from module to module as will frequency error.

4-6. AM-3349/GRC-106 Assembly Tests

Refer to paragraphs 4-1 through 4-3 for preliminary procedures. General support tests for

the AM-3349/GRC-106 are contained in tables 4-12 through 4-18 and are to be used in addition to tests at lower levels of maintenance.

Table 4-12. Antenna Coupler Assembly 2A3, Proof of Performance Tests

(Refer to figure 4-11.)

Step	Operation of test equipment	Performance standard
1	Connect antenna coupler 2A3 to ANTENNA COUPLER section of tray A5.	
2	Refer to TM 11-6625-847-12 for preliminary control settings of test set and tray A5.	
NOTE		
All tray A5 control panel designations used throughout these tests refer to ANTENNA COUPLER section unless otherwise specified.		
3	Set tray A5 COUPLER TERMINATION switch to 50Ω DUMMY LOAD.	
4	Refer to table 4-13 and set tray A5 CODE and COUPLER TERMINATION switches to each combination specified and check for current tuning indications.	In accordance with table 4-13.
5	On tray A5, set CODE switch to 4 and COUPLER TERMINATION switch to 50Ω DUMMY LOAD. Observe that antenna coupler assembly components 2A3C27, 2A3S1, 2A3S2, and 2A3S3 are in position indicated in figure 4-11.	
6	Disconnect all test equipment.	

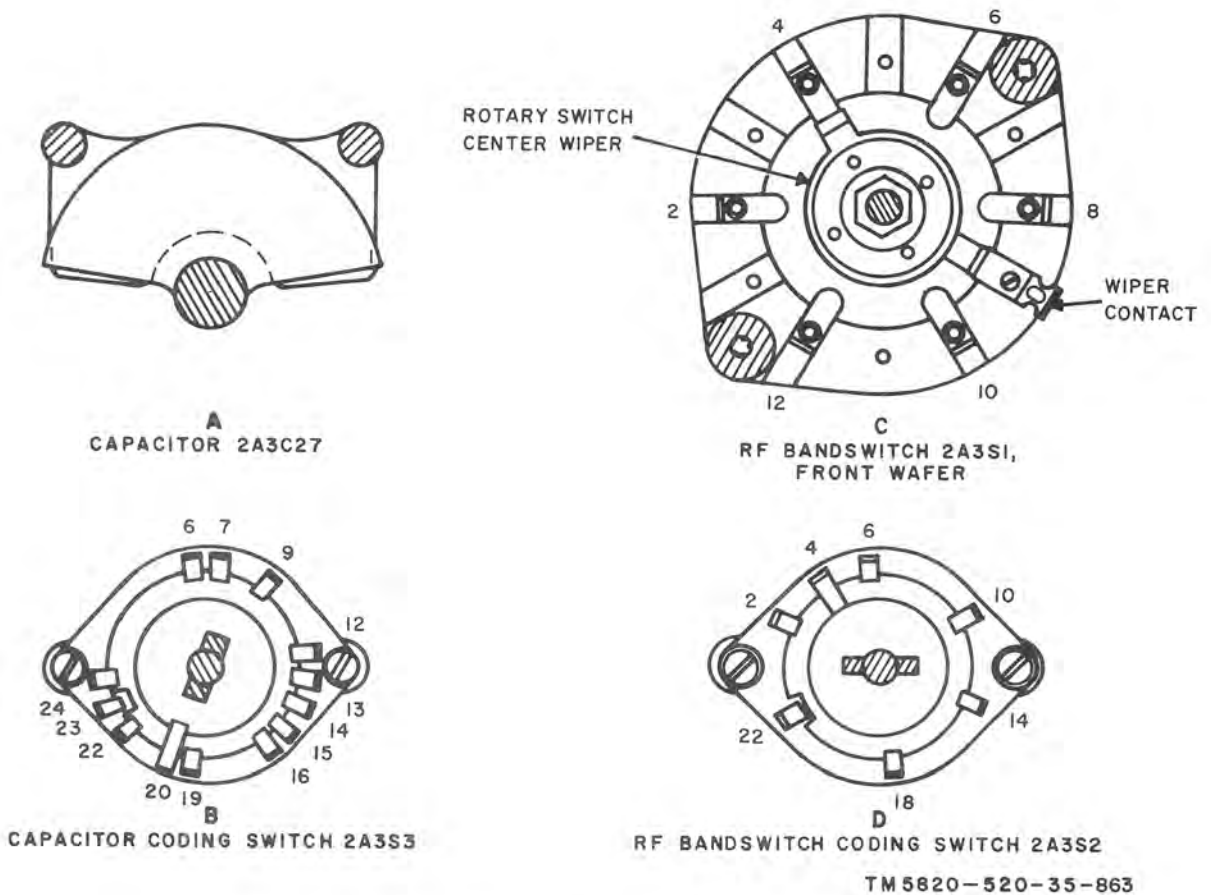

Figure 4-11. Antenna coupler assembly 2A3, control positioning.

Table 4-13. Antenna Coupler Coding Proof of Performance Tests

Code switch	COUPLER TERMINATION switch	FREQUENCY MHz	LAMP*	Code switch	COUPLER TERMINATION switch	FREQUENCY MHz	LAMP*
1-3	50 Ω DUMMY LOAD	-----	A	8	50Ω DOUBLET	12 to 14	C
4		2 to 5	D	9		14 to 15	C
5		5 to 7	C	10		15 to 22	C
6		7 to 12	C	11		22 to 27	B
7		12 to 14	C	12		27 to 30	B and C
8		14 to 19	C	6		10 to 11	A and C
9		19 to 24	C	1-3		-----	A
10		24 to 30	D	4		2 to 5	D
4		2 to 5	C	5		5 to 7	C
1		WHIP	2 to 2.5	A		6	7 to 12
2	2.5 to 3		B	7	12 to 14	C	
3	3 to 3.5		B	8	14 to 19	C	
4	3.5 to 4		B	9	19 to 24	C	
5	4 to 10		B	10	24 to 30	D	
6	10 to 11		D	4	2 to 5	C	
7	11 to 12		C				

* - Indicated lamp will light while antenna coupler is tuning.
 A - BAND SW MOTOR may or may not light (bandswitch may or may not tune to new position).
 C - CAP. MOTOR will light (capacitor motor will be required to tune to new position).
 D - Lamps undefined for this point in sequence.

Table 4-14. Discriminator Assembly 2A4, Proof of Performance Tests

(Refer to figure 4-12.)

Step	Operation of test equipment	Control settings and operation of equipment	Performance standard
1	Preliminary Procedures:		
	a. Remove AM-3349/GRC-106 chassis from case. Remove antenna coupler assembly 2A3, and disconnect discriminator assembly 2A4.		
	b. For test points and test equipment connections, refer to figure 4-12.		
	NOTE		
	All tray A5 control panel designations used throughout these tests refer to DISCRIMINATOR section unless otherwise specified.		
	c. Refer to TM 11-6625-847-12 for preliminary control settings of test set and tray A5.		
	d. Set test set SERV SEL switch to SSB/NSK, 1 MHz FREQ selector switch to 2 (2 MHz) and REC-XMIT switch to REC.		
	e. Set tray A5 TEST SELECTOR switch to 3.		
	f. -----	Set AM-3349/GRC-106 HV RESET switch to OPERATE.	
	g. Turn on all equipment, except AM-3349/GRC-106, and allow 15 minutes for warmup.		
2	Power Out Tests:		
	a. -----	Direct a blower or fan toward high voltage section at rear of AM-3349/GRC-106 front panel assembly.	
	b. Adjust AN/GRM-50 for 2.000 MHz output frequency as indicated by AN/USM-207.		
	c. -----	On AM-3349/GRC-106, set PRIM. PWR. switch to ON and HV RESET switch to TUNE.	
	NOTE		
	Allow 60 seconds for a high voltage indication on front panel TEST METER.		
	d. Adjust AN/GRM-50 for 53 mv rms output level as indicated by ME-30(*)/U.		
	e. Connect AN/USM-281A to tray A5, HI and LO test points to measure dc	-----	+53 ±7 mv dc

Table 4-14. Discriminator Assembly 2A4, Proof of Performance Tests—Continued

Step	Operation of test equipment	Control settings and operation of equipment	Performance standard
	level and observe indication.		
f.	Disconnect AN/USM-281A and connect it to tray A5 ALC OUT connector for measuring dc level. Observe indication.		+5 ±1 vdc
g.	Disconnect AN/USM-281A and AN/GRM-50.		
h.		Set AM-3349/GRC-106 HV RESET switch to OPERATE.	
i.	Set test set 1 MHz FREQ selector switch to 5.		
j.	Adjust AN/GRM-50 for 5.000 MHz output frequency as indicated by AN/USM-207 and connect to RF DRIVE input on AM-3349/GRC-106.		
k.		Set AM-3349/GRC-106 HV RESET switch to TUNE.	
l.	Repeat steps d through h above.		
m.	Set test frequency selectors as follows: .1 MHz to 5, 1 MHz to 9, and 10 MHz to 2.		
n.	Adjust AN/GRM-50 for output frequency of 29.500 MHz as indicated by AN/USM-207, and connect to rf drive input connector.		
o.		Set AM-3349/GRC-106 HV RESET switch to TUNE	
p.	Repeat steps d through g above.		
3	Average Level Control Tests:		
a.	Set test set frequency selectors as follows: .1 MHz to 0, 1 MHz to 5, and 10 MHz to 0.		
b.	Adjust AN/GRM-50 for 5.000 MHz output frequency as indicated by AN/USM-207 and for 1,000 Hz internal modulation of rf output at 100% modulation level.		
c.		Set AM-3349/GRC-106 HV RESET switch to TUNE.	
d.	Using AN/USM-281A, connect Channel A to tray A5, RF IN connector, and Channel B to tray A5, ALC OUT connector.		
e.	Adjust AN/GRM-50 level so that no clipping		

Table 4-14. Discriminator Assembly 2A4, Proof of Performance Tests—Continued

Step	Operation of test equipment	Control settings and operation of equipment	Performance standard
	appears on observed waveform of step below. (ME-30(*)/U indication should be 100 to 200 v rms.)		
f.	Observe waveform on Channel B (ALC OUT).		T, figure 4-3
g.	Observe that trace B follows rf envelope displayed on trace A.		U, figure 4-3
h.	Disconnect all test equipment.		

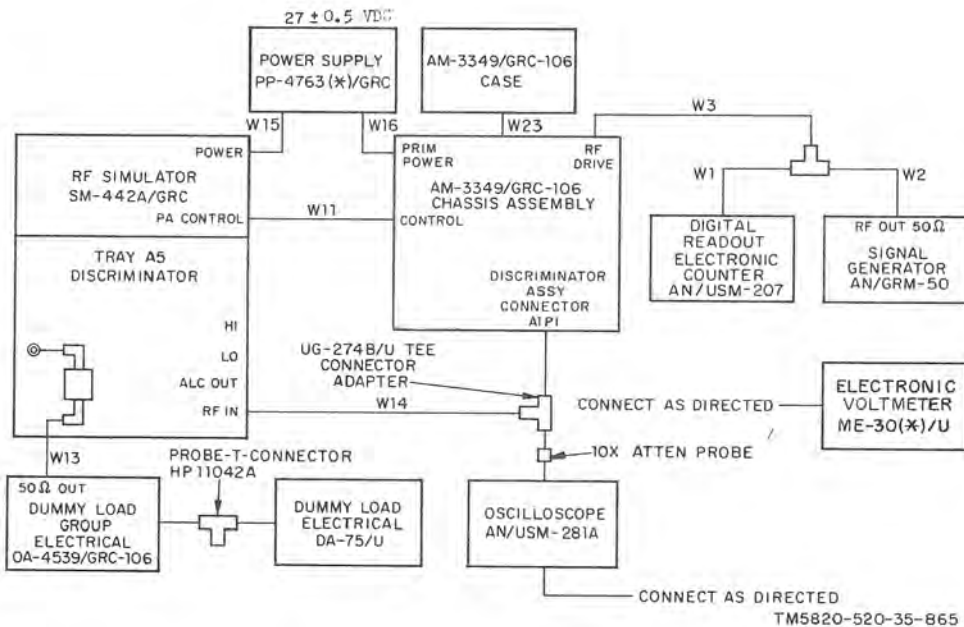

Figure 4-12. Discriminator assembly 2A4, performance test setup.

Table 4-15. Front Panel Assembly 2A5, Proof of Performance Tests

Step	Operation of test equipment	Control settings and operation of equipment	Performance standard
1	-----	Remove front panel from AM-3349/GRC-106.	
2	Connect equipment as shown in figure 4-13.		
3	For preliminary control settings on the test set and tray A4, refer to TM 11-6625-847-12.		
4	-----	AM-3349/GRC-106 preliminary settings: a. PRIM. PWR. switch to OFF. b. HV RESET switch to OPERATE. c. TEST METER switch to DRIVER CUR.	
5	Test Set Settings: a. REC-XMIT switch to XMIT.		

Table 4-15. Front Panel Assembly 2A5, Proof of Performance Tests—Continued

Step	Operation of test equipment	Control settings and operation of equipment	Performance standard
b.	SERV SEL switch to SSB/NSK.		
c.	All MHz. FREQ. switches to 0.		
NOTE			
All tray A4 control panel designations used throughout these front panel assembly tests refer to the PA METER TEST section unless otherwise specified.			
6	Apply power to test equipment.		
7	Meter tests:		
a.	Connect AN/USM-281A to tray A4, ALC METER test points and observe indication.	-----0 vdc.	
b.	Adjust tray A4, ALC METER control to obtain center scale indication on AM-3349/GRC-106 TEST METER. Observe AN/USM-281 deflection.	-----+108 ±21 mv dc.	
c.	Set tray A4, ALC METER control fully counterclockwise.		
d.	-----Set AM-3349/GRC-106 TEST METER switch to POWER OUT.		
e.	Adjust tray A4, ALC METER control to obtain center scale indication on AM-3349/GRC-106 TEST METER. Observe AN/USM-281A deflection.	-----108 ±21 mv dc.	
f.	Set tray A4, ALC METER control fully counterclockwise.		
g.	Disconnect AN/USM-281A and connect it to tray A4 grid drive test points.		
h.	-----Set AM-3349/GRC-106 TEST METER switch to GRID DRIVE.		
i.	Adjust tray A4 GRID DRIVE control to obtain center scale indication on AM-3349/GRC-106 TEST METER. Observe AN/USM-281A deflection.	-----15 ±3 vdc.	
j.	Set tray A4 GRID DRIVE control fully counterclockwise.		
k.	Disconnect AN/USM-281A		
l.	Connect AN/USM-281A to tray A4 antenna load/tune test points.		

Table 4-15. Front Panel Assembly 2A5, Proof of Performance Tests—Continued

Step	Operation of test equipment	Control settings and operation of equipment	Performance standard
m.	-----	Set AM-3349/GRC-106 HV RESET switch to TUNE.	
n.	Set ANT LOAD-ANT TUNE switch to ANT TUNE. Adjust tray A4 ANTENNA LOAD-TUNE control so that AM-3349/GRC-106 ANT TUNE meter indicator is at extreme right end of red bar to the right. Observe AN/USM-281A deflection.	-----	108 ±21 mv dc.
o.	Adjust tray A4 ANTENNA LOAD-TUNE control so that AM-3349/GRC-106 ANT TUNE meter indicator is at extreme left end of red bar to the left. Observe AN/USM-281A indication.	-----	108 ±21 mv dc.
p.	-----	Set AM-3349/GRC-106 HV RESET switch to OPERATE.	+1.5 ±0.3 vdc, or +0.68 ±0.14 vdc for Order No. 05144-PP-64.
q.	Adjust tray A4 ANTENNA LOAD-TUNE control so that AM-3349/GRC-106 ANT TUNE meter indicator is at start of red bar to the right. Observe AN/USM-281A deflection.	-----	-1.5 ±0.3 vdc, or -0.68 ±0.14 vdc for Order No. 05144-PP-64.
r.	Adjust tray A4 ANTENNA LOAD-TUNE control so that AM-3349/GRC-106 ANT TUNE meter indicator is at start of red bar to the left. Observe AN/USM-281A deflection.	-----	
s.	Adjust tray A4 ANTENNA LOAD-TUNE control so that AM-3349/GRC-106 ANT TUNE meter indicator is at center scale.	-----	
t.	Set tray A4 ANT LOAD-ANT TUNE switch to ANT LOAD.	-----	
u.	-----	Set AM-3349/GRC-106 HV RESET switch to TUNE.	
v.	Adjust tray A4, ANTENNA LOAD-TUNE control so that AM-3349/GRC-106 ANT LOAD meter indicator is at extreme right end of red bar to the right. Observe AN/USM-281A deflection.	-----	+108 ±21 mv dc.
w.	Adjust tray A4, ANTENNA LOAD-TUNE control so that AM-3349/GRC-106 ANT LOAD meter indicator is at extreme left	-----	-108 ±21 mv dc.

Table 4-15. Front Panel Assembly 2A5, Proof of Performance Tests—Continued

Step	Operation of test equipment	Control settings and operation of equipment	Performance standard
	end of red bar to the left. Observe AN/USM-281A deflection.		
x.	-----	Set AM-3349/GRC-106 HV RESET switch to OPERATE.	
y.	Adjust tray A4 ANTENNA LOAD-TUNE control so that AM-3349/GRC-106 ANT LOAD meter indicator is at start of red bar to the right. Observe AN/USM-281A deflection.	-----	+482 ±96 mv dc, or +86 ±18 mv dc for Order No. 05144-PP-64.
z.	Adjust tray A4, ANTENNA LOAD-TUNE control so that AM-3349/GRC-106 ANT LOAD meter indicator is at start of red bar to the left. Observe AN/USM-281A deflection.	-----	-482 ±96 mv dc, or -86 ±18 mv dc for Order No. 05144-PP-64.
aa.	Disconnect AN/USM-281A.		
ab.	Adjust tray A4 ANTENNA LOAD-TUNE control so that AM-3349/GRC-106 ANT LOAD meter indicator is at center scale.		
8	Continuity Tests:		
	CAUTION		
	Controls must be operated in the sequence given to prevent equipment damage.		
a.	Confirm operation of all tray A4 indicator lamps pressing each one to test for lighting.		
b.	-----	Check to see that AM-3349/GRC-106 HV RESET switch is at OPERATE.	
c.	Set test set REC-XMIT switch to REC.		
d.	Set tray A4, RF BAND-50Ω WHIP switch to 50Ω and observe lighted lamps.	-----	Lamps B1, B3, C3, and C5 will light.
e.	Set test set REC-XMIT switch to XMIT. Observe lighted lamps.	-----	Lamps B1, B2, C3 and C5 will light.
f.	-----	Set AM-3349/GRC-106 HV RESET switch to TUNE. Observe lighted lamps.	Lamps B1, B3, B5, C3, and C4 will light.
g.	-----	Push AM-3349/GRC-106 50 OHM LINE flag counterclockwise and hold.	Lamps B2, B3, B5, C3, and C5 will light.
h.	-----	Set AM-3349/GRC-106 HV RESET switch to OPERATE.	Lamps B2, B3, B5, C3, and C5 will light.
i.	-----	Release AM-3349/GRC-106 50 OHM LINE flag.	
j.	-----	Set AM-3349/GRC-106 HV RESET switch to TUNE.	

Table 4-15. Front Panel Assembly 2A5, Proof of Performance Tests—Continued

Step	Operation of test equipment	Control settings and operation of equipment	Performance standard
k.	Set test set REC-XMIT switch to REC.	NOTE Disregard pairs of half lighted lamps during the continuity test.	
l.	Rotate test set 1 MHz FREQ switch from 0 to 9, while observing lamp B4.	-----	Lamp lights between switch settings.
m.	Set test set 1 MHz FREQ switch to 0. Observe that lamps A1 through A5 are not lighted.		
n.	Check the 5-line code by observing lamps A1 through A5 for the various positions of the test set MHz FREQ switches. Switch positions and the corresponding lamp sequences are given in table 4-16. (Disregard all lamps other than A1 through A5 when performing these tests.)	-----	See table 4-16.
9	Continuity Checks:		
a.	-----	Check to see that AM-3349/GRC-106 PRIM PWR switch is at OFF.	
b.	-----	Set AM-3349/GRC-106 TEST METER switch to PRIM VOLT.	
c.	On test set, check to see that the 500 V LOAD is at low, 2400 VOLT LOAD switch is at 1, and REC-XMIT switch is at REC.		
d.	Connect between 2A5A2T1-3 and ground. See figure 2-33 for location.		
e.	Turn on blower and direct output to the 2A5A2Q2 heat sink.		
f.	-----	Connect 27 vdc power source to PRIM. POWER connector on AM-3349/GRC-106 front panel.	
g.	Turn on 27 vdc power source and adjust for 27 vdc.		
h.	-----	Set the AM-3349/GRC-106 PRIM. PWR. switch to ON, and the HV RESET switch to TUNE. Reset by switching to OPERATE and then back to TUNE if necessary.	
i.	Observe ammeter indication on 27 vdc power source.	-----	Approximately 12 amp. Observe that lamp C2 on tray A4 is lighted.
j.	Connect TS-352B/U between PRIM V test point on the AM-3349/GRC-106 and ground. See figure 2-31 for location of test point.	-----	+27 ±1 vdc.
k.	-----	Observe AM-3349/GRC-106 TEST METER indication.	Pointer should indicate in the dark green (Δ) portion of scale.

Table 4-15. Front Panel Assembly 2A5, Proof of Performance Tests—Continued

Step	Operation of test equipment	Control settings and operation of equipment	Performance standard
l.	-----	Set AM-3349/GRC-106 TEST METER switch to LOW VOLT.	
m.	-----	Observe AM-3349/GRC-106 TEST METER indication.	Pointer should indicate in dark green (Δ) portion of scale.
n.	Connect TS-352B/U between LV test point on the AM-3349/GRC-106 and ground. See figure 2-31 for location of test point.	-----	+525 \pm 25 vdc.
o.	Set test set 500 V LOAD switch to HIGH. Observe TS-352B/U indication.	-----	+525 \pm 25 vdc.
p.	Set test set 500 V LOAD switch to LOW.		
q.	-----	Set AM-3349/GRC-106 TEST METER switch to HIGH VOLT.	
r.	-----	Observe AM-3349/GRC-106 TEST METER indication.	Pointer should indicate in dark green portion of upper scale.
s.	Connect TS-352B/U between HV test point on the AM-3349/GRC-106 and ground. See figure 2-31 for location of test point.	-----	+22.8 to +25.2 vdc.
t.	-----	Set AM-3349/GRC-106 HV RESET switch to OPERATE.	
u.	Depress lamp C1 on tray A4 to disable high voltage circuitry.	-----	TS-352B/U indicates 0 volt. AN/USM-281A waveform disappears.
v.	Set the test set REC-XMIT switch to XMIT, then back to REC and observe TS-352B/U and AN/USM-281A indications.	-----	TS-352B/U: +22.8 to +25.2 vdc. AN/USM-281A: Period: 88 \pm 22 ms. Rise time: \leq 30 μ sec. Fall time: \leq 30 μ sec.
w.	Rotate test set 2400 VDC LOAD switch from positions 1 through 8.	-----	At position 7, the AN/USM-281A waveform will disappear.
x.	Set test set 2400 VDC LOAD switch to position 1.		
y.	-----	Reset high voltage on AM-3349/GRC-106 by setting the HV RESET switch to OPERATE.	AN/USM-281A waveform should reappear.
z.	-----	Set AM-3349/GRC-106 TEST METER switch to PA CUR.	
aa.	-----	Press and hold AM-3349/GRC-106 PA IDLE CUR switch (S1), and observe TEST METER indication.	TEST METER will show full-scale deflection to the right.
ab.	-----	Release AM-3349/GRC-106 PA IDLE CUR switch.	
ac.	Connect TS-352B/U between 2A5A3E1 and ground.	-----	10 to 12 vdc.
ad.	Turn off power source to AM-3349/GRC-106 front panel. Leave test set power on and set test set REC-XMIT switch to XMIT.		
ae.	Connect TS-352B/U between the normally open contact of 2A5K1 (rear con-	-----	Less than 1 ohm.

Table 4-15. Front Panel Assembly 2A5, Proof of Performance Tests—Continued

Step	Operation of test equipment	Control settings and operation of equipment	Performance standard
	tact) and the WHIP connector on AM-3349/GRC-106. See figure 2-33 for location of relay.		
af.	Connect TS-352B/U between the normally open contact of 2A5K1 (rear contact) and the 50 OHM LINE connector (hold back flag switch) on AM-3349/GRC-106.	-----	Less than 1 ohm.
ag.	Release flag switch. Connect TS-352B/U between AM-3349/GRC-106 RCVR ANT and WHIP connectors.	-----	Greater than 1 megohm.
ah.	Connect TS-352B/U between AM-3349/GRC-106 front panel ground and the following connectors: RF DRIVE RCVR ANT 50 OHM LINE WHIP	-----	Greater than 1 megohm.
ai.	Set test set REC-XMIT to REC.		
aj.	Connect TS-352B/U between AM-3349/GRC-106 RCVR ANT and WHIP connectors.		
ak.	-----	Set AM-3349/GRC-106 PRIM. PWR. switch to OFF.	
al.	Turn off power source to AM-3349/GRC-106 (if separate).		
am.	Turn blower off.		
an.	Set test set SERV SEL and PRIM POWER switches to OFF.		
ao.	Set tray A4 POWER switch to OFF.		
ap.	Disconnect all test equipment and cables from the AM-3349/GRC-106 front panel.		
NOTE			
Refer to figures 2-31 and 2-33 for the location of test points called out in the following steps.			
aq.	Connect TS-352B/U between AM-3349/GRC-106 test point J1-A1 and RF DRIVE connector.	-----	Less than 1 ohm.
ar.	Connect TS-352B/U between AM-3349/GRC-106 test point J1-26 and the front panel casing.	-----	Less than 1 ohm.

Table 4-15. Front Panel Assembly 2A5, Proof of Performance Tests—Continued

Step	Operation of test equipment	Control settings and operation of equipment	Performance standard
as.	Connect TS-352B/U between AM-3349/GRC-106 50 OHM LINE and RCVR ANT connectors.	-----	Less than 1 ohm.
at.	Connect positive end of TS-352B/U to AM-3349/GRC-106 test point A2K1-4 and the negative end to test point A2K1-2.	-----	Greater than 100K ohms.
au.	Reverse TS-352B/U leads, connecting positive end to A2K1-2 and negative end to A2K1-4.	-----	Less than 200 ohms.
av.	Disconnect all test cables.		

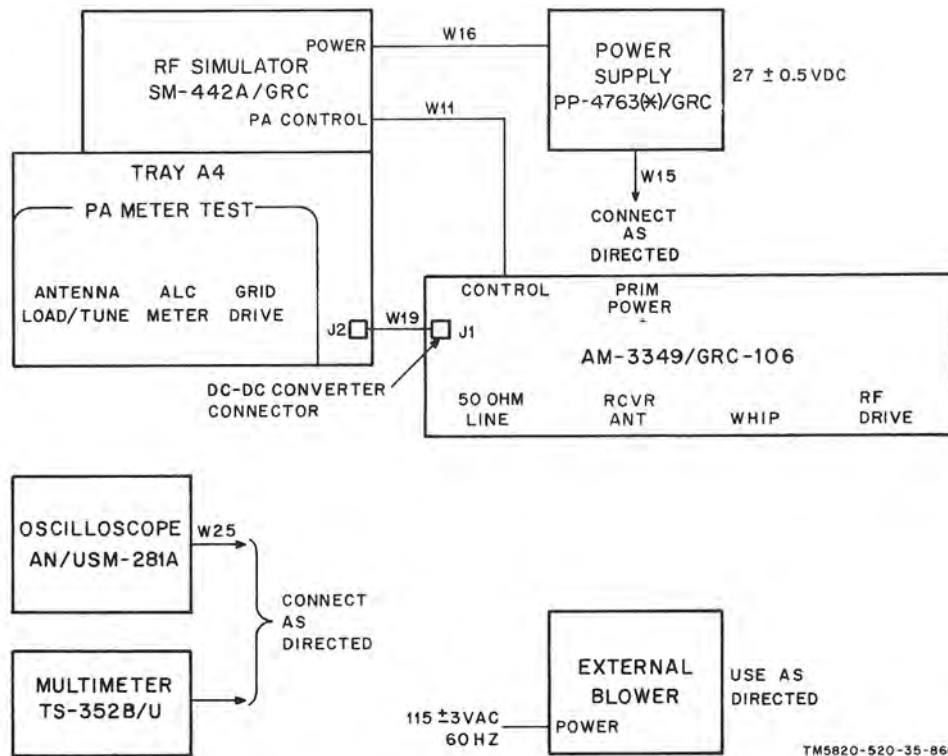

Figure 4-13. AM-3349/GRC-106 Front panel assembly 2A5, performance test setup.

Table 4-16. Switch Position and Lamp Sequence, Code Line Check

MHz FREQ switch positions			Equivalent freq. (in MHz)	Illuminated lamps				
.1 MHz	1 MHz	10 MHz		A1	A2	A3	A4	A5
0	2	0	2.0	--	X	--	X	--
5	2	0	2.5	--	X	--	--	--
0	3	0	3.0	--	--	X	--	X
5	3	0	3.5	--	--	X	--	--
0	4	0	4.0	X	--	X	X	--
0	5	0	5.0	--	X	--	X	X
0	6	0	6.0	X	X	X	--	X
0	7	0	7.0	--	X	X	X	--
0	8	0	8.0	X	--	X	--	X

Table 4-17. Dc-to-Dc Inverter Assembly 2A6A1, Proof of Performance Tests—Continued

Step	Operation of test equipment	Performance standard
	b. Set tray A4 TEST SELECTOR to 2.	
	c. Connect AN/USM-281A Channel A and B probes to tray A4 TEST SELECTOR HI and LO jacks, respectively. Invert one channel and measure amplitude of square wave on AN/USM-281A.	256 ± 14 v pp: (Q, 4-3)
	d. Set tray A4 EXTERNAL BLOWER switch to LO and measure amplitude of square wave on oscilloscope.	120 ± 20 v pp: (R, fig. 4-3).
	e. Set tray A4 TEST SELECTOR switch to 3 and measure amplitude of square wave on AN/USM-281A.	12.6 ± 1 v pp.
	f. Set AN/USM-281A for "added algebraically" mode.	
	g. Set tray A4 TEST SELECTOR to 4 and measure dc voltage deflection with TS-325B/U.	100 to 125 vdc.
	h. Set tray A4 TEST SELECTOR to 5 and adjust AN/USM-281A for measuring square wave amplitude.	256 ± 14 v pp.
4	High, Low Load Frequency Test:	
	a. Adjust AN/USM-207 for measuring 400 Hz inverter frequency and connect to vertical signal output of AN/USM-281A. Observe frequency indication.	+25 400 Hz -10
	b. Set tray A4 EXTERNAL BLOWER switch to HI and observe AN/USM-207 indication.	+25 400 Hz -10
	c. Disconnect AN/USM-207 and AN/USM-281A.	
5	Oscillator Start Under Load:	
	a. Set tray A4 TEST SELECTOR switch to 1.	
	b. Connect TS-352B/U to tray A4 TEST SELECTOR HI (+) and LO jacks for measuring positive voltage.	
	c. Adjust prime dc voltage source for 20.9 vdc indication on TS-352B/U.	
	d. Disconnect TS-352B/U.	
	e. Set tray A4 TEST SELECTOR switch to 3.	
	f. Connect AN/USM-281A using procedure given in step 3c to tray A4 TEST SELECTOR HI and LO jacks. Observe waveform.	Waveform present.
	g. Observe AN/USM-281A while depressing tray A4 INPUT CURRENT pushbutton.	AN/USM-281A waveform disappears.
	h. Release tray A4 INPUT CURRENT pushbutton while observing AN/USM-281A.	AN/USM-281A waveform reappears.
	i. Disconnect all test equipment.	

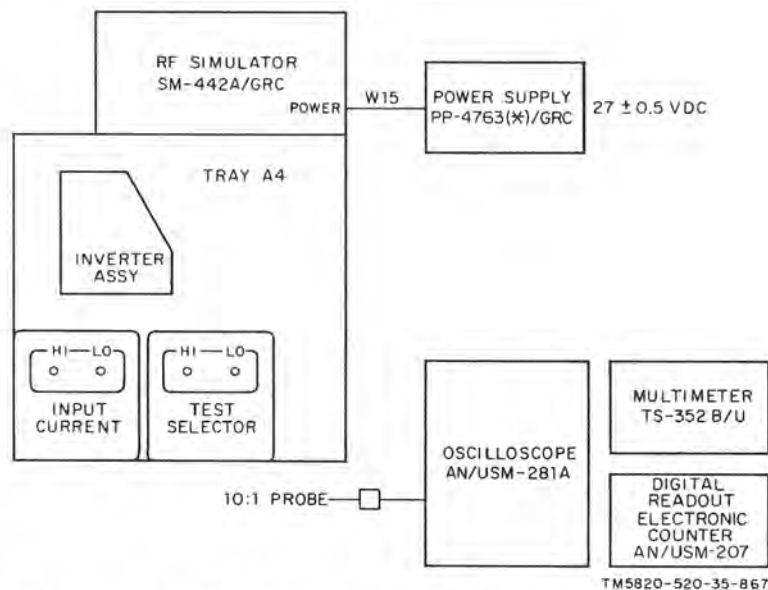

Figure 4-14. Dc-to-ac inverter assembly 2A6A1, performance test setup.

Table 4-18. Relay Control Assembly 2A7, Proof of Performance Tests

(Refer to figure 4-15.)

Step Operation of test equipment Performance standard

NOTE

1. For test points and test equipment connections, refer to figure 4-15.
2. All tray A5 control panel designations used throughout these tests refer to RELAY section unless otherwise specified.

1 Relay Operation Tests:

- a. Refer to TM 11-6625-847-12 for preliminary control settings on test set and tray A5.
- b. Set test set SERV SEL switch to STBY.
- c. Turn on all equipment.
- d. Use table below to check for proper operation of relays.
Use Press to Test function of indicator lamps to check that each lamp is operational. Set test set SERV SEL switch to SSB/NSK.

RELAY CONTROL switch position	Indicator lamp No.	Indication						
		1	2	3	4	5	6	7
1		on	(*)	(*)	off	off	off	(**)
2		on	on	off	on	off	off	on
3		on	on	off	off	on	off	on
4		on	on	off	off	off	on	on
5		on	on	off	off	off	on	on

* Lamp lights after approximately 75 seconds delay.
 **Lamp starts at on and goes out after approximately 75 seconds delay.

- e. Set tray A5 RELAY CONTROL switch to 1.
- f. Operate tray A5 end panel POWER switch to OFF and then to ON. 68 to 90 sec.
Note time interval from moment power is reapplied until moment indicator lamp 2 lights.
- g. Set tray A5 POWER switch to OFF and remove 2A7 assembly.

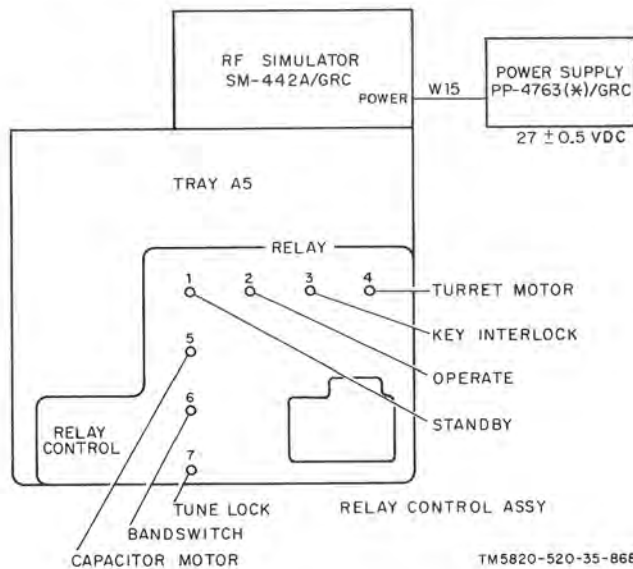

Figure 4-15. Relay control assembly 2A7, performance test setup.

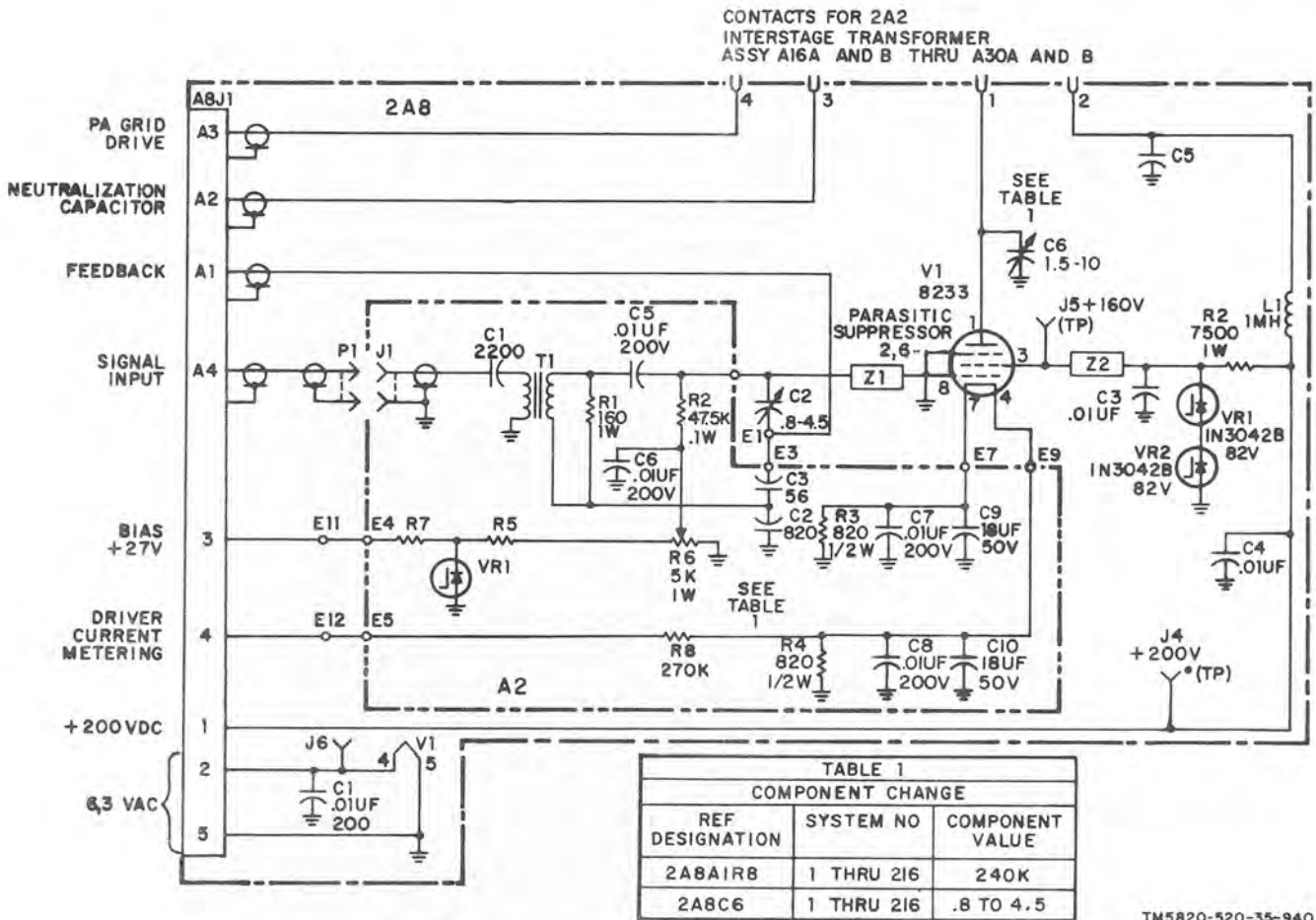

Figure 4-16. AM-3349/GRC-106, driver assembly 2A8, schematic diagram.

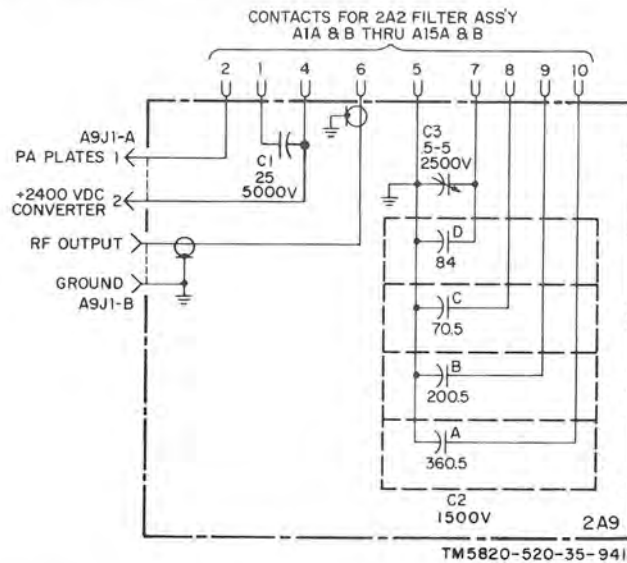

Figure 4-17. AM-3349/GRC-106, stator assembly 2A9, schematic diagram.

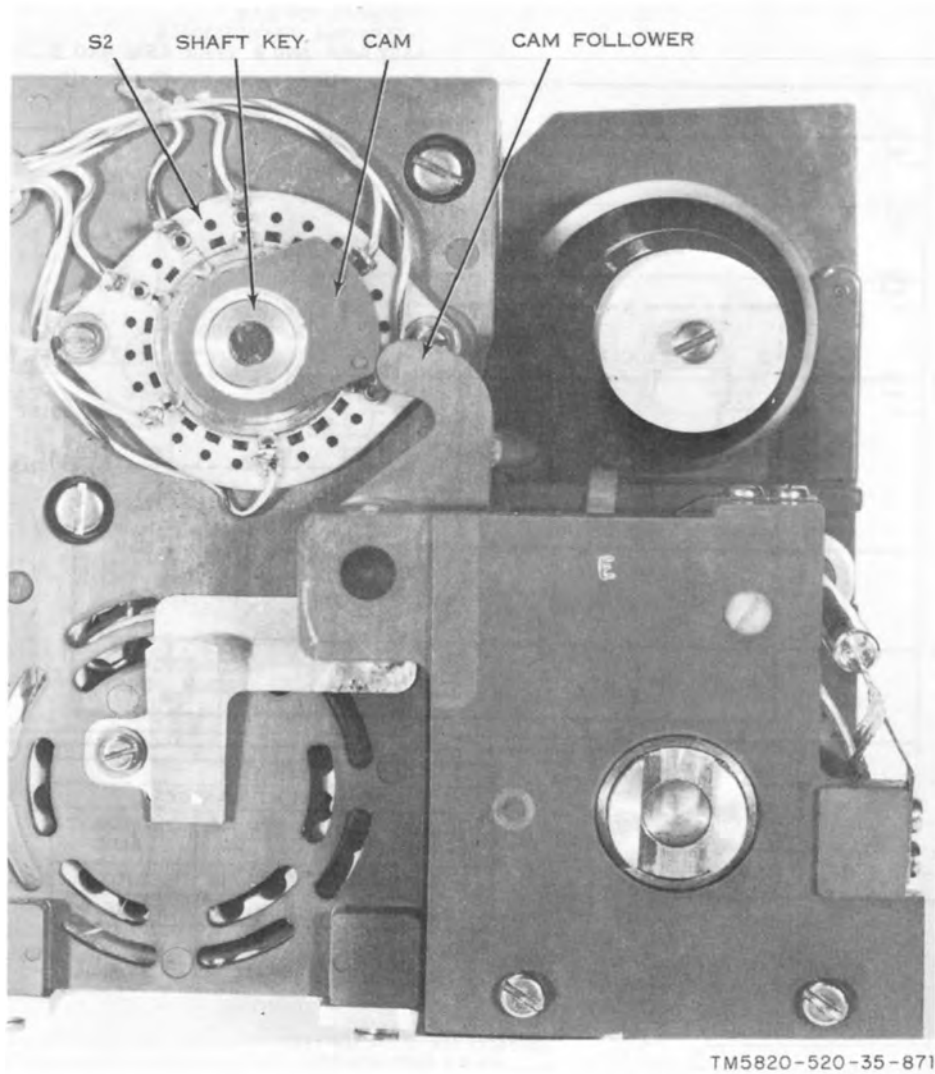
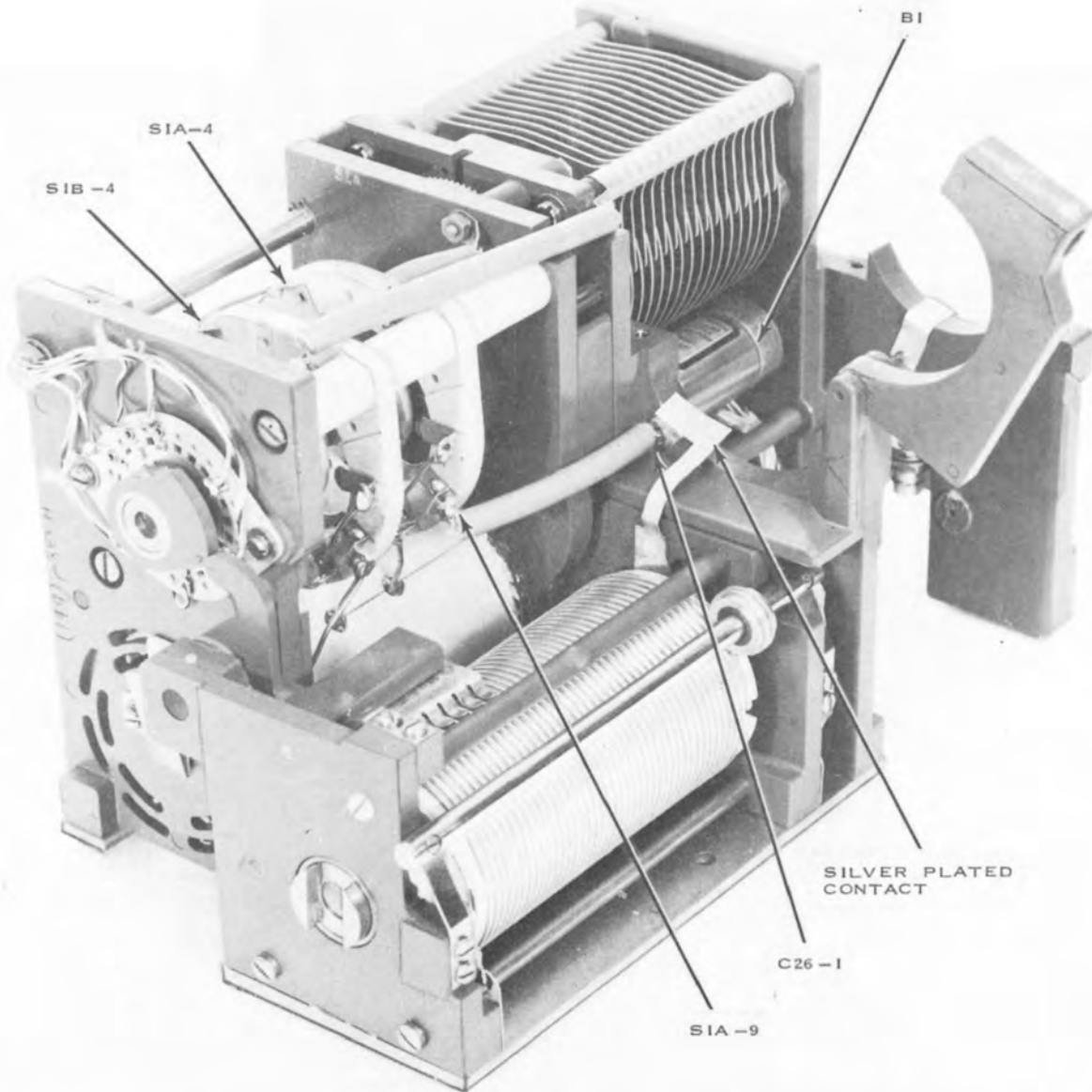

Figure 4-18. Antenna coupler assembly 2A3, cam and cam follower detail.



TM5820-520-35-872

Figure 4-19. Antenna coupler assembly 2A3, parts location, C26 removed.

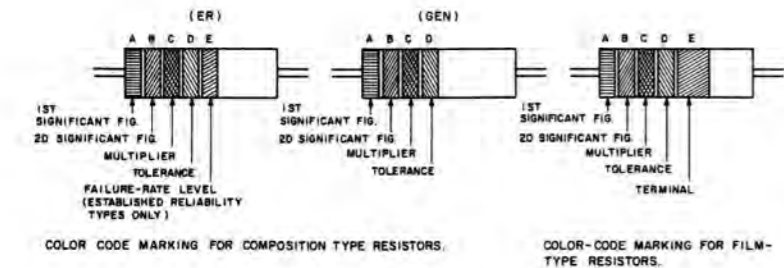

TABLE 1
COLOR CODE FOR COMPOSITION TYPE AND FILM TYPE RESISTORS.

BAND A		BAND B		BAND C		BAND D		BAND E	
COLOR	FIRST SIGNIFICANT FIGURE	COLOR	SECOND SIGNIFICANT FIGURE	COLOR	MULTIPLIER	COLOR	RESISTANCE TOLERANCE (PERCENT)	COLOR	FAILURE RATE LEVEL
BLACK	0	BLACK	0	BLACK	1	BROWN	M±1.0	BROWN	M±1.0
BROWN	1	BROWN	1	BROWN	10	RED	P±0.1	RED	P±0.1
RED	2	RED	2	RED	100	ORANGE	R±0.01	ORANGE	R±0.01
ORANGE	3	ORANGE	3	ORANGE	1,000	YELLOW	S±0.001	YELLOW	S±0.001
YELLOW	4	YELLOW	4	YELLOW	10,000	SILVER	±10 (COMP. TYPE ONLY)	WHITE	SOLD-ERABLE
GREEN	5	GREEN	5	GREEN	100,000	GOLD	±5		
BLUE	6	BLUE	6	BLUE	1,000,000	RED	±2 (NOT APPLICABLE TO ESTABLISHED RELIABILITY)		
PURPLE (VIOLET)	7	PURPLE (VIOLET)	7						
GRAY	8	GRAY	8	SILVER	1.01				
WHITE	9	WHITE	9	GOLD	0.1				

BAND A — THE FIRST SIGNIFICANT FIGURE OF THE RESISTANCE VALUE (BANDS A THRU D SHALL BE OF EQUAL WIDTH.)
 BAND B — THE SECOND SIGNIFICANT FIGURE OF THE RESISTANCE VALUE
 BAND C — THE MULTIPLIER (THE MULTIPLIER IS THE FACTOR BY WHICH THE TWO SIGNIFICANT FIGURES ARE MULTIPLIED TO YIELD THE NOMINAL RESISTANCE VALUE.)
 BAND D — THE RESISTANCE TOLERANCE
 BAND E — WHEN USED ON COMPOSITION RESISTORS, BAND E INDICATES ESTABLISHED RELIABILITY FAILURE-RATE LEVEL (PERCENT FAILURE PER 1,000 HOURS). ON FILM RESISTORS, THIS BAND SHALL BE APPROXIMATELY 1/2 TIMES THE WIDTH OF OTHER BANDS, AND INDICATES TYPE OF TERMINAL.

RESISTANCES IDENTIFIED BY NUMBERS AND LETTERS (THESE ARE NOT COLOR CODED)
 SOME RESISTORS ARE IDENTIFIED BY THREE OR FOUR DIGIT ALPHA NUMERIC DESIGNATORS. THE LETTER R IS USED IN PLACE OF A DECIMAL POINT WHEN FRACTIONAL VALUES OF AN OHM ARE EXPRESSED. FOR EXAMPLE:
 2R7 = 2.7 OHMS 10R0 = 10.0 OHMS

FOR WIRE-WOUND-TYPE RESISTORS COLOR CODING IS NOT USED, IDENTIFICATION MARKING IS SPECIFIED IN EACH OF THE APPLICABLE SPECIFICATIONS.

EXAMPLES OF COLOR CODING

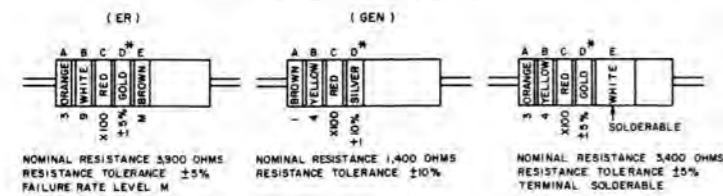

COMPOSITION-TYPE RESISTORS
 * IF BAND D IS OMITTED, THE RESISTOR TOLERANCE IS ±20% AND THE RESISTOR IS NOT MIL-STD
 A. COLOR CODE MARKING FOR MILITARY STANDARD RESISTORS.

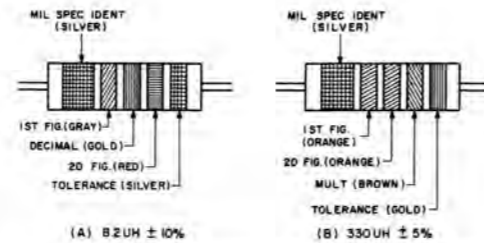

COLOR CODING FOR TUBULAR ENCAPSULATED R.F. CHOKES.

TABLE 2
COLOR CODING FOR TUBULAR ENCAPSULATED R.F. CHOKES.

COLOR	SIGNIFICANT FIGURE	MULTIPLIER	INDUCTANCE TOLERANCE (PERCENT)
BLACK	0	1	
BROWN	1	10	1
RED	2	100	2
ORANGE	3	1,000	3
YELLOW	4		
GREEN	5		
BLUE	6		
VIOLET	7		
GRAY	8		
WHITE	9		
NONE			20
SILVER			10
GOLD			5

MULTIPLIER IS THE FACTOR BY WHICH THE TWO COLOR FIGURES ARE MULTIPLIED TO OBTAIN THE INDUCTANCE VALUE OF THE CHOKE COIL.

B. COLOR CODE MARKING FOR MILITARY STANDARD INDUCTORS.

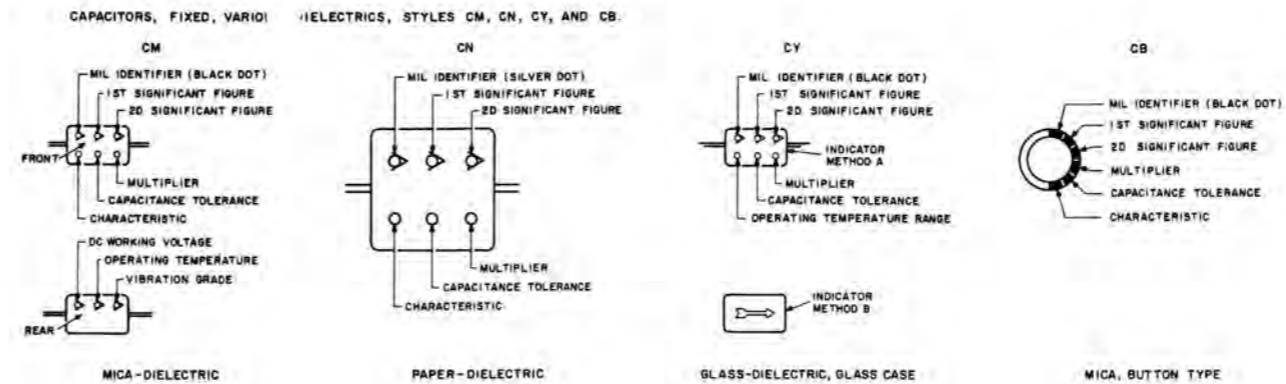

TABLE 3 — FOR USE WITH STYLES CM, CN, CY AND CB.

COLOR	MIL ID	1ST SIG FIG	2D SIG FIG	MULTIPLIER	CAPACITANCE TOLERANCE				CHARACTERISTIC	DC WORKING VOLTAGE	OPERATING TEMP RANGE	VIBRATION GRADE
					CM	CN	CY	CB				
BLACK	CM, CY, CB	0	0	1				±20%	±20%	A	-55° to +70°C	10-55 Hz
BROWN		1	1	10						B, E, B		
RED		2	2	100	±2%			±2%	±2%	C	-55° to +85°C	
ORANGE		3	3	1,000		±50%				D, D	300	
YELLOW		4	4	10,000						E		-55° to +125°C 10-2,000 Hz
GREEN		5	5		±5%					F	300	
BLUE		6	6									-55° to +150°C
PURPLE (VIOLET)		7	7									
GRAY		8	8									
WHITE		9	9									
GOLD				0.1				±5%	±5%			
SILVER	CN				±10%	±10%	±10%	±10%				

TABLE 4 — TEMPERATURE COMPENSATING, STYLE CC.

COLOR	TEMPERATURE COEFFICIENT*	1ST SIG FIG	2D SIG FIG	MULTIPLIER	CAPACITANCE TOLERANCE		MIL ID
					CAPACITANCES OVER 10 UUF	CAPACITANCES 10 UUF OR LESS	
BLACK	0	0	0	1		±2.0 UUF	CC
BROWN	-30	1	1	10	±1%		
RED	-80	2	2	100	±2%	±0.25 UUF	
ORANGE	-150	3	3	1,000			
YELLOW	-220	4	4				
GREEN	-350	5	5		±5%	±0.5 UUF	
BLUE	-470	6	6				
PURPLE (VIOLET)	-750	7	7				
GRAY		8	8	0.01			
WHITE		9	9	0.1	±10%		
GOLD	+100					±1.0 UUF	
SILVER							

* THE MULTIPLIER IS THE NUMBER BY WHICH THE TWO SIGNIFICANT FIGURES ARE MULTIPLIED TO OBTAIN THE CAPACITANCE IN UUF.
 2. LETTERS INDICATE THE CHARACTERISTICS DESIGNATED IN APPLICABLE SPECIFICATIONS: MIL-C-5, MIL-C-250, MIL-C-11272B, AND MIL-C-10950C RESPECTIVELY.
 3. LETTERS INDICATE THE TEMPERATURE RANGE AND VOLTAGE-TEMPERATURE LIMITS DESIGNATED IN MIL-C-11015D.
 4. TEMPERATURE COEFFICIENT IN PARTS PER MILLION PER DEGREE CENTIGRADE.

C. COLOR CODE MARKING FOR MILITARY STANDARD CAPACITORS.

Figure 4-20. Resistor, inductor, and capacitor color code charts.

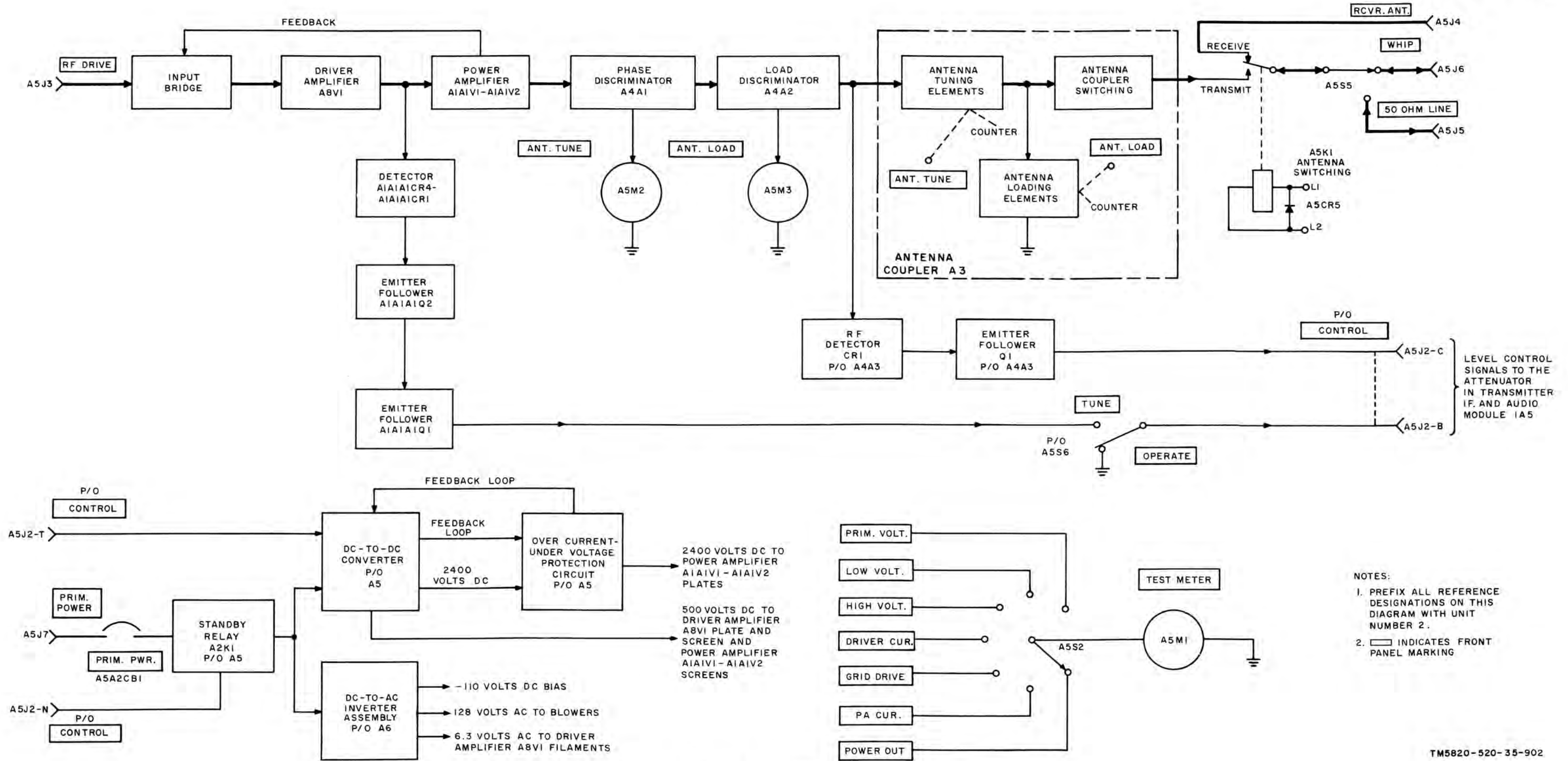

- NOTES:
1. PREFIX ALL REFERENCE DESIGNATIONS ON THIS DIAGRAM WITH UNIT NUMBER 2.
 2. INDICATES FRONT PANEL MARKING

Figure 4-21. Amplifier, Radio Frequency AM-3349/GRC-106, functional block diagram.

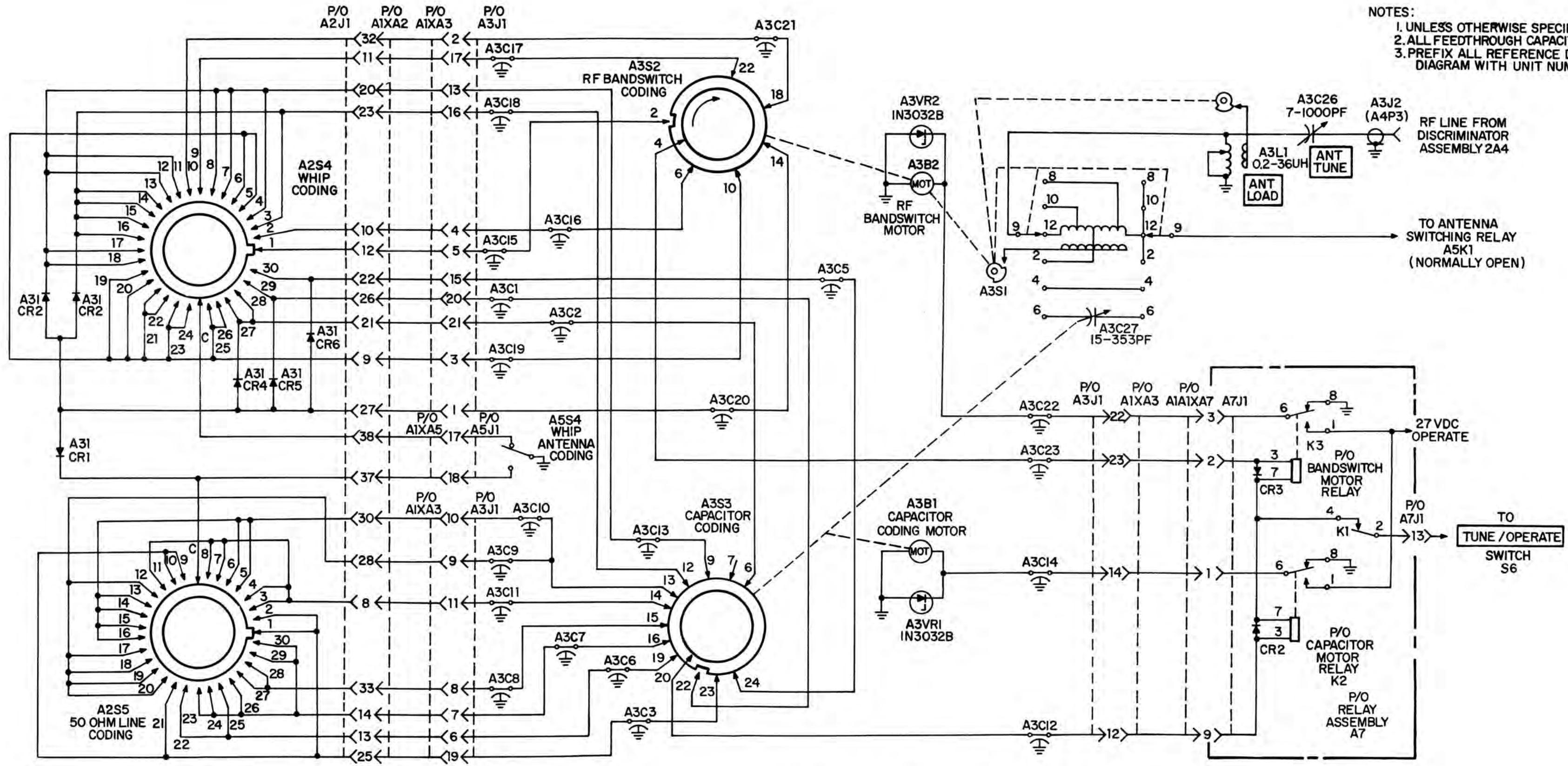

- NOTES:
 1. UNLESS OTHERWISE SPECIFIED ALL DIODES IN647
 2. ALL FEEDTHROUGH CAPACITORS ARE 0.001UF.
 3. PREFIX ALL REFERENCE DESIGNATIONS ON THIS DIAGRAM WITH UNIT NUMBER 2.

TURRET POSITION	OPERATING FREQ MHZ
1	2-2.5
2	3-3.5
3	14-15
4	15-16
5	24-25
6	25-26
7	16-17
8	17-18
9	2.5-3
10	3.5-4
11	18-19
12	19-20
13	26-27
14	27-28
15	28-29
16	29-30
17	20-21
18	21-22
19	22-23
20	23-24
21	4-5
22	5-6
23	8-9
24	9-10
25	6-7
26	7-8
27	12-13
28	13-14
29	10-11
30	11-12

Figure 4-22. Antenna coupler assembly 2A3, tuning controls.

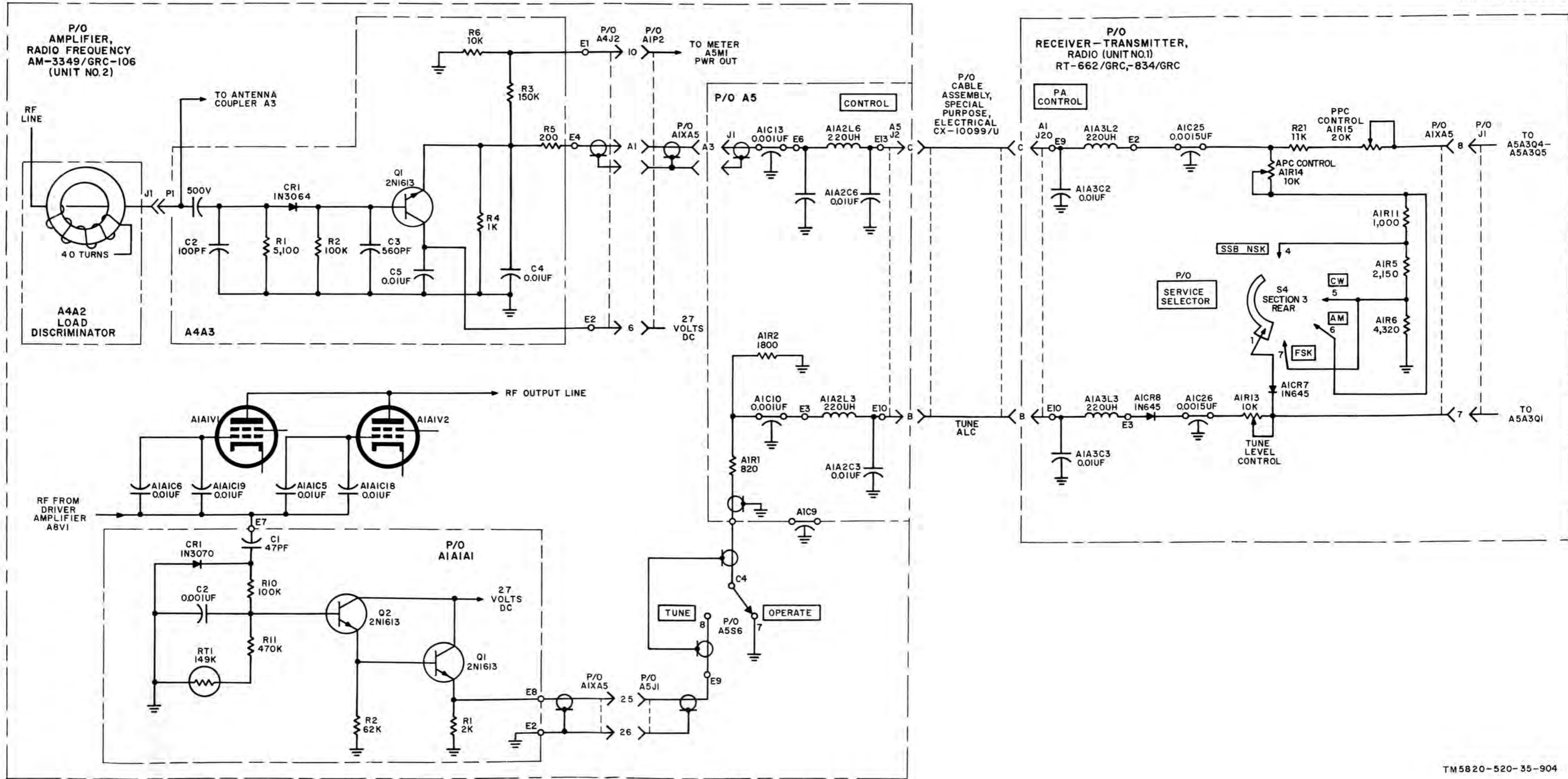

Figure 4-23. Level control signals, interunit circuit details.

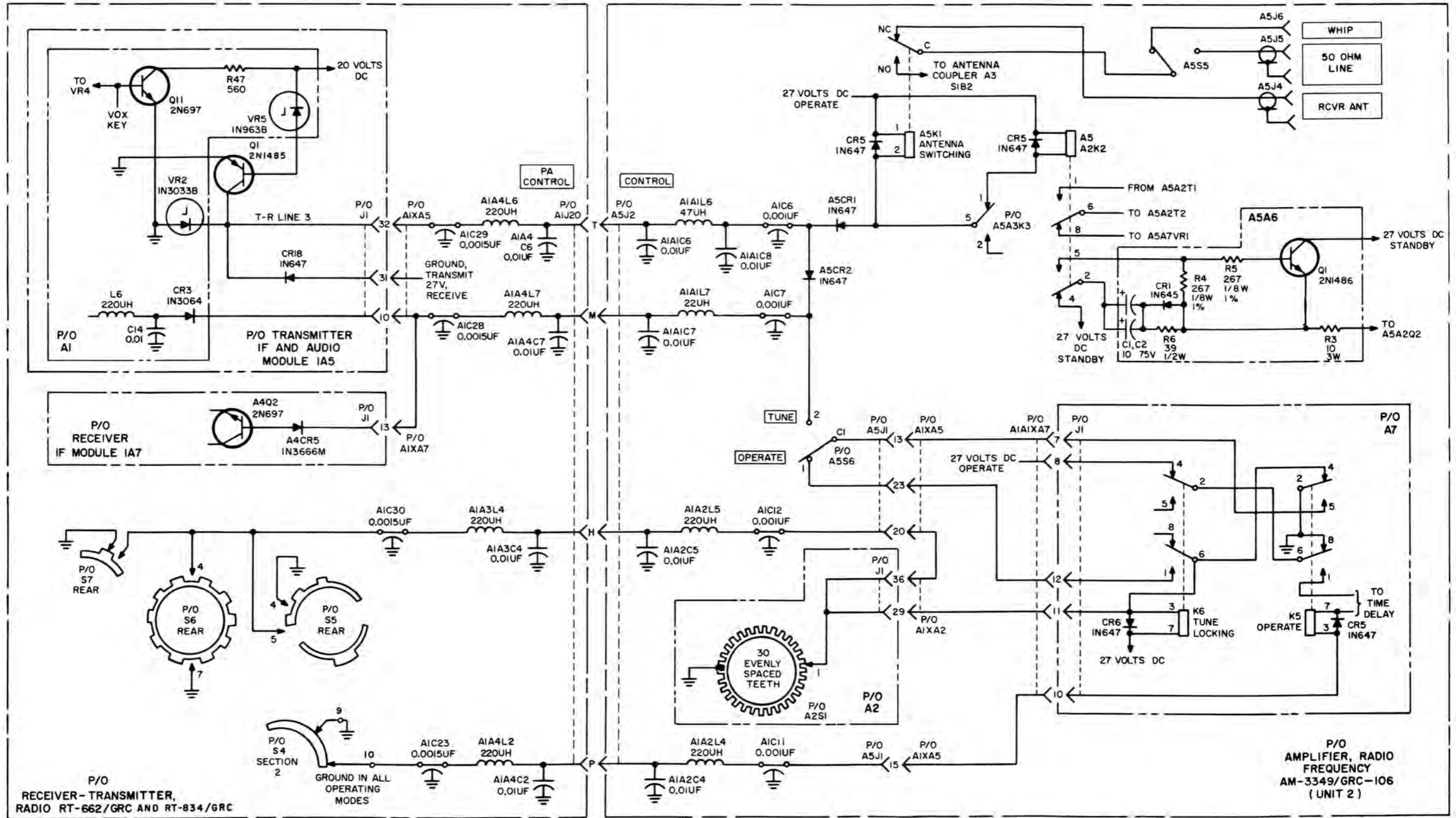

Figure 4-25. Keying interunit circuit details for AN/GRC-106(*).

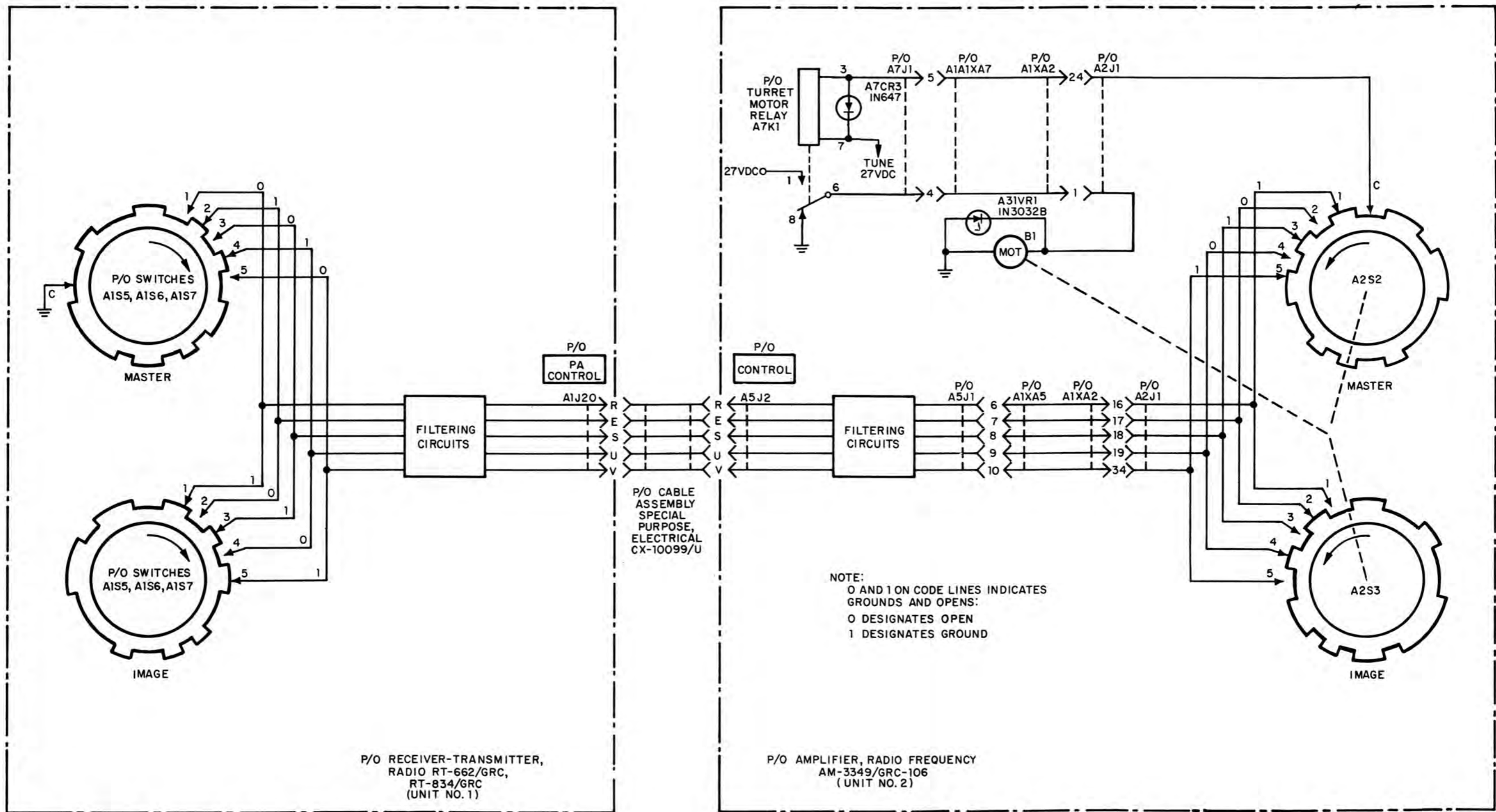
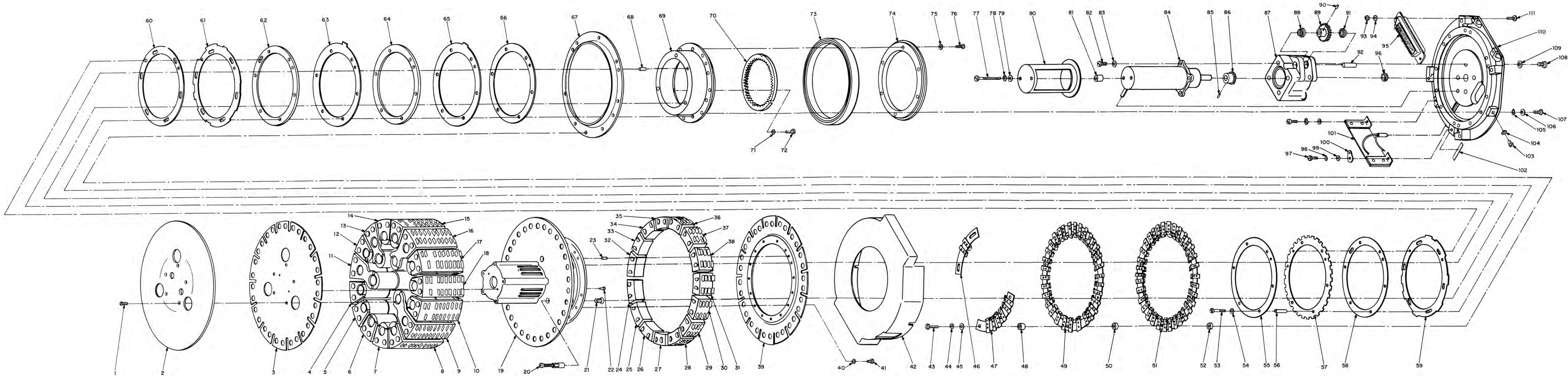

Figure 4-26. Tuning interunit circuit details for AN/GRC-106(*).



- 1 6-32 screw (5/16 long)
- 2 Locking plate
- 3 Mounting plate
- 4 Filter assembly A10
- 5 Filter assembly A9
- 6 Filter assembly A8
- 7 Filter assembly A7
- 8 Filter assembly A6
- 9 Filter assembly A5
- 10 Filter assembly A4
- 11 Filter assembly A11
- 12 Filter assembly A12
- 13 Filter assembly A13
- 14 Filter assembly A14
- 15 Filter assembly A15
- 16 Filter assembly A1
- 17 Filter assembly A2
- 18 Filter assembly A3
- 19 Turret drum base
- 20 Captive screw
- 21 Retainer nut
- 22 Rivet
- 23 Spiral locating pin
- 24 Transformer assembly A25
- 25 Transformer assembly A24
- 26 Transformer assembly A23
- 27 Transformer assembly A22
- 28 Transformer assembly A21
- 29 Transformer assembly A20
- 30 Transformer assembly A19
- 31 Transformer assembly A18
- 32 Transformer assembly A26
- 33 Transformer assembly A27
- 34 Transformer assembly A28
- 35 Transformer assembly A29
- 36 Transformer assembly A30
- 37 Transformer assembly A16
- 38 Transformer assembly A17
- 39 Mounting ring
- 40 No. 4 flat washer
- 41 4-40 screw (0.168 long)
- 42 Turret base cover
- 43 4-40 screw (3/4 long)
- 44 No. 4 lockwasher
- 45 No. 4 flat washer
- 46 S1 contact assembly
- 47 S2 (top)/S3 (bottom) contact assembly
- 48 Spacer
- 49 S4 contact assembly
- 50 Spacer
- 51 S5 contact assembly
- 52 Spacer
- 53 40-40 screw (7/8 long)
- 54 No. 4 flat washer
- 55 Locking ring
- 56 Insulator bushing
- 57 S1 rotor
- 58 Insulator ring
- 59 S2 rotor
- 60 Insulator ring
- 61 S3 rotor
- 62 Insulator ring
- 63 S4 rotor
- 64 Insulator ring
- 65 S5 rotor
- 66 Insulator ring
- 67 Ring bearing retainer
- 68 Locating pin
- 69 Turret mount
- 70 120-tooth internal gear assembly
- 71 No. 6 flat washer
- 72 6-32 screw (3/8 long)
- 73 Ring bearing
- 74 Ring bearing retainer
- 75 No. 6 flat washer
- 76 6-32 screw (3/8 long)
- 77 4-40 screw (1-1/4 long)
- 78 No. 4 lock washer
- 79 No. 4 flat washer
- 80 Motor cover
- 81 Spacer
- 82 6-32 screw (3/8 long)
- 83 No. 6 flat washer
- 84 Turret motor
- 85 Spiral pin
- 86 28-tooth spur gear
- 87 Motor mount
- 88 Ball bearing
- 89 46-tooth spur gear
- 90 Spiral pin
- 91 Ball bearing
- 92 Gear shaft
- 93 4-40 nut
- 94 No. 4 flat washer
- 95 Connector
- 96 Ball bearing
- 97 6-32 screw (5/16 long)
- 98 No. 6 lock washer
- 99 No. 6 flat washer
- 100 Terminal lug
- 101 Coding assembly board
- 102 Channel cover
- 103 6-32 screw (5/8 long)
- 104 No. 6 lockwasher
- 105 No. 6 lockwasher
- 106 No. 6 flat washer
- 107 6-32 screw (7/16 long)
- 108 10-32 screw (1/4 long)
- 109 No. 10 flat washer
- 110 Turret assembly base
- 111 4-40 screw (3/8 long)

Figure 4-27. Amplifier, Radio Frequency AM-3349/GRC-106, turret assembly parts location.



g. 100-KHZ SPECTRUM INPUT
IA2A2E10
0.2 VOLTS/CM
2 MICROSECONDS/CM



b. 100-KHZ CRYSTAL OSCILLATOR OUTPUT PLUS 100-KC SPECTRUM LEAKAGE
IA2A2E15
0.2 VOLTS/CM
10 MICROSECONDS/CM

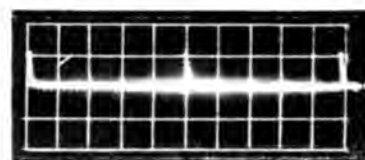

c. 1-KHZ PULSE INPUT
IA4A1E6
1 VOLT/CM
0.2 MILLISECONDS/CM

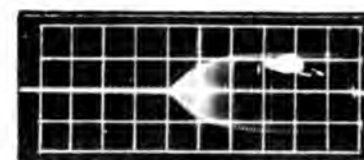

d. 1-KHZ SPECTRUM OUTPUT
IA4A1E9
2 VOLTS/CM
4 MICROSECONDS/CM



e. 1-KHZ SPECTRUM OUTPUT
IA4A1E9
2 VOLTS/CM
0.2 MICROSECONDS/CM

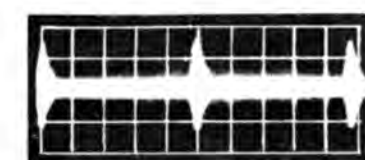

f. 10-KHZ SPECTRUM INPUT
IA4A2E6
0.05 VOLTS/CM
20 MICROSECONDS/CM



g. 1.97-MHZ PLUS 9.07 MC OUTPUT
IA4A2E9
0.05 VOLTS/CM
0.2 MICROSECONDS/CM
(1.981MHZ FOR RT-834/GRC)

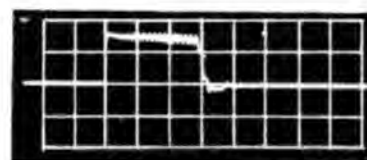

h. 100-KHZ KEYING PULSE
IA6A1E5
0.5 VOLTS/CM
0.4 MICROSECONDS/CM

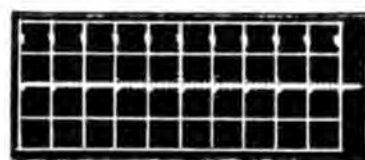

i. 100-KHZ KEYING PULSE
IA6A1E5
0.5 VOLTS/CM
10 MICROSECONDS/CM

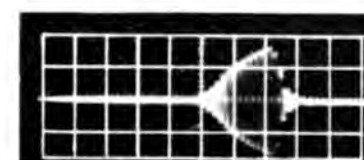

j. 100-KHZ SPECTRUM OUTPUT
IA6A1E6
0.2 VOLTS/CM
0.4 MICROSECONDS/CM

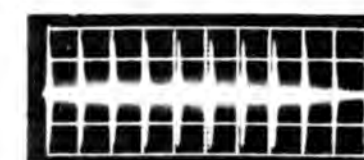

k. 100-KHZ SPECTRUM OUTPUT
IA6A1E6
0.2 VOLTS/CM
10 MICROSECONDS/CM



l. 1.50-KHZ KEYING PULSE
IA6A2E5
1 VOLT/CM
20 MICROSECONDS/CM

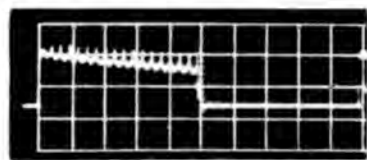

m. 50-KHZ KEYING
IA6A2E5
1 VOLT/CM
2 MICROSECONDS/CM

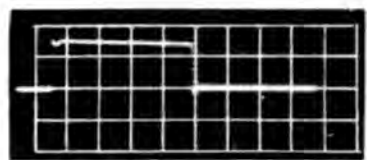

n. 10-KHZ KEY PULSE
IA6A2E6
0.5 VOLTS/CM
2 MICROSECONDS/CM

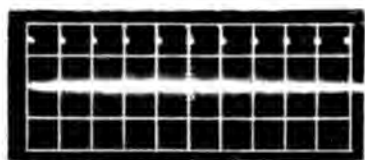

o. 10-KHZ KEYING PULSE
IA6A2E6
0.5 VOLTS/CM
0.1 MILLISECONDS/CM

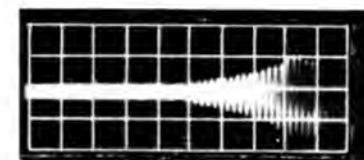

p. 10-KHZ SPECTRUM OUTPUT
FREQ VERNIER - OFF
IA6A2E13
0.05 VOLTS/CM
2 MICROSECONDS/CM

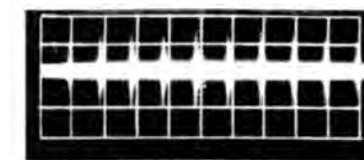

q. 10-KHZ SPECTRUM OUTPUT
FREQ VERNIER - OFF
IA6A2E13
0.05 VOLTS/CM
0.1 MILLISECONDS/CM

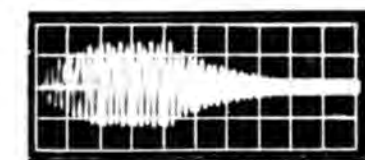

r. 10-KHZ SPECTRUM OUTPUT
FREQ VERNIER - ON
IA6A2E13
0.05 VOLTS/CM
2 MICROSECONDS/CM

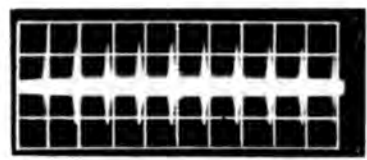

s. 10-KHZ SPECTRUM OUTPUT
FREQ VERNIER - ON
IA6A2E13
0.05 VOLTS/CM
0.1 MILLISECONDS/CM

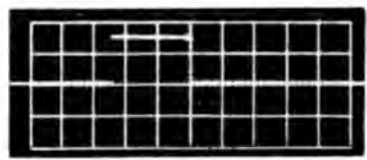

t. 1-KHZ PULSE OUTPUT
IA6A3E5
1 VOLT/CM
40 MICROSECONDS/CM

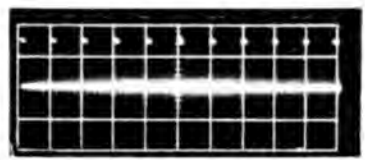

u. 1-KHZ PULSE OUTPUT
IA6A3E5
1 VOLT/CM
1 MILLISECONDS/CM

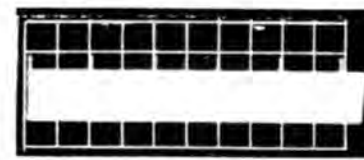

v. 1-MHZ PULSE INPUT PLUS MHz CRYSTAL OSCILLATOR LEAKAGE
IA9A1E4
0.2 VOLTS/CM
1 MICROSECONDS/CM



w. 1.5-MHZ IF OUTPUT
IA9A2E3
0.2 VOLTS/CM
0.5 MICROSECONDS/CM

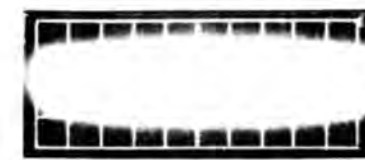

x. TRANSMIT 1.75-MHZ IF TWO-TONE INPUT
IA8A1E1
0.05 VOLTS/CM
1 MICROSECOND/CM

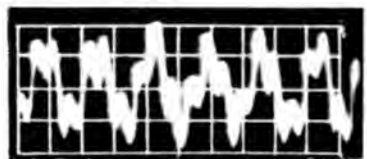

y. TRANSMIT LF MIXER OUTPUT
IA8A1E6
0.05 VOLTS/CM
0.2 MICROSECONDS/CM



z. TRANSMIT 2.85-MHZ IF OUTPUT
IA8A2E1
0.05 VOLTS/CM
0.2 MICROSECONDS/CM



aa. TRANSMIT MF MIXER OUTPUT
IA8A2E10
0.1 VOLTS/CM
0.1 MICROSECONDS/CM

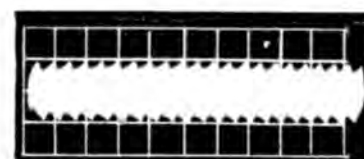

bb. TRANSMIT 20-MHZ IF OUTPUT
IA8A3E3
0.05 VOLTS/CM
0.1 MICROSECONDS/CM



cc. TRANSMIT TWO-TONE RF OUTPUT
IA8A3E17
0.2 VOLTS/CM
2 MILLISECONDS/CM

NOTES:

1. ALL MEASUREMENTS WERE MADE WITH OSCILLOSCOPE AN/USM-81
2. SECTIONS g,d,j,p, ARE MIRROR IMAGES
3. ALL MEASUREMENTS ON TRANSLATOR MODULE IAB WERE MADE AT AN OPERATING FREQUENCY OF 8MC AND A 5MV INPUT AT AUDIO CONNECTOR

Figure 4-28. Receiver-Transmitter, Radio RT-662/GRC and RT-834/GRC, waveform diagram.

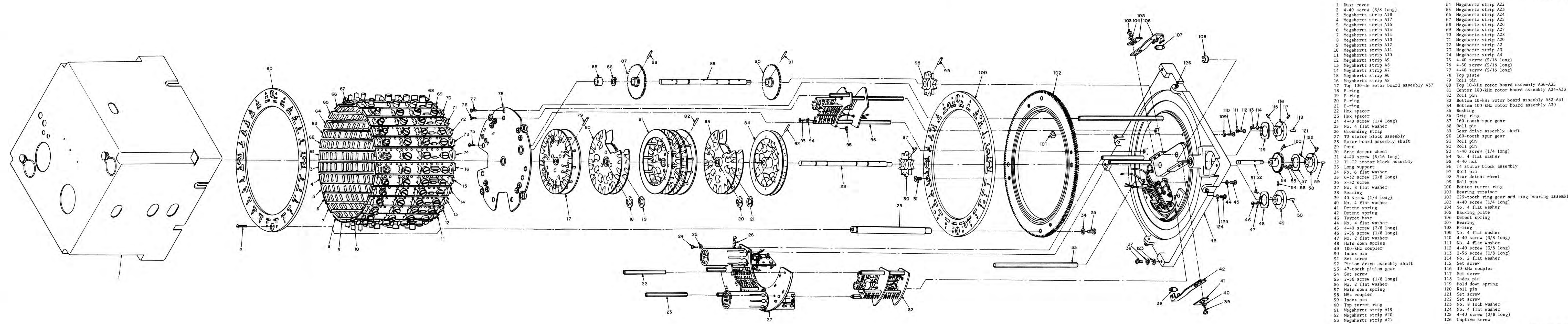

- 1 Dust cover
- 2 4-40 screw (3/8 long)
- 3 Megahertz strip A18
- 4 Megahertz strip A17
- 5 Megahertz strip A16
- 6 Megahertz strip A15
- 7 Megahertz strip A14
- 8 Megahertz strip A13
- 9 Megahertz strip A12
- 10 Megahertz strip A11
- 11 Megahertz strip A10
- 12 Megahertz strip A9
- 13 Megahertz strip A8
- 14 Megahertz strip A7
- 15 Megahertz strip A6
- 16 Megahertz strip A5
- 17 Top 100-kHz rotor board assembly A37
- 18 E-ring
- 19 E-ring
- 20 E-ring
- 21 E-ring
- 22 Hex spacer
- 23 Hex spacer
- 24 4-40 screw (1/4 long)
- 25 No. 4 flat washer
- 26 Grounding strap
- 27 T3 stator block assembly
- 28 Rotor board assembly shaft
- 29 Post
- 30 Star detent wheel
- 31 4-40 screw (5/16 long)
- 32 T1-T2 stator block assembly
- 33 Long support
- 34 No. 6 flat washer
- 35 6-32 screw (3/8 long)
- 36 8-32 screw
- 37 No. 8 flat washer
- 38 Bearing
- 39 40 screw (1/4 long)
- 40 No. 4 flat washer
- 41 Detent spring
- 42 Detent spring
- 43 Turret base
- 44 No. 4 flat washer
- 45 4-40 screw (3/8 long)
- 46 2-56 screw (1/8 long)
- 47 No. 2 flat washer
- 48 Hold down spring
- 49 100-kHz coupler
- 50 Index pin
- 51 Set screw
- 52 Pinion drive assembly shaft
- 53 47-tooth pinion gear
- 54 Set screw
- 55 2-56 screw (1/8 long)
- 56 No. 2 flat washer
- 57 Hold down spring
- 58 MHz coupler
- 59 Index pin
- 60 Top turret ring
- 61 Megahertz strip A19
- 62 Megahertz strip A20
- 63 Megahertz strip A21
- 64 Megahertz strip A22
- 65 Megahertz strip A23
- 66 Megahertz strip A24
- 67 Megahertz strip A25
- 68 Megahertz strip A26
- 69 Megahertz strip A27
- 70 Megahertz strip A28
- 71 Megahertz strip A29
- 72 Megahertz strip A2
- 73 Megahertz strip A3
- 74 Megahertz strip A4
- 75 4-40 screw (5/16 long)
- 76 4-50 screw (5/16 long)
- 77 4-40 screw (5/16 long)
- 78 Top plate
- 79 Roll pin
- 80 Top 10-kHz rotor board assembly A36-A35
- 81 Center 100-kHz rotor board assembly A34-A33
- 82 Roll pin
- 83 Bottom 10-kHz rotor board assembly A32-A31
- 84 Bottom 100-kHz rotor board assembly A30
- 85 Bushing
- 86 Grip ring
- 87 160-tooth spur gear
- 88 Roll pin
- 89 Gear drive assembly shaft
- 90 160-tooth spur gear
- 91 Roll pin
- 92 Roll pin
- 93 4-40 screw (1/4 long)
- 94 No. 4 flat washer
- 95 4-40 nut
- 96 T4 stator block assembly
- 97 Roll pin
- 98 Star detent wheel
- 99 Roll pin
- 100 Bottom turret ring
- 101 Bearing retainer
- 102 329-tooth ring gear and ring bearing assembly
- 103 4-40 screw (1/4 long)
- 104 No. 4 flat washer
- 105 Backing plate
- 106 Detent spring
- 107 Bearing
- 108 E-ring
- 109 No. 4 flat washer
- 110 4-40 screw (3/8 long)
- 111 No. 4 flat washer
- 112 4-40 screw (3/8 long)
- 113 2-56 screw (1/8 long)
- 114 No. 2 flat washer
- 115 Set screw
- 116 10-kHz coupler
- 117 Set screw
- 118 Index pin
- 119 Hold down spring
- 120 Roll pin
- 121 Set screw
- 122 Set screw
- 123 No. 8 lock washer
- 124 No. 4 flat washer
- 125 4-40 screw (3/8 long)
- 126 Captive screw

Figure 4-29. Rf amplifier module 1A12, exploded view parts location diagram.

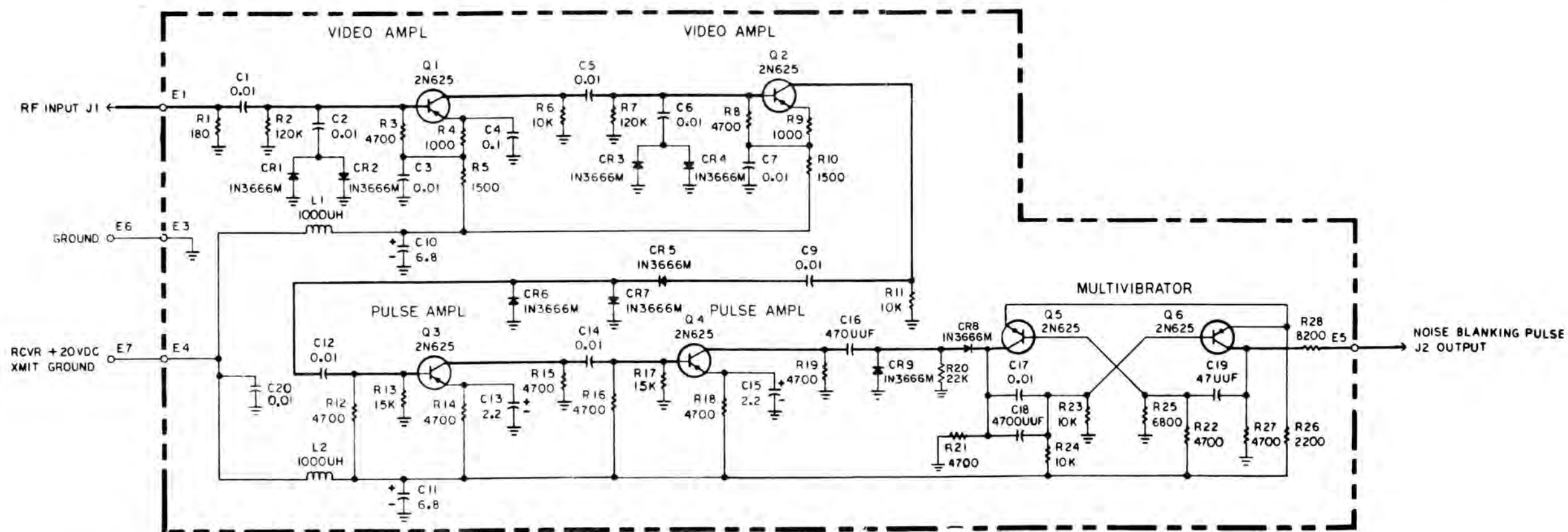

- NOTES:
1. UNLESS OTHERWISE SPECIFIED, RESISTANCES ARE IN OHMS, $\pm 5\%$, 1/4 W, CAPACITANCES ARE IN UF.
 2. PARTIAL REFERENCE DESIGNATIONS ARE SHOWN, FOR COMPLETE DESIGNATION PREFIX WITH IA1A5.

TM5820-520-35-914

Figure 4-30. RT-662/GRC (Serial Numbers 1 through 220, Order No. FR-36-039-B-6-31886(E)) noise blanker assembly 1A1A6, schematic diagram.

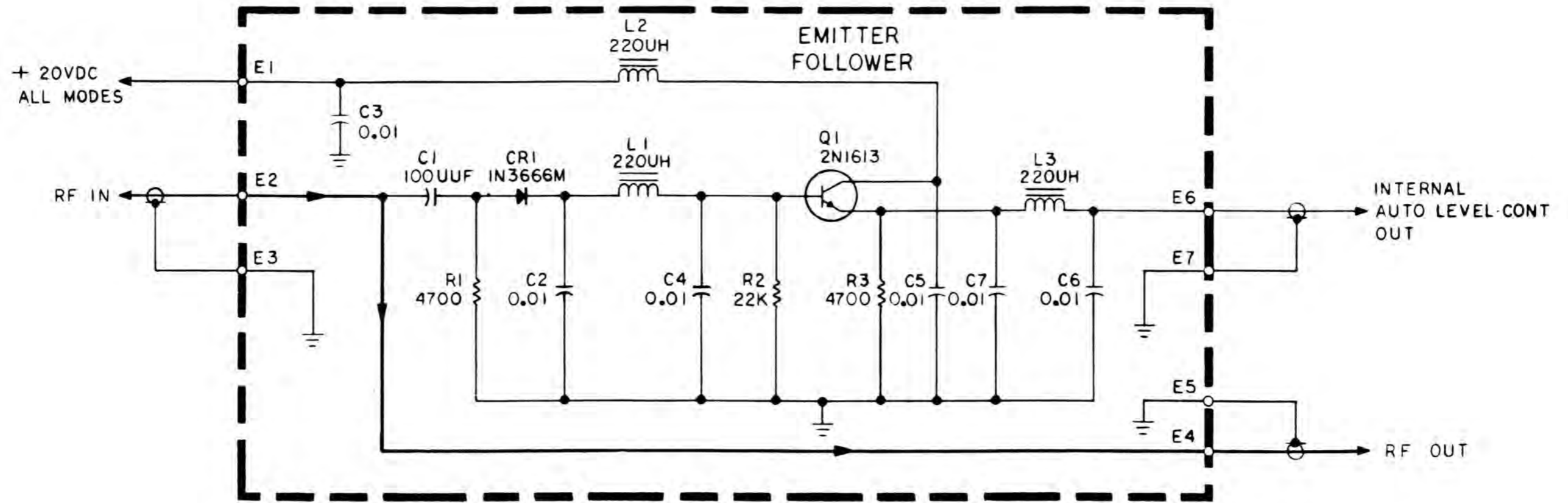

NOTES:

1. PARTIAL REFERENCE DESIGNATIONS ARE SHOWN; FOR COMPLETE DESIGNATION PREFIX WITH IAIA5.
2. UNLESS OTHERWISE SPECIFIED:
 ALL RESISTOR VALUES ARE IN OHMS
 ALL RESISTORS ARE 1/4W 5%
 ALL CAPACITOR VALUES ARE IN MICROFARADS

Figure 4-31. Receiver-Transmitter, Radio RT-662/GRC and RT-834/GRC, internal ALC assembly 1A1A2A5, schematic diagram.

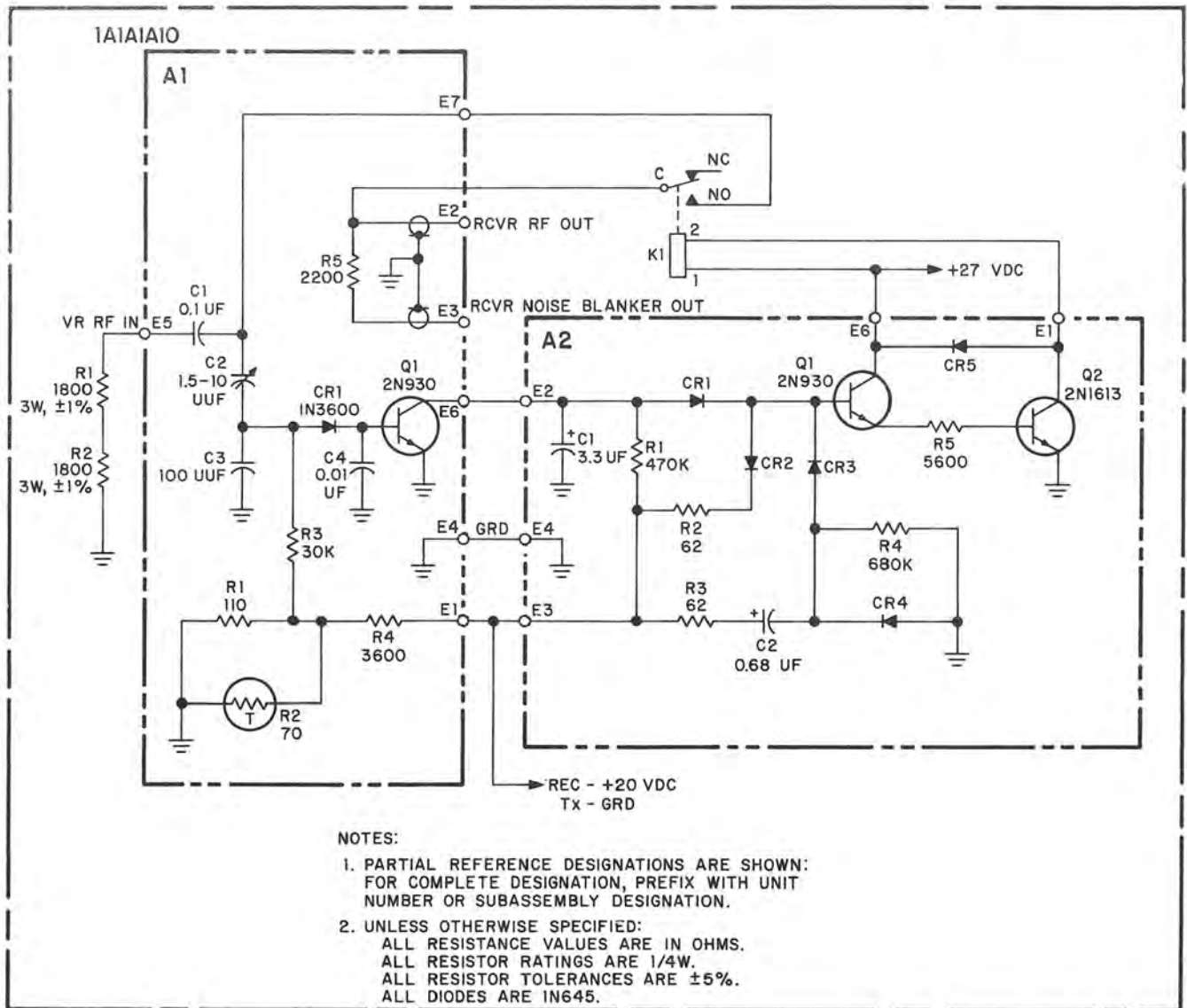

TM 5820-520-35-916

Figure 4-32. Receiver-Transmitter, Radio RT-662/GRC, and RT-834/GRC, front end protection circuit 1A1A1A10, schematic diagram.

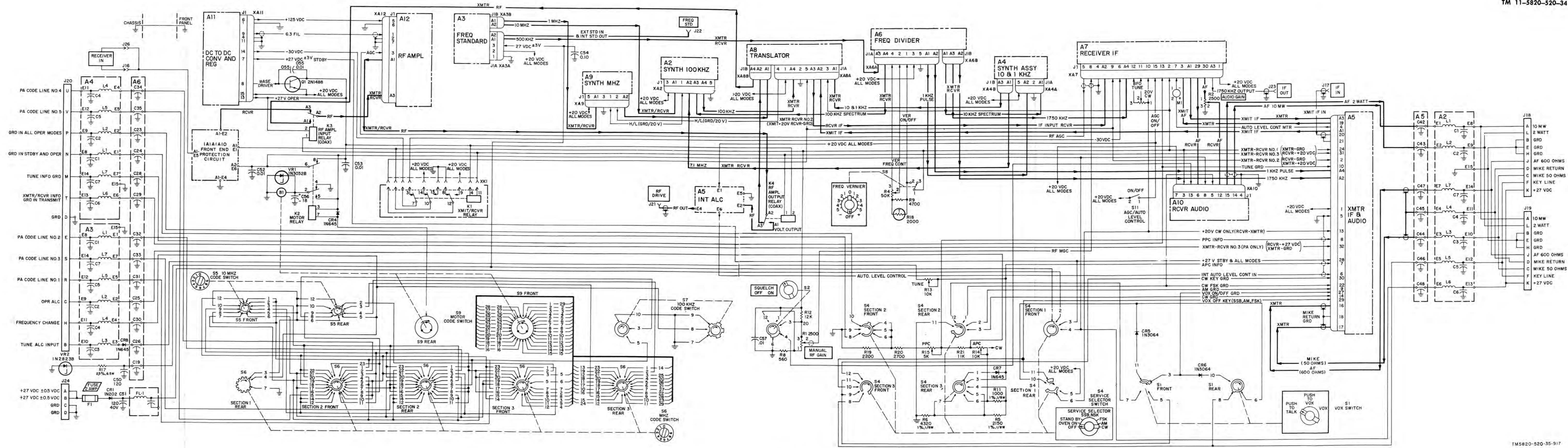

Figure 4-33. Receiver-Transmitter, Radio RT-662/GRC, front panel and chassis 1A1, schematic diagram.

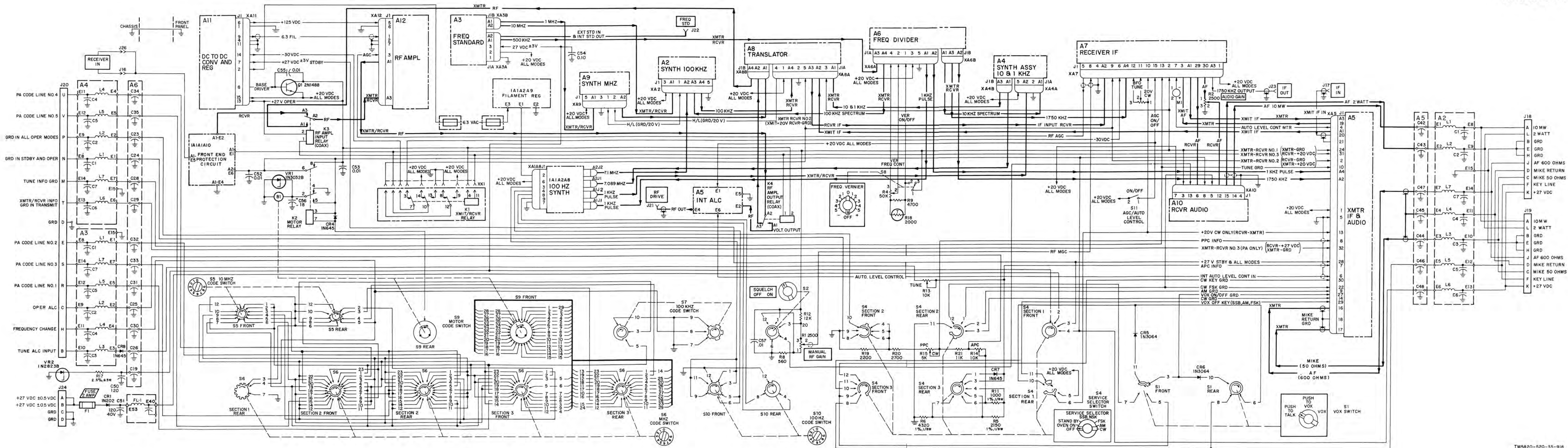

Figure 4-34. Receiver-Transmitter, Radio RT-831/GRC, front panel and chassis 1A1, schematic diagram.

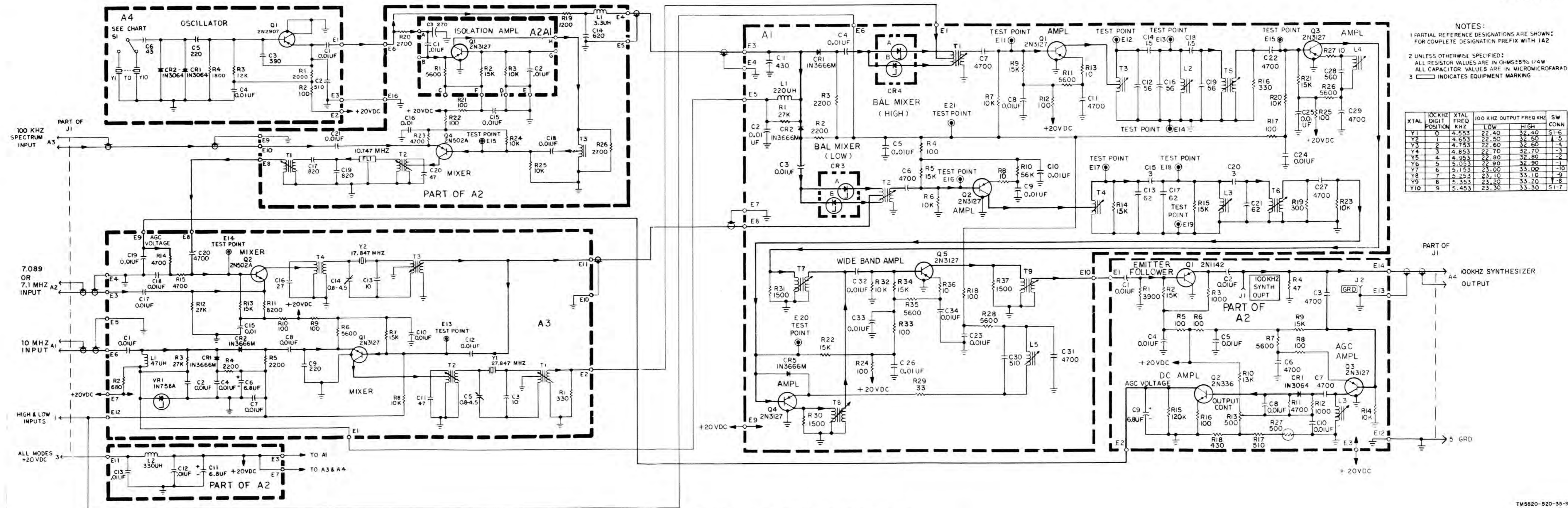

Figure 4-35. Receiver-Transmitter, Radio RT-662/GRC and RT-834/GRC, 100 kHz synthesizer module 1A2, schematic diagram.

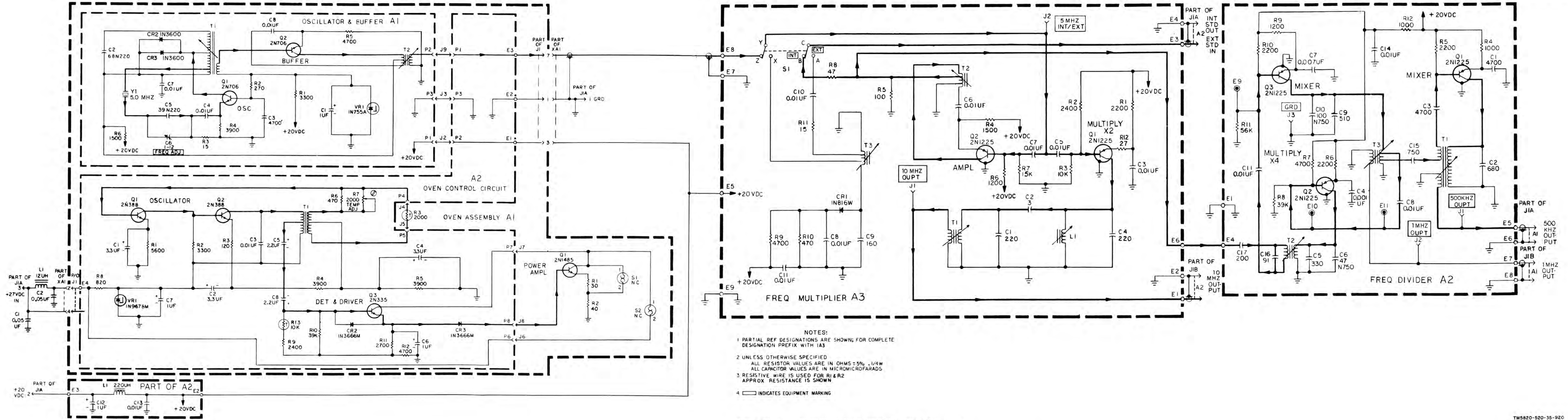

Figure 4-36. Receiver-Transmitter, Radio RT-662/GRC, RT-834/GRC, frequency standard module 1A3, schematic diagram.

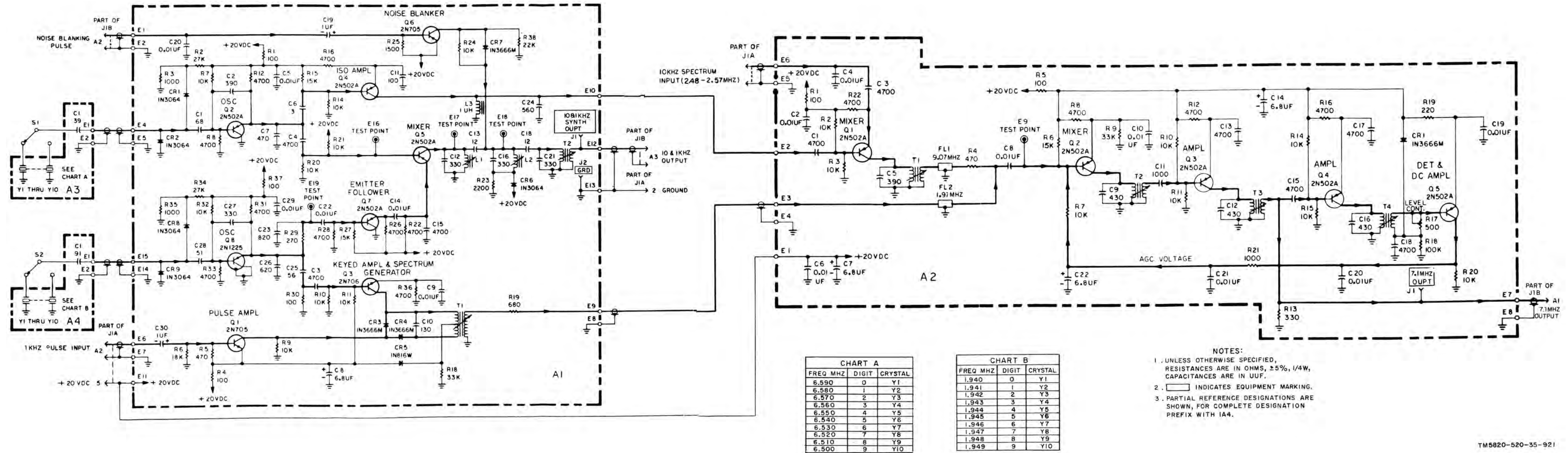
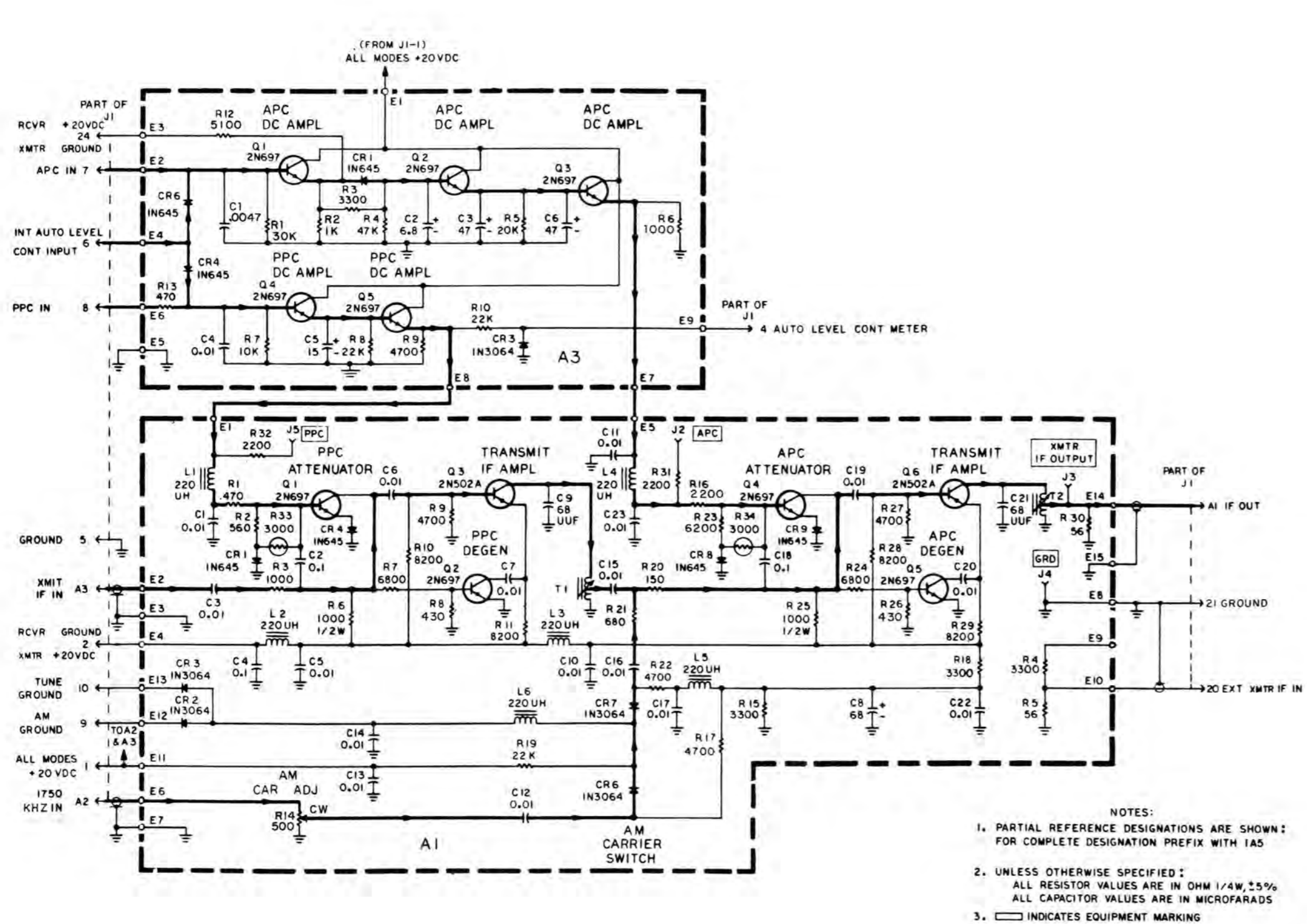

Figure 4-37. Receiver-Transmitter, Radio RT-662/GRC (Serial Numbers 1 through 220, Order No. FR-36-039-B-6-31886(E)) 10- and 1-kHz synthesizer module 1A4, schematic diagram.



- NOTES:
1. PARTIAL REFERENCE DESIGNATIONS ARE SHOWN FOR COMPLETE DESIGNATION PREFIX WITH 1A5
 2. UNLESS OTHERWISE SPECIFIED: ALL RESISTOR VALUES ARE IN OHM 1/4W, 5% ALL CAPACITOR VALUES ARE IN MICROFARADS
 3. INDICATES EQUIPMENT MARKING

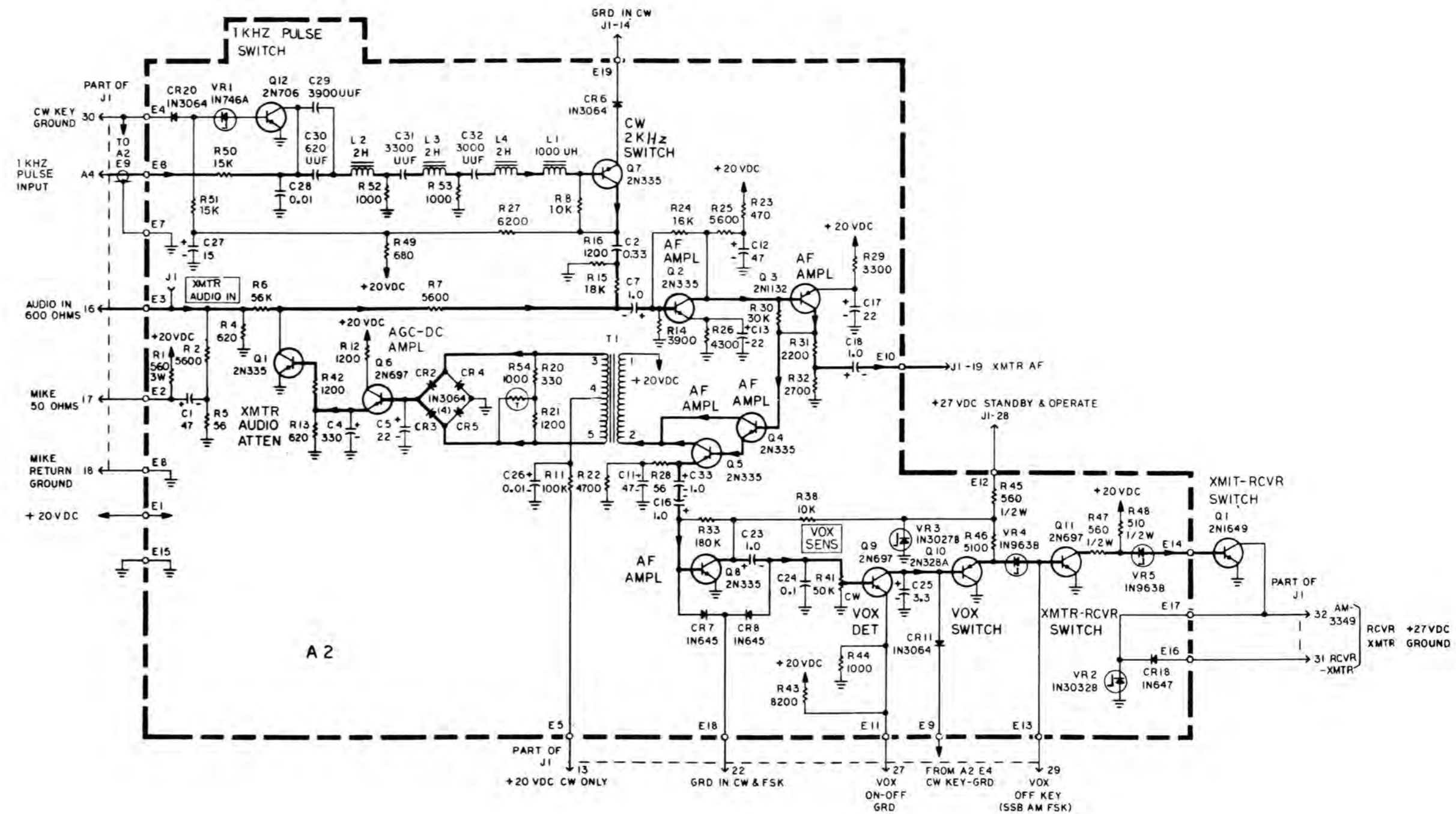

Figure 4-39. Receiver-Transmitter, Radio RT-662/GRC and RT-834/GRC, transmitter IF and audio module 1A5, schematic diagram.

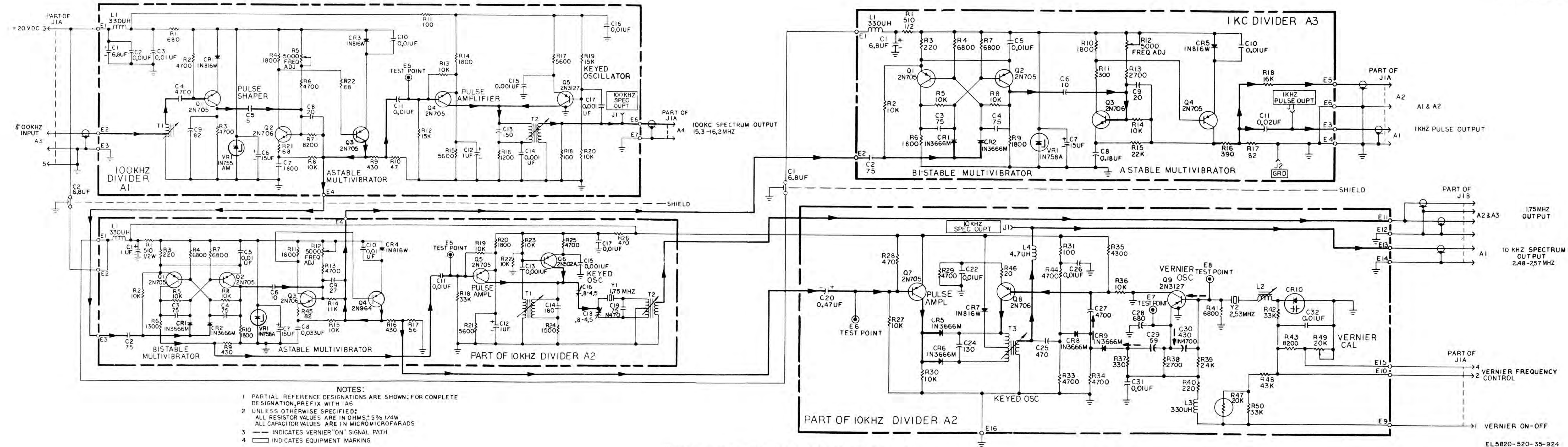
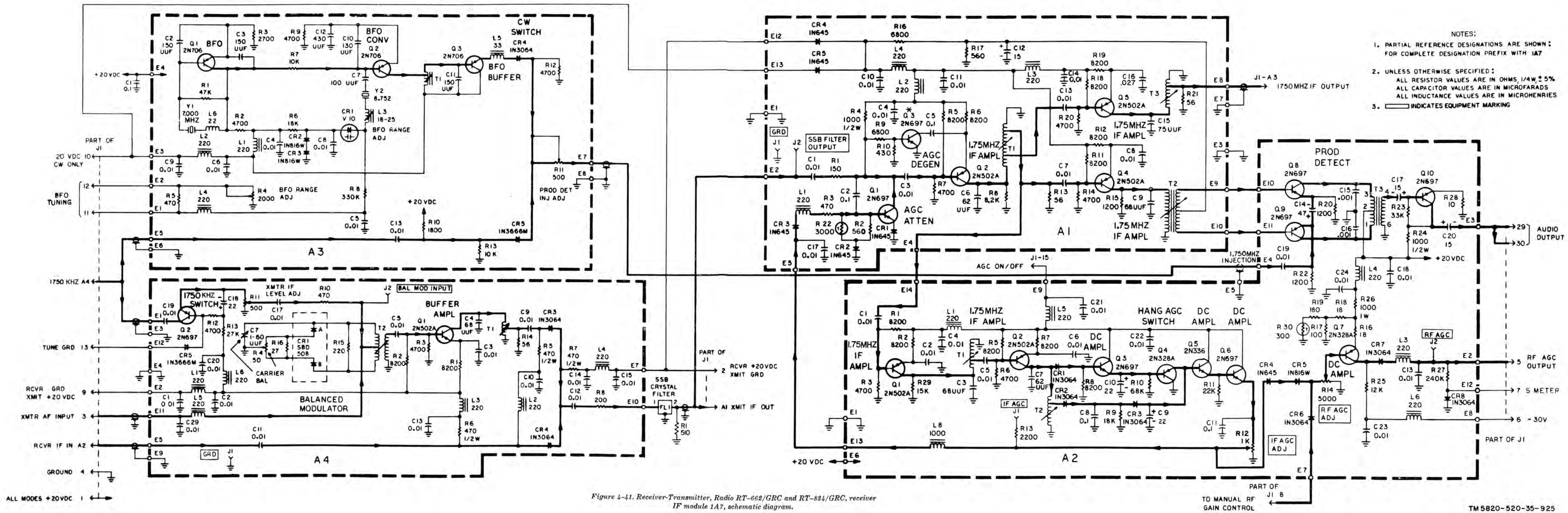

Figure 4-40. Receiver-Transmitter, Radio RT-662/GRC and RT-834/GRC, frequency divider module 1A6, schematic diagram.



- NOTES:
1. PARTIAL REFERENCE DESIGNATIONS ARE SHOWN; FOR COMPLETE DESIGNATION PREFIX WITH 1A7
 2. UNLESS OTHERWISE SPECIFIED:
ALL RESISTOR VALUES ARE IN OHMS, 1/4W, ± 5%
ALL CAPACITOR VALUES ARE IN MICROFARADS
ALL INDUCTANCE VALUES ARE IN MICROHENRIES
 3. INDICATES EQUIPMENT MARKING

Figure 4-41. Receiver-Transmitter, Radio RT-662/GRC and RT-884/GRC, receiver IF module 1A7, schematic diagram.

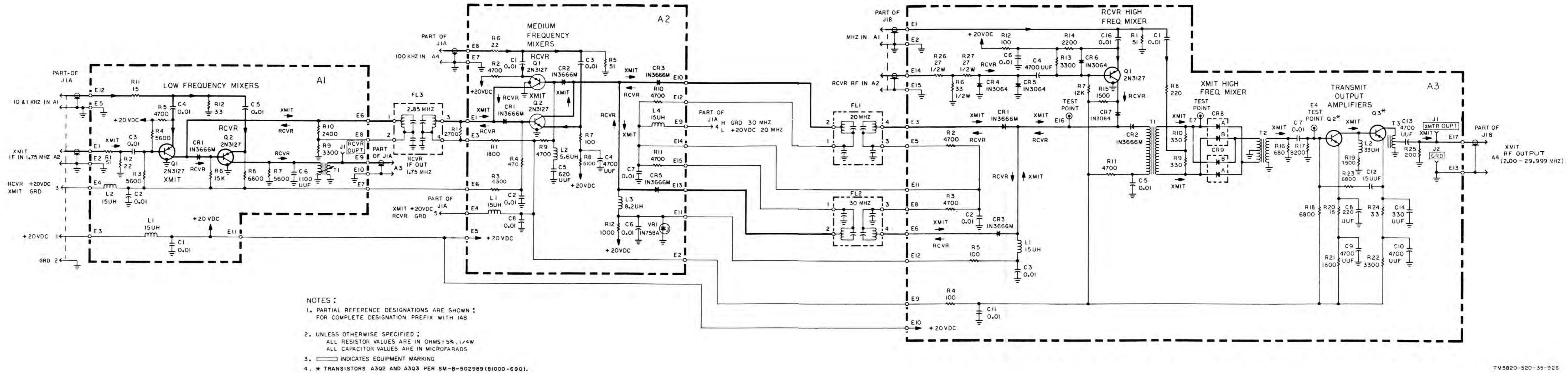

Figure 4-42. Receiver-Transmitter, Radio RT-662/GRC and RT-834/GRC, translator module 1A8, schematic diagram.

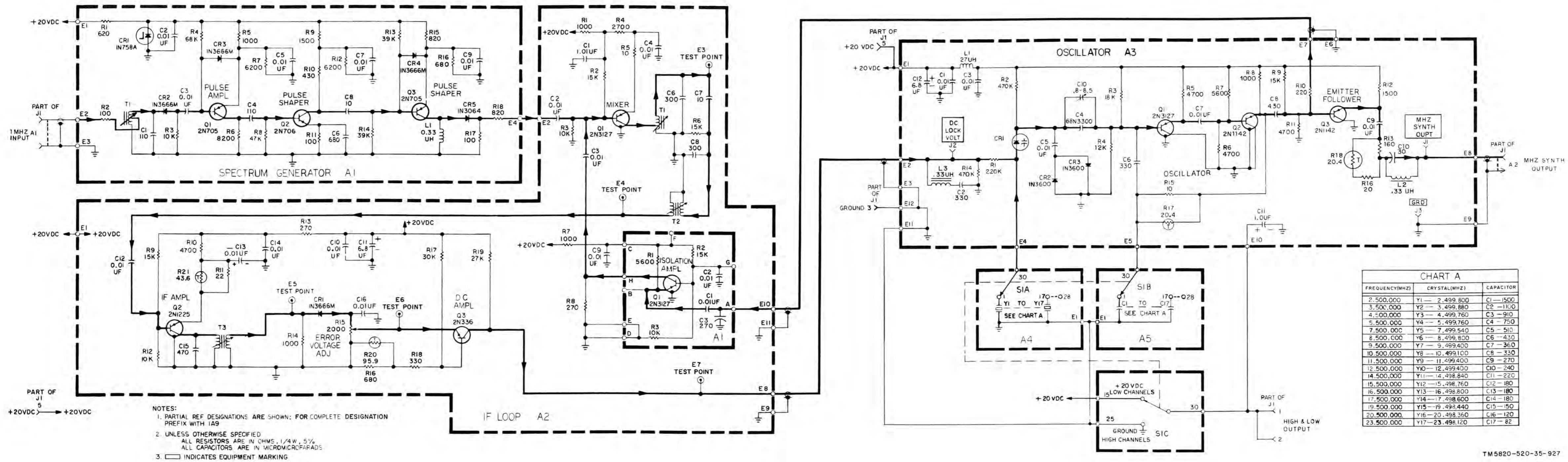

Figure 4-43. Receiver-Transmitter, Radio RT-662/GRC and RT-834/GRC, MHz synthesizer modulator 1A9, schematic diagram.

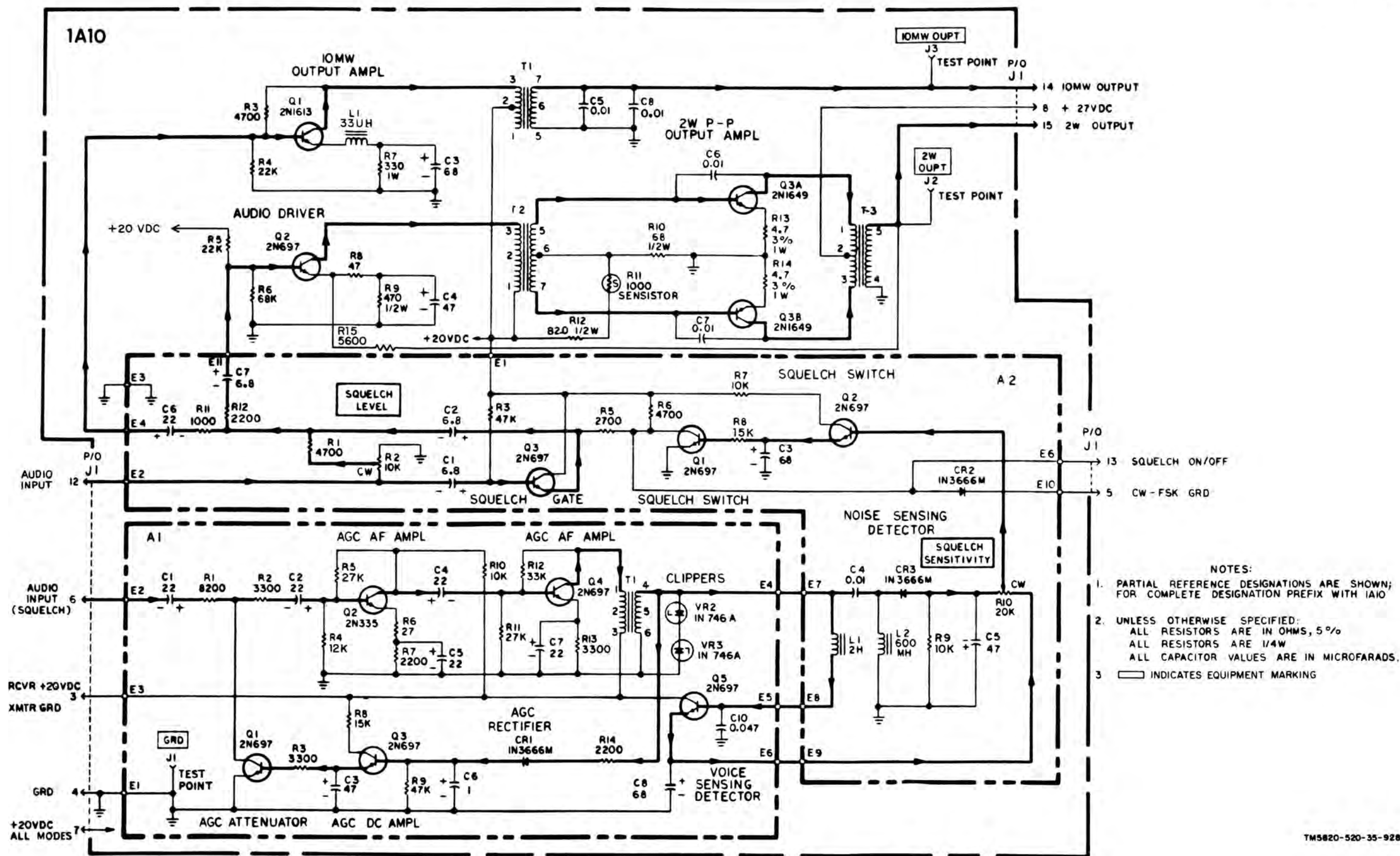

Figure 4-44. Receiver-Transmitter, Radio RT-662/GRC and RT-834/GRC, receiver audio module 1A10, schematic diagram.

TM5820-520-35-928

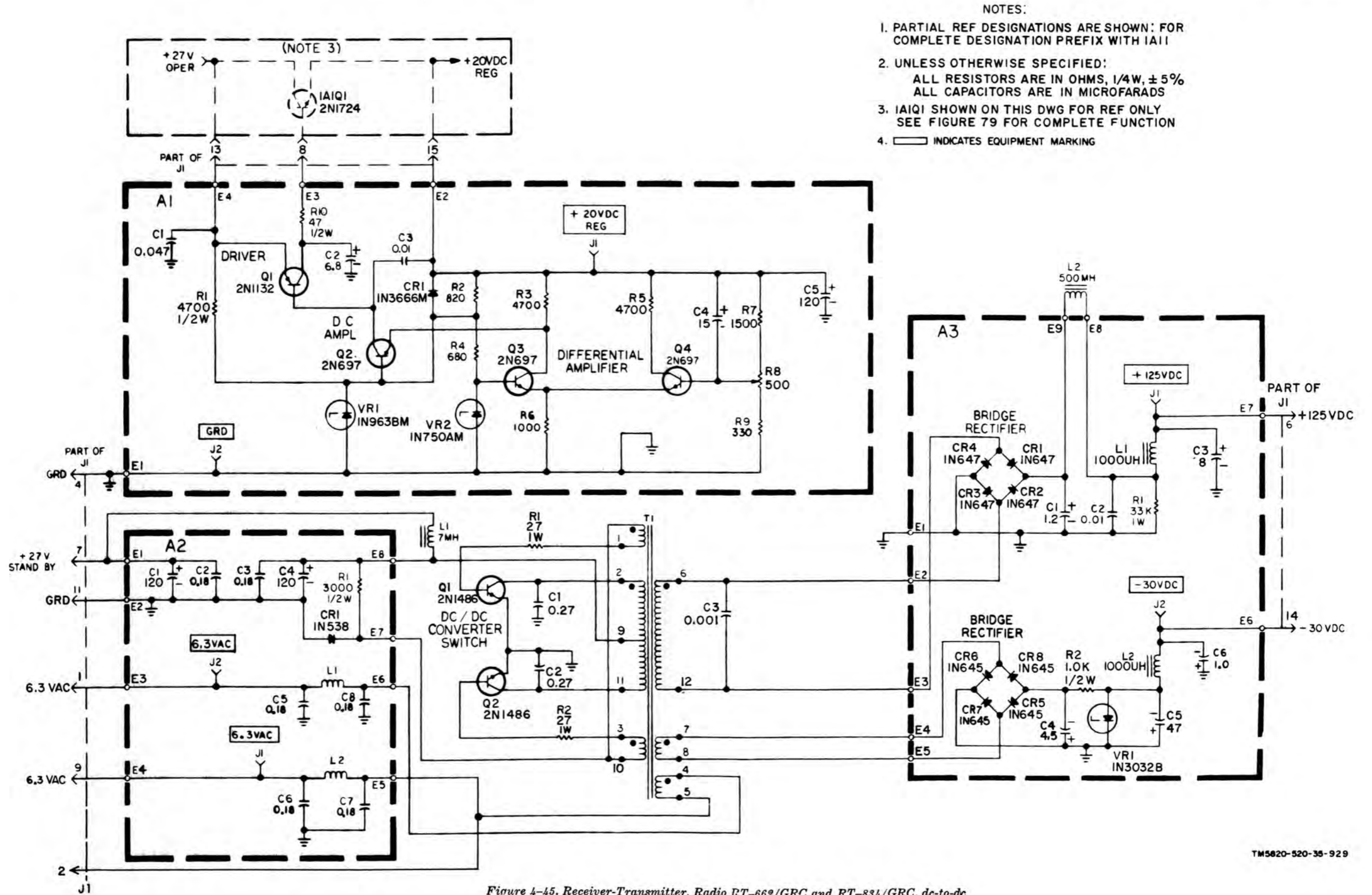
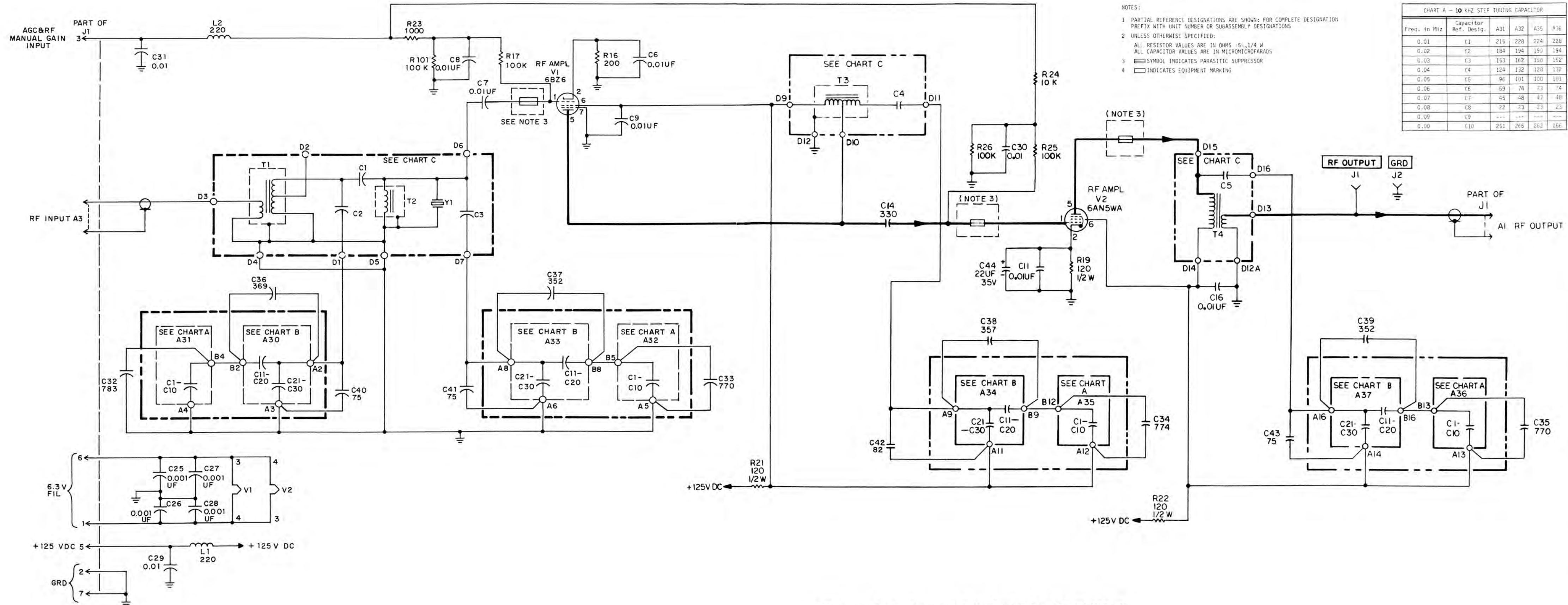

Figure 4-45. Receiver-Transmitter, Radio RT-662/GRC and RT-834/GRC, dc-to-dc converter and regulator module 1A11, schematic diagram.



- NOTES:
1. PARTIAL REFERENCE DESIGNATIONS ARE SHOWN. FOR COMPLETE DESIGNATION PREFIX WITH UNIT NUMBER OR SUBASSEMBLY DESIGNATIONS.
 2. UNLESS OTHERWISE SPECIFIED: ALL RESISTOR VALUES ARE IN OHMS (5, 1/4 W); ALL CAPACITOR VALUES ARE IN MICROMICROFARADS.
 3. SYMBOL INDICATES PARASITIC SUPPRESSOR.
 4. INDICATES EQUIPMENT MARKING.

CHART A - 10 KHZ STEP TUNING CAPACITOR

Freq. in MHz	Capacitor Ref. Design.	A31	A32	A35	A36
0.01	C1	215	228	224	228
0.02	C2	184	194	191	194
0.03	C3	153	162	158	152
0.04	C4	124	132	128	132
0.05	C5	96	101	100	101
0.06	C6	69	74	73	74
0.07	C7	45	48	47	48
0.08	C8	22	23	23	23
0.09	C9	---	---	---	---
0.00	C10	251	266	262	266

CHART B - 100 KHZ STEP TUNING CAPACITOR

Freq. in MHz	Capacitor Ref. Design.	A30	A33	A34	A37
0.10	C11	426	395	404	395
	C21	147	152	150	152
0.20	C12	332	309	316	309
	C22	118	122	121	122
0.30	C13	257	239	244	239
	C23	93	96	95	96
0.40	C14	195	182	185	182
	C24	72	74	73	74
0.50	C15	143	133	136	133
	C25	54	55	55	55
0.60	C16	99	92	94	92
	C26	37	38	38	38
0.70	C17	61	57	58	57
	C27	23	24	24	24
0.80	C18	29	26	27	26
	C28	11	11	11	11
0.90	C19	---	---	---	---
	C29	---	---	---	---
0.00	C20	545	504	517	504
	C30	181	187	185	187

CHART C - 100 KHZ STEP TUNING CAPACITOR

Freq. in MHz	On Assy	C1	On Assy	C2	On Assy	C3	On Assy	C4	On Assy	C5	On Assy	Y1
2	A16	9.1	A16	5HT	A16	5HT	A23	5HT	A2	5HT	A16	None
3	A17	6.2	A17	1247	A17	1255	A24	1253	A3	1255	A17	
4	A18	5.0	A18	623	A18	632	A25	623	A4	632	A18	
5	A19	5.1	A19	416	A19	424	A26	416	A5	424		
6	A20	3.9	A20	312	A20	320	A27	318	A6	320		
7	A21	3.3	A21	250	A21	258	A28	250	A7	258		
8	A22	3.0	A22	208	A22	217	A29	208	A8	217		
9	A23	2.7	A23	179	A23	187	A2	182	A9	187		
10	A24	2.7	A24	157	A24	165	A3	160	A10	165		
11	A25	2.4	A25	140	A25	148	A4	146	A11	148		
12	A26	2.2	A26	126	A26	134	A5	128	A12	134		
13	A27	2.0	A27	115	A27	123	A6	117	A13	123		
14	A28	2.0	A28	105	A28	113	A7	111	A14	113		
15	A29	2.0	A29	97	A29	105	A8	103	A15	105	A29	
16	A2	2.0	A2	91	A2	98	A9	96	A16	98	A2	
17	A3	2.0	A3	85	A3	92	A10	90	A17	92	A3	
18	A4	1.8	A4	80	A4	87	A11	85	A18	87	A4	None
19	A5	1.8	A5	75	A5	82	A12	80	A19	82	A5	21,000
20	A6	1.8	A6	71	A6	78	A13	76	A20	78	A6	19,000
21	A7	2.0	A7	67	A7	75	A14	73	A21	75		None
22	A8	2.0	A8	64	A8	71	A15	68	A22	71		
23	A9	2.0	A9	61	A9	68	A16	66	A23	68		
24	A10	2.0	A10	58	A10	66	A17	63	A24	66		
25	A11	2.0	A11	56	A11	63	A18	61	A25	63		
26	A12	2.0	A12	54	A12	61	A19	59	A26	61		
27	A13	2.0	A13	52	A13	58	A20	57	A27	58		
28	A14	2.0	A14	50	A14	56	A21	55	A28	56	A14	None
29	A15	2.0	A15	48	A15	55	A22	53	A29	55	A15	28,500

Figure 4-46. Receiver-Transmitter, Radio RT-662/GRC, and RT-834/GRC, rf amplifier module 1A12, schematic diagram.

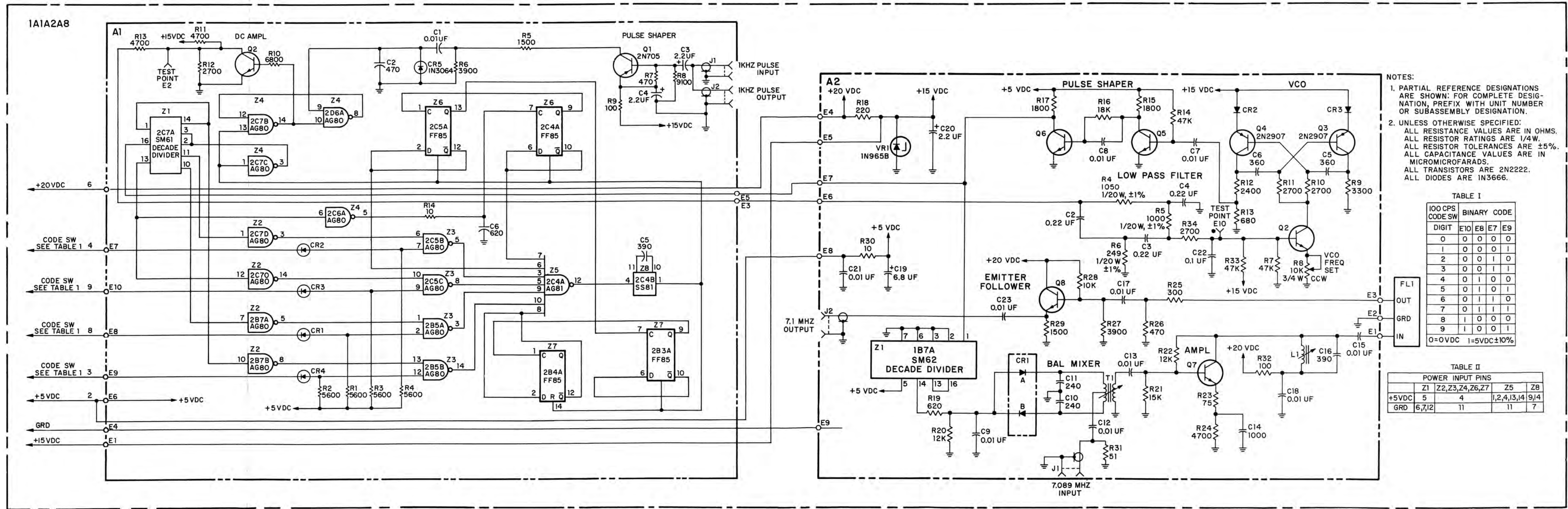

- NOTES:
- PARTIAL REFERENCE DESIGNATIONS ARE SHOWN; FOR COMPLETE DESIGNATION, PREFIX WITH UNIT NUMBER OR SUBASSEMBLY DESIGNATION.
 - UNLESS OTHERWISE SPECIFIED: ALL RESISTANCE VALUES ARE IN OHMS. ALL RESISTOR RATINGS ARE 1/4W. ALL RESISTOR TOLERANCES ARE ±5%. ALL CAPACITANCE VALUES ARE IN MICROMICROFARADS. ALL TRANSISTORS ARE 2N2222. ALL DIODES ARE IN3666.

TABLE I

100 CPS CODE SW	BINARY CODE			
DIGIT	E10	E8	E7	E9
0	0	0	0	0
1	0	0	0	1
2	0	0	1	0
3	0	0	1	1
4	0	1	0	0
5	0	1	0	1
6	0	1	1	0
7	0	1	1	1
8	1	0	0	0
9	1	0	0	1

0=0VDC 1=5VDC±10%

TABLE II

POWER INPUT PINS				
	Z1	Z2,Z3,Z4,Z6,Z7	Z5	Z8
+5VDC	5	4	1,2,4,13,14	9,14
GRD	6,7,12	11	11	7

Figure 4-47. Receiver-Transmitter, Radio RT-884/GRC, 100 Hz Module 1A1A2A8, schematic diagram.

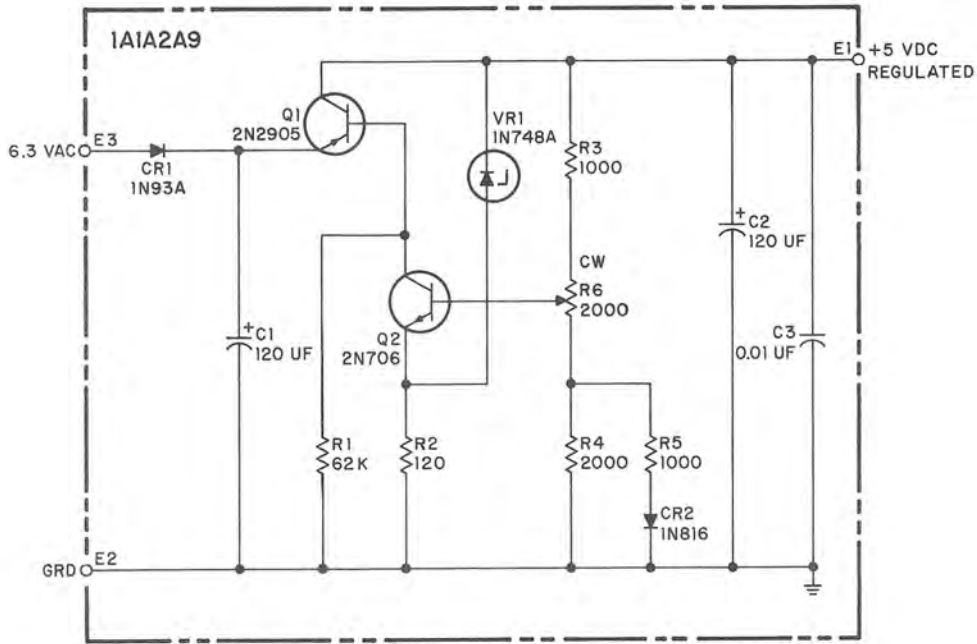

NOTES:

1. PARTIAL REFERENCE DESIGNATIONS ARE SHOWN. FOR COMPLETE DESIGNATIONS, PREFIX WITH UNIT NUMBER OR SUBASSEMBLY DESIGNATION.
2. UNLESS OTHERWISE SPECIFIED:
 ALL RESISTANCE VALUES ARE IN OHMS.
 ALL RESISTOR TOLERANCES ARE $\pm 5\%$.
 ALL RESISTOR RATINGS ARE 1/4W.

TM5820-520-35-932

Figure 4-48. Receiver-Transmitter, Radio RT-834/GRC, filament regulator 1A1A2A9, schematic diagram.

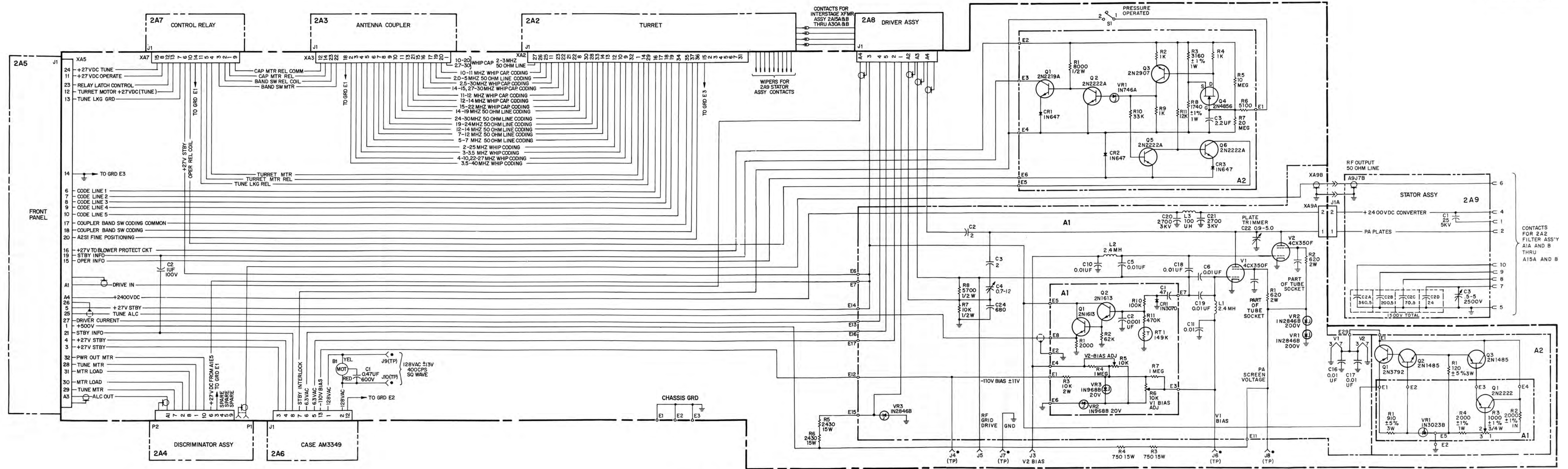
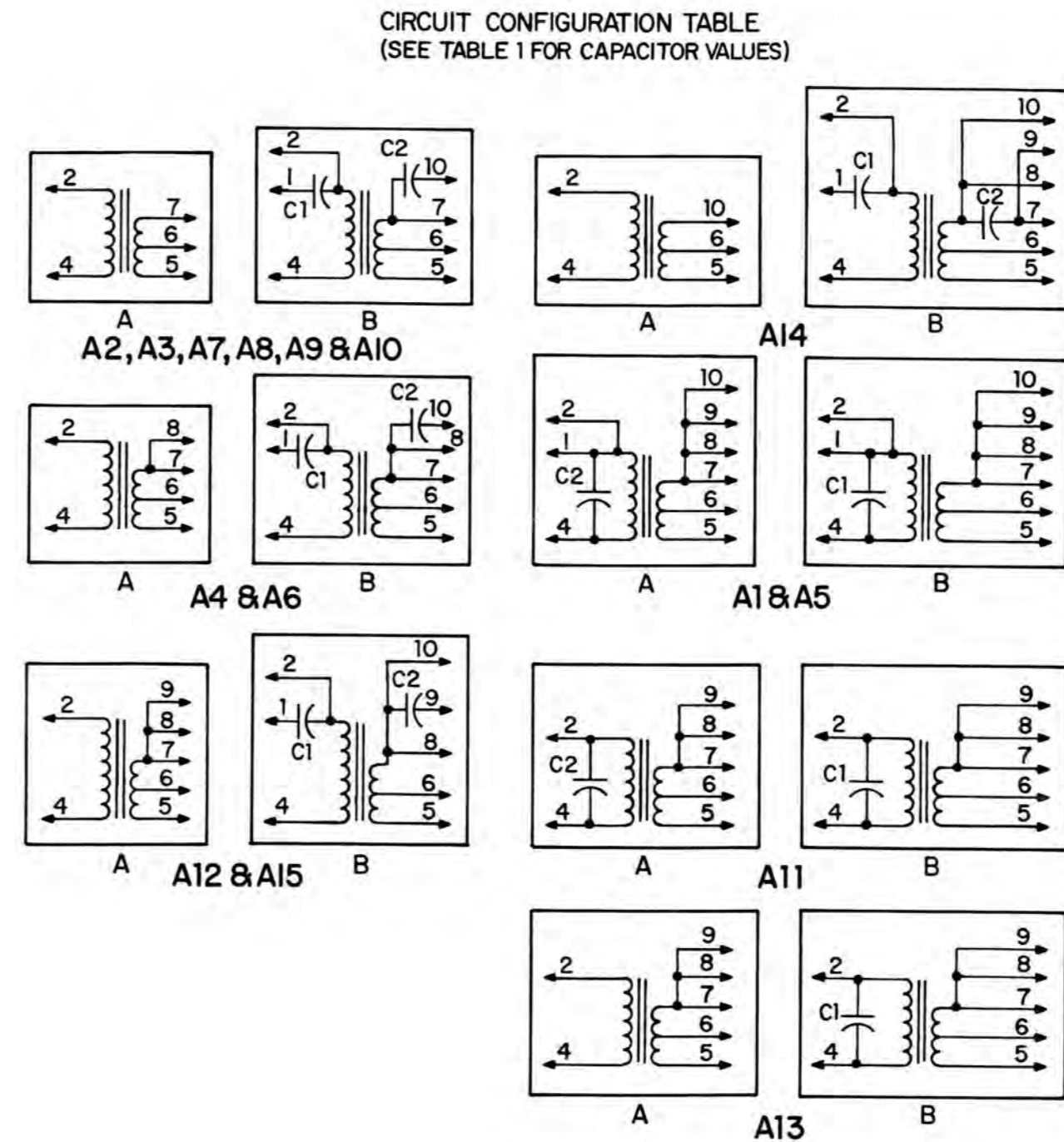
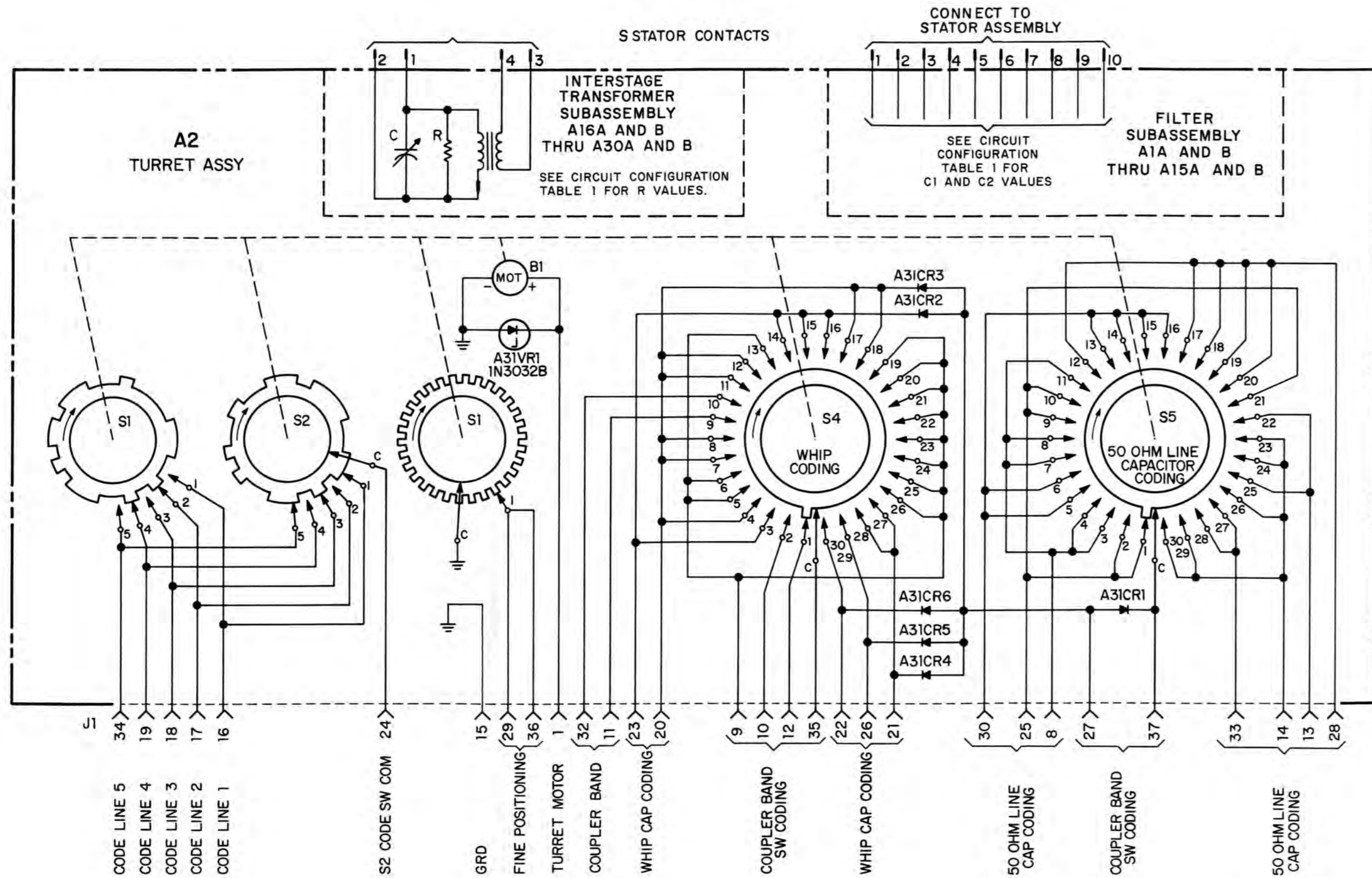
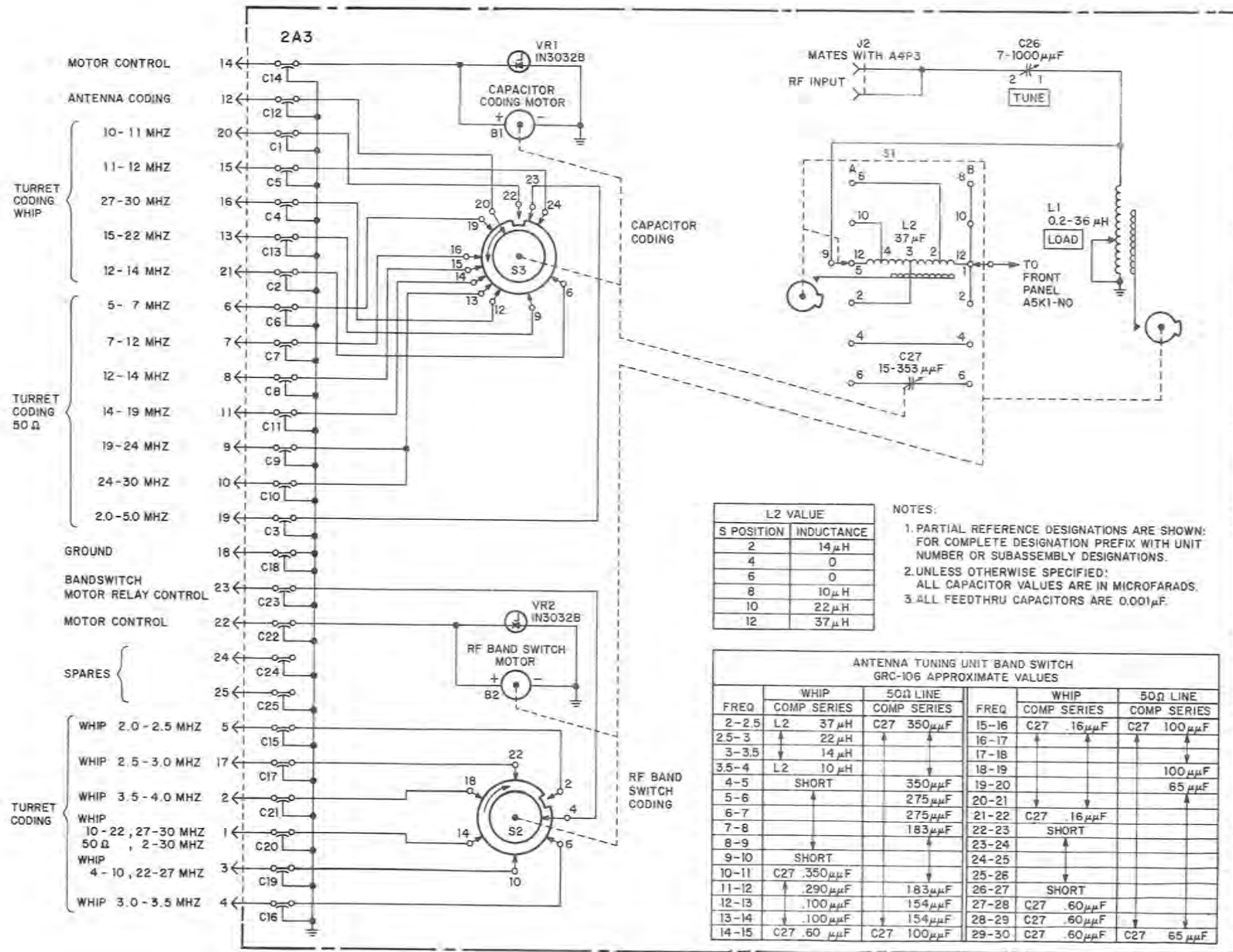

Figure 4-49. Amplifier-Radio Frequency, AM-3349/GRC-106, chassis assembly 2A1, and blower protection 2A1A2, and filament regulator 2A1A1A2 tune APC 2A1A1A1, schematic diagram.



POS	TURRET FREQ MHZ	CODE					FILTERS		INTSTG XFMR		
		1	2	3	4	5	A No.	C1	C2	A No.	R VALUE
1	2.0 - 2.5	0	1	0	1	0	A1B	13-5		A19B	1600
2	3.0 - 3.5	0	1	0	1	1	A1A		13-5	A19A	2000
3	14 - 15	1	0	0	1	0	A2B	11.95-5		A20B	2400
4	15 - 16	1	1	0	0	1	A2A			A20A	2400
5	24 - 25	0	1	1	0	0	A3B	7.7-5	12.4-3	A21B	2200
6	25 - 26	0	0	1	1	0	A3A			A21A	2400
7	16 - 17	0	0	0	1	1	A4B	9.5-5	27.85-3	A22B	2200
8	17 - 18	1	0	0	0	1	A4A			A22A	2200
9	2.5 - 3	0	1	0	0	0	A5B	13-5		A23B	1800
10	3.5 - 4	0	0	1	0	0	A5A		13-5	A23A	2000
11	18 - 19	0	0	0	1	0	A6B	8.5-5	23.93	A24B	2200
12	19 - 20	0	0	0	0	1	A6A			A24A	2200
13	26 - 27	1	0	0	0	0	A7B	6.6-5	13.15-3	A25B	2400
14	27 - 28	1	1	0	0	0	A7A			A25A	2700
15	28 - 29	1	1	1	0	0	A8B	5.8-5	13.2-3	A26B	3000
16	29 - 30	1	1	1	1	0	A8A			A26A	3600
17	20 - 21	0	1	1	1	1	A9B	8.2-5	15.0-3	A27B	2200
18	21 - 22	1	0	1	1	1	A9A			A27A	2200
19	22 - 23	1	1	0	1	1	A10B	8.2-5	13.3-3	A28B	2200
20	23 - 24	0	1	1	0	1	A10A			A28A	2200
21	4 - 5	1	0	1	1	0	A11B	2-5		A29B	2700
22	5 - 6	0	1	0	1	1	A11A		2-5	A29A	3000
23	8 - 9	1	0	1	0	1	A12B	22.9-5	14.0-3	A30B	3000
24	9 - 10	1	1	0	1	0	A12A			A30A	3000
25	6 - 7	1	1	1	0	1	A13B	2.0-5		A16B	3000
26	7 - 8	0	1	1	1	0	A13A			A16A	3000
27	12 - 13	0	0	1	1	1	A14B	12.9-5	21.0-3	A17B	2700
28	13 - 14	1	0	0	1	1	A14A			A17A	2400
29	10 - 11	0	1	0	0	1	A15B	16.5-5	17.7-3	A18B	3000
30	11 - 12	1	0	1	0	0	A15A			A18A	3000

Figure 4-50. Amplifier Radio, Frequency AM-3349/GRC-106, turret assembly A2, schematic diagram.



L2 VALUE	
S POSITION	INDUCTANCE
2	14 μ H
4	0
6	0
8	10 μ H
10	22 μ H
12	37 μ H

- NOTES:
1. PARTIAL REFERENCE DESIGNATIONS ARE SHOWN: FOR COMPLETE DESIGNATION PREFIX WITH UNIT NUMBER OR SUBASSEMBLY DESIGNATIONS.
 2. UNLESS OTHERWISE SPECIFIED: ALL CAPACITOR VALUES ARE IN MICROFARADS.
 3. ALL FEEDTHRU CAPACITORS ARE 0.001 μ F.

ANTENNA TUNING UNIT BAND SWITCH GRC-106 APPROXIMATE VALUES									
FREQ	WHIP		50 Ω LINE		FREQ	WHIP		50 Ω LINE	
	COMP SERIES	INDUCTANCE	COMP SERIES	INDUCTANCE		COMP SERIES	INDUCTANCE	COMP SERIES	INDUCTANCE
2-2.5	L2	37 μ H	C27	350 μ F	15-16	C27	.16 μ F	C27	100 μ F
2.5-3		22 μ H			16-17				
3-3.5		14 μ H			17-18				
3.5-4	L2	10 μ H			18-19				100 μ F
4-5	SHORT			350 μ F	19-20				65 μ F
5-6				275 μ F	20-21				
6-7				275 μ F	21-22	C27	.16 μ F		
7-8				183 μ F	22-23	SHORT			
8-9					23-24				
9-10	SHORT				24-25				
10-11	C27	350 μ F			25-26				
11-12		290 μ F		183 μ F	26-27	SHORT			
12-13		100 μ F		154 μ F	27-28	C27	.60 μ F		
13-14		.100 μ F		154 μ F	28-29	C27	.60 μ F		
14-15	C27	.60 μ F	C27	100 μ F	29-30	C27	.60 μ F	C27	65 μ F

TM5820-520-35-935

Figure 4-51. Amplifier-Radio, Frequency AM-3349/GRC-106, antenna coupler 2A3, schematic diagram.

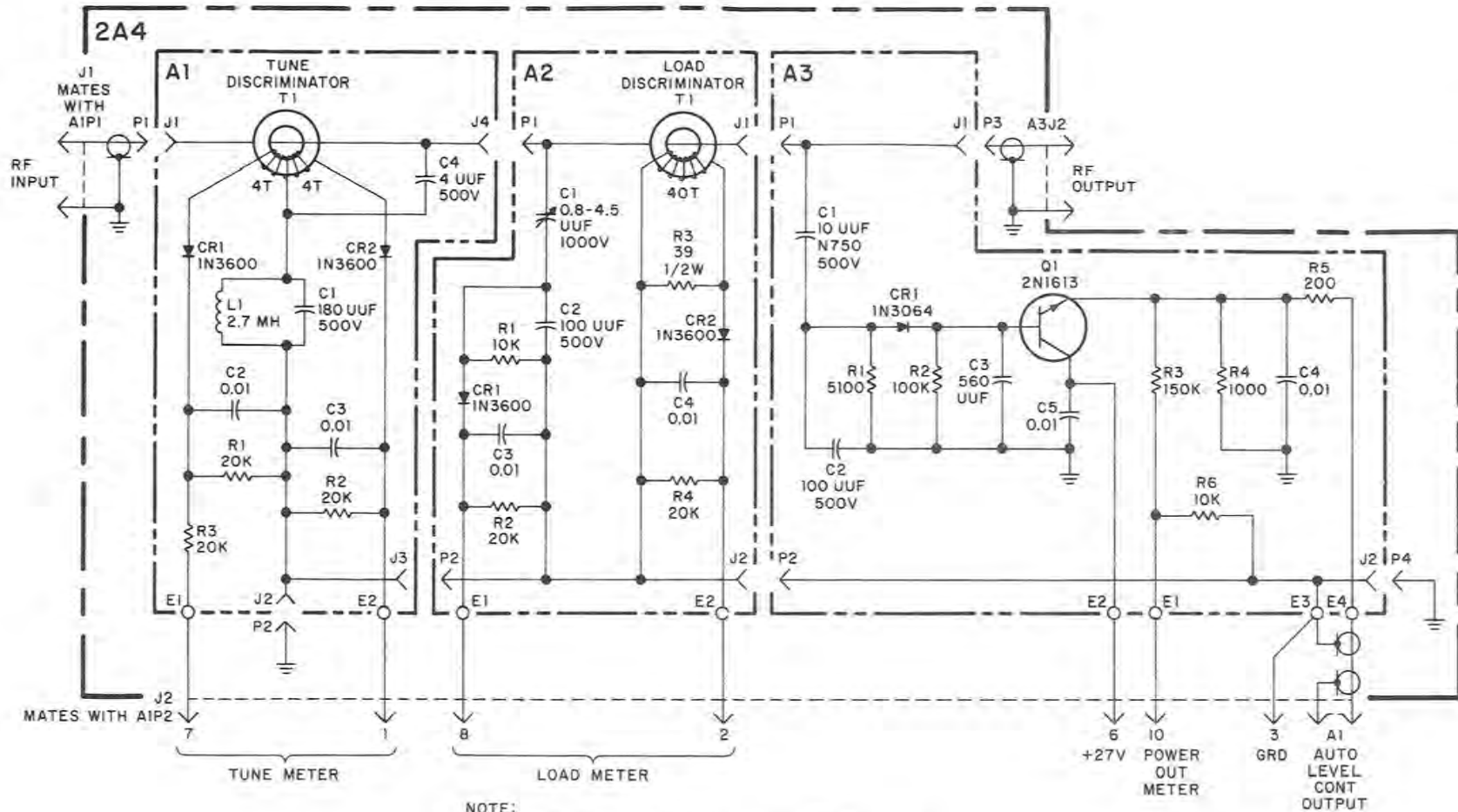

NOTE:

1. PARTIAL REFERENCE DESIGNATIONS ARE SHOWN: FOR COMPLETE DESIGNATION, PREFIX WITH UNIT NUMBER OR SUBASSEMBLY DESIGNATIONS.
2. UNLESS OTHERWISE SPECIFIED: ALL RESISTOR VALUES ARE IN OHMS $\pm 5\%$ 1/4W. ALL CAPACITOR VALUES ARE IN MICROFARADS, 200V.

TM5820-520-35-936

Figure 4-52. Amplifier-Radio, Frequency AM-3349/GRC-106, discriminator assembly 2A4, schematic diagram.

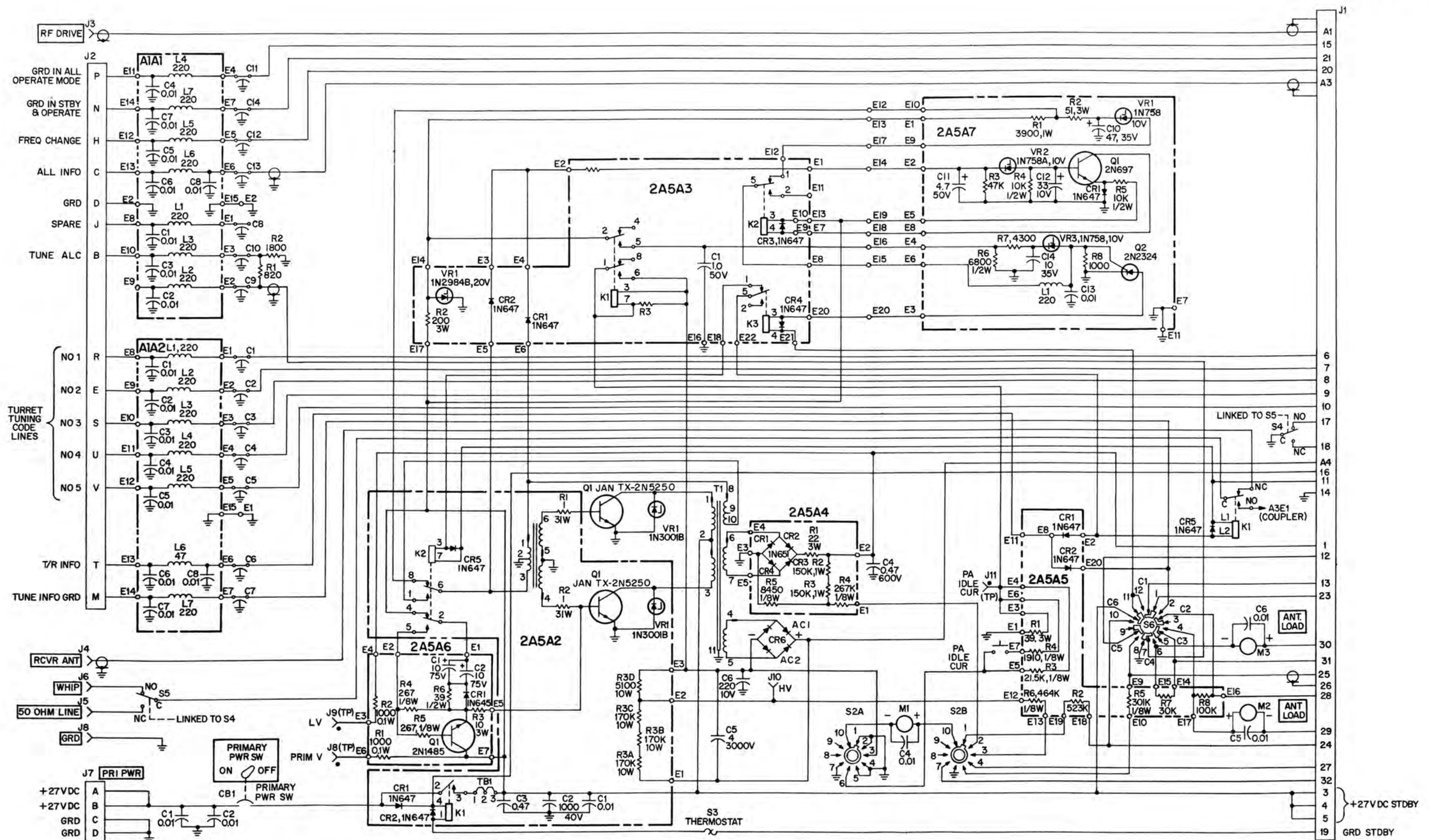
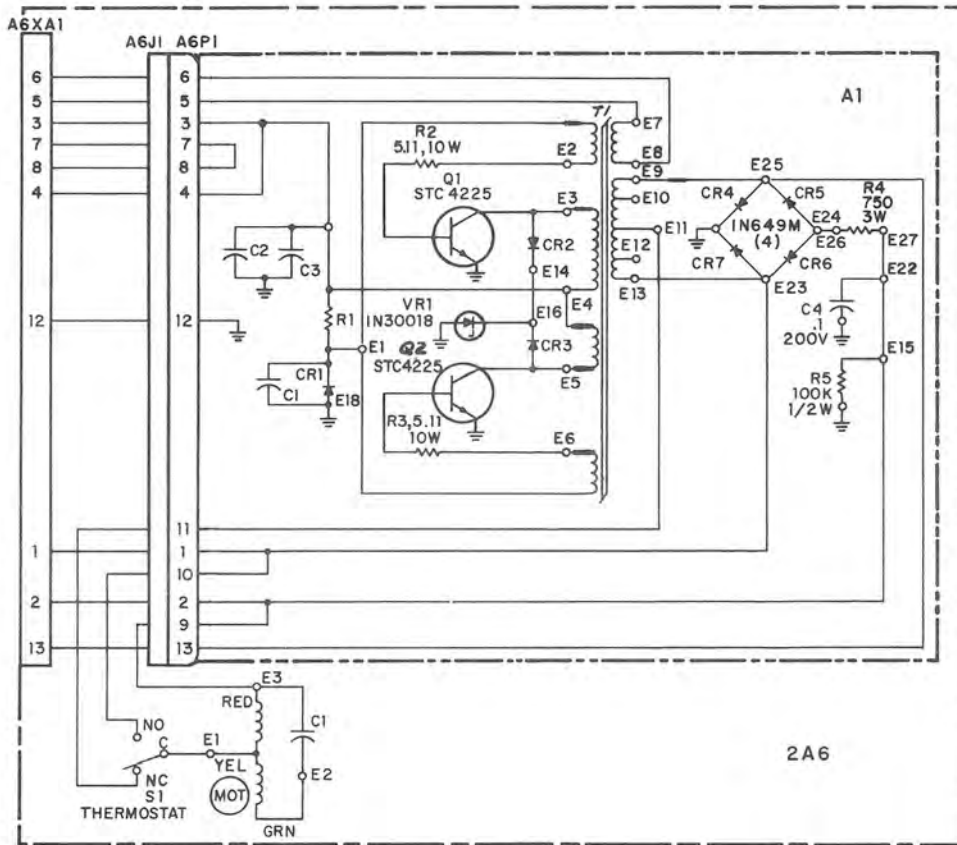

Figure 4-53. Amplifier-Radio, Frequency AM-3349/GRC-106, front panel 2A5, schematic diagram.



TM5820-520-35-938

Figure 4-54. Amplifier-Radio Frequency AM-3349/GRC-106, case assembly 2A6, schematic diagram.

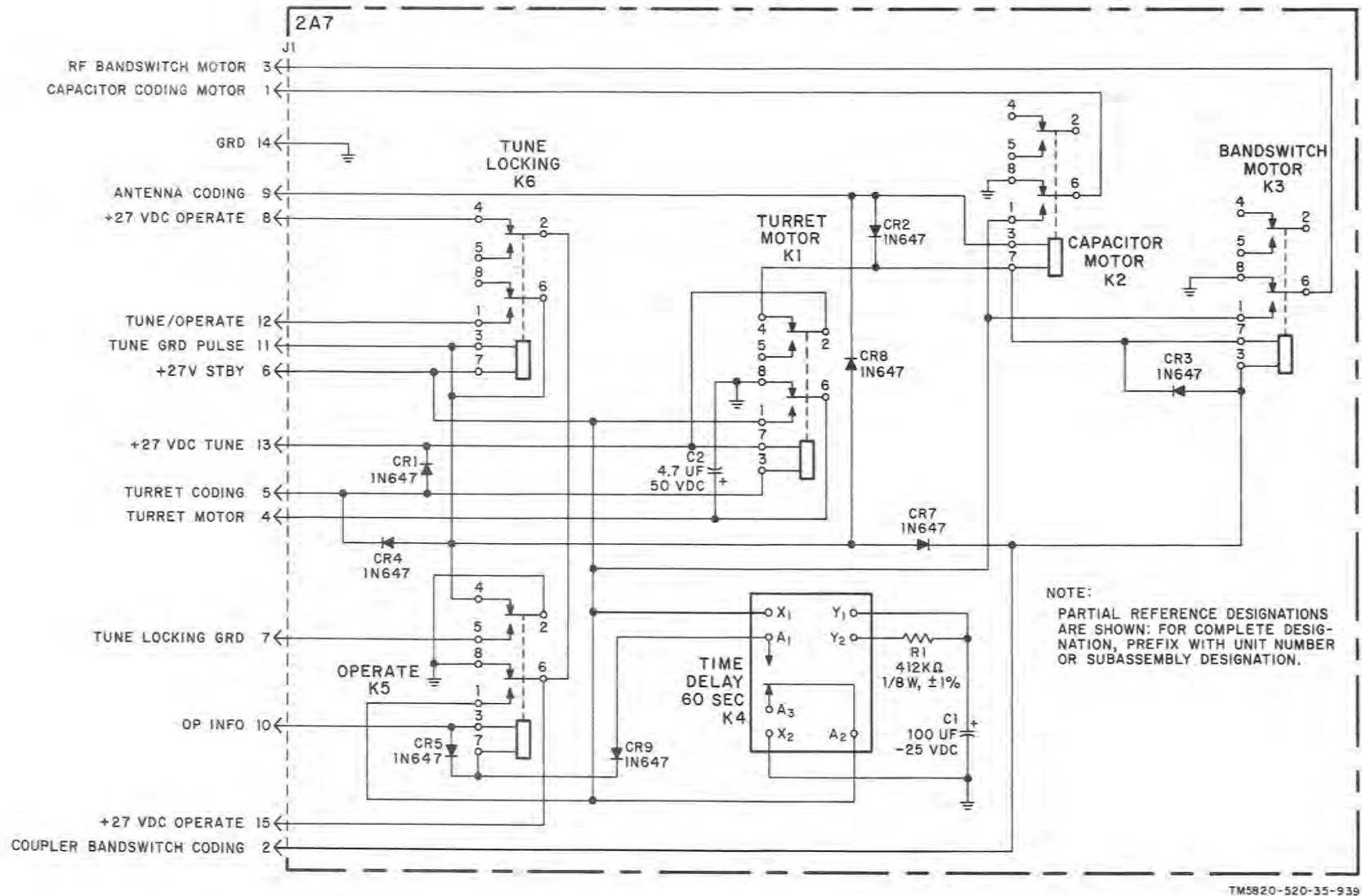
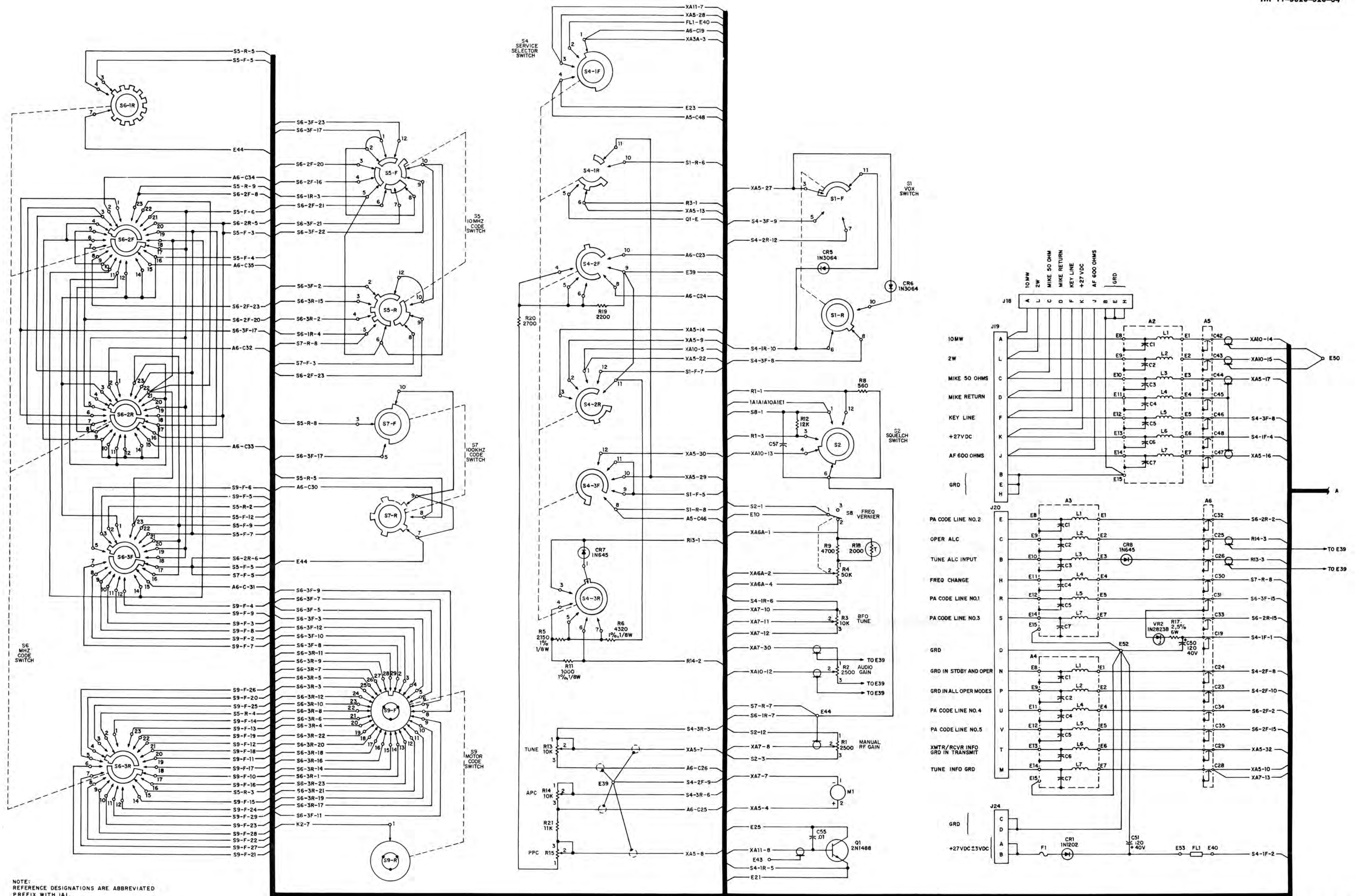

Figure 4-55. Amplifier-Radio Frequency AM-3349/GRC-106, relay assembly 2A7, schematic diagram.



NOTE: REFERENCE DESIGNATIONS ARE ABBREVIATED PREFIX WITH IA1.

Figure 4-56(1). Radio Set AN/GRC-106(*), RT-662/GRC or RT-834/GRC, interconnecting diagram (sheet 1 of 2).

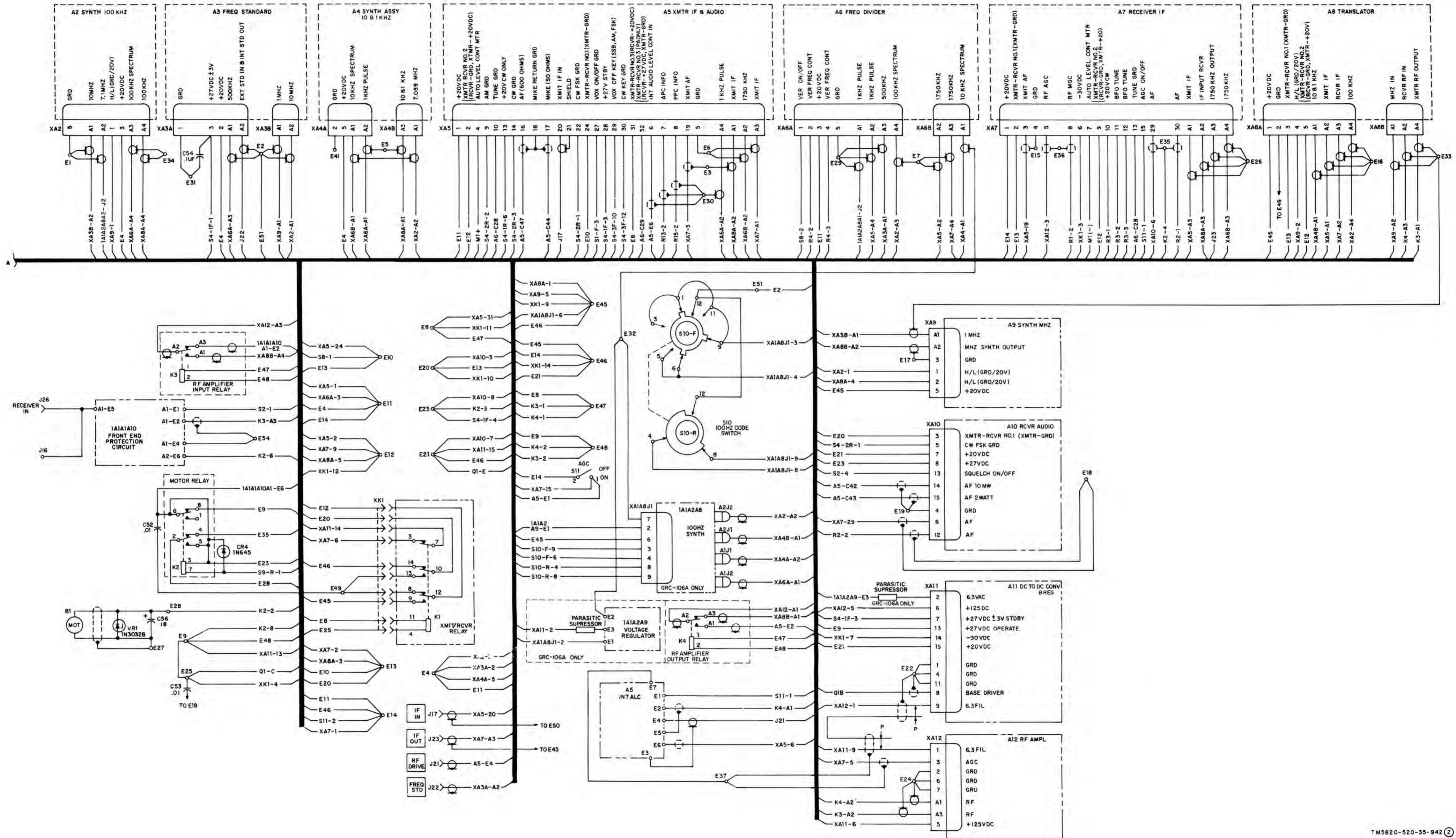

Figure 4-56(2). Radio Set AN/GRC-106(*), RT-662/GRC or RT-834/GRC interconnecting diagram (sheet 2 of 2).

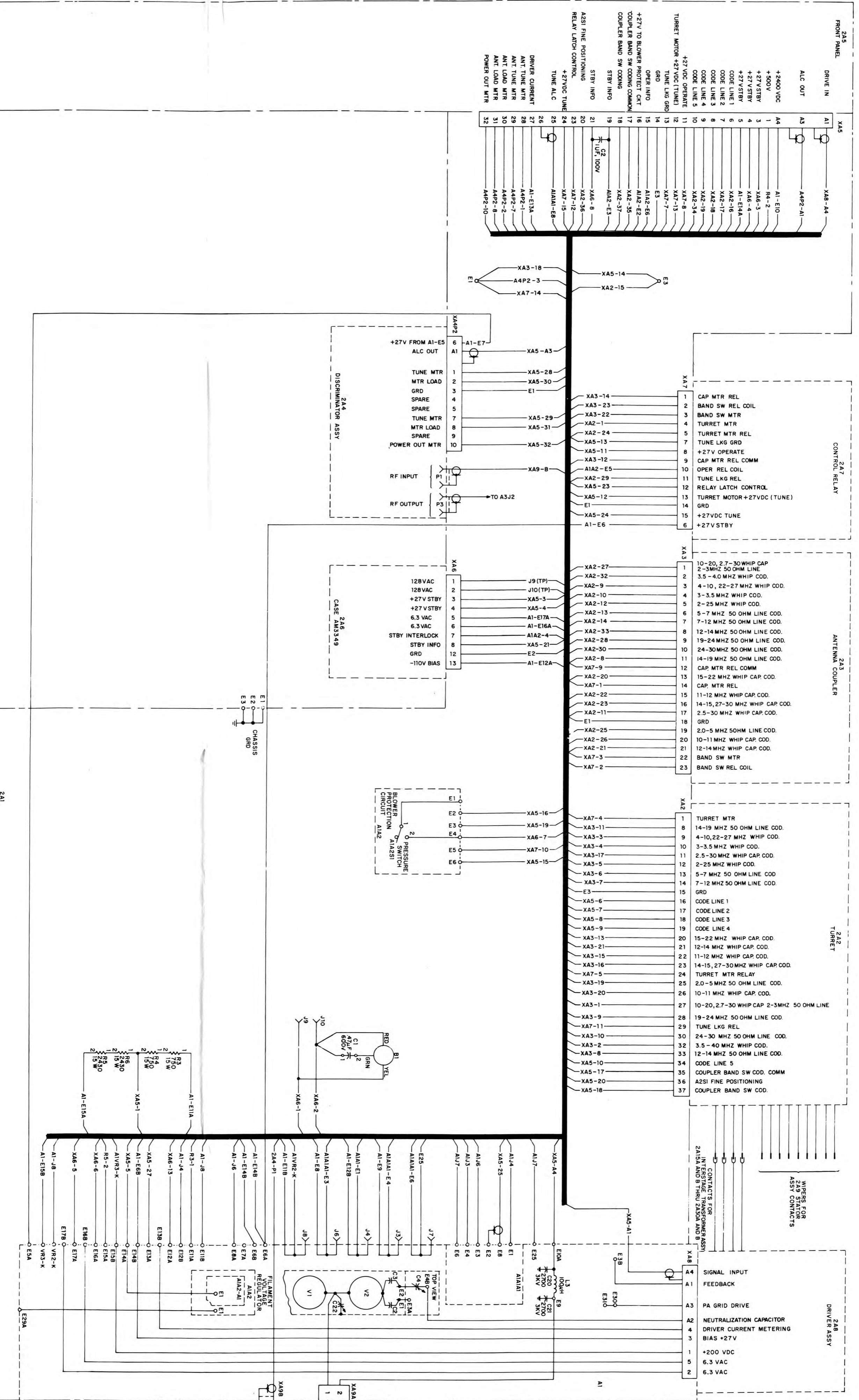

Figure 4-57(2), Radio Set AN/GRC-106(*), AM-3349/GRC-106 interconnecting diagram (sheet 2 of 2).

APPENDIX A

REFERENCES

Following is a list of publications available to the repairman of Radio Set AN/GRC-106(*):

DA Pam 310-4	Index of Technical Manuals, Technical Bulletins, Supply Manuals (types 7, 8, and 9), Supply Bulletins, and Lubrication Orders.
DA Pam 310-7	US Army Equipment Index of Modification Work Orders.
TB SIG 291	Safety Measures to be Observed When Installing and Using Whip Antennas, Field Type Masts, Towers, Antennas, and Metal Poles That Are Used With Communication, Radar, and Direction Finder Equipment.
TM 11-5097	Spectrum Analyzers TS-723A/U, TS-723B/U, TS-723C/U, and TS-723D/U.
TM 11-5820-467-15	Operator, Organizational, Field and Depot Maintenance Manual: Antenna Group AN/GRA-50.
TM 11-5820-467-25P	Organizational, DS, GS, and Depot Maintenance Repair Parts and Special Tool Lists: Antenna Group AN/GRA-50.
TM 11-5820-520-12	Operator's and Organizational Maintenance Manual Radio Sets AN/GRC-106 and AN/GRC-106A.
TM 11-5820-765-12	Operator's and Organizational Maintenance Manual Power Supplies PP-4763/GRC and PP-4763A/GRC.
TM 11-5965-202-35	Field and Depot Maintenance: Handsets H-33D/PT, H-33E/PT, and H-33F/PT.
TM 11-5965-222-15P	Operator, Organizational, Field and Depot Maintenance Repair Parts and Special Tool Lists and Maintenance Allocation Chart: Dynamic Loudspeaker LS-166/U.
TM 11-5965-260-15P	Operator, Organizational, Field and Depot Maintenance Repair Parts and Special Tool Lists: Headset Electrical H-140A/U.
TM 11-6625-200-15	Operator, Organizational, DS, GS, and Depot Maintenance Manual: Multimeters ME-26A/U, ME-26B/U, ME-26C/U, and ME-26D/U.
TM 11-6625-203-12	Operator and Organizational Maintenance: Multimeter AN/URM-105, Including Multimeter ME-77/U.
TM 11-6625-316-12	Operator and Organizational Maintenance Manual: Test Sets, Electron Tube TV-2/U, TV-2A/U, TV-2B/U, and TV-2C/U.
TM 11-6625-320-12	Operator and Organizational Maintenance Manual: Voltmeter, Meter ME-30A/U, and Voltmeters, Electronic ME-30B/U, ME-30C/U, and ME-30E/U.
TM 11-6625-366-15	Operator's, Organizational, DS, GS, and Depot Maintenance Manual: Multimeter TS-352B/U.
TM 11-6625-524-14	Operator, Organizational, and Field Maintenance Manual: Voltmeter, Electronic AN/URM-145.
TM 11-6625-539-15	Operator, Organizational, Field and Depot Maintenance Manual: Transistor Test Set TS-1836/U.
TM 11-6625-573-15	Operator, Organizational, DS, GS, and Depot Maintenance Manual: Signal Generator AN/GRM-50.
TM 11-6625-683-15	Operator, Organizational, Direct Support, General Support, and Depot Maintenance Manual: Signal Generator AN/URM-127.
TM 11-6625-700-10	Operator's Manual: Digital Readout, Electronic Counter AN/USM-207.

TM 11-5820-520-34

TM 11-6625-847-12

TM 11-6625-1703-15

TM 38-750

Organizational Maintenance Manual Including Repair Parts and Special Tools List: Simulator, Radio Frequency SM-442A/GRC.

Operator, Organizational, DS, GS, and Depot Maintenance Manual Including Repair Parts and Special Tool Lists: Oscilloscope AN/USM-281A.

The Army Maintenance Management System (TAMMS).

INDEX

	Paragraph	Page
Adjustments:		
Dc-to-Dc converter and regulator module 1A11	3-31	3-45
Discriminator assembly 2A4	3-35	3-48
Frequency dividers module 1A6	3-28	3-39
Frequency standard module 1A3	3-32	3-45
MHz synthesizer module 1A9	3-26	3-38
Neutralization capacitor	2-29	2-88
Receiver audio module 1A10	3-30	3-44
Receiver IF module 1A7	3-29	3-42
Transmitter IF and audio module 1A5	3-27	3-38
Voltage regulator assembly 1A1A2A9 (RT-834/GRC)	3-34	3-48
100 kHz synthesizer Module 1A2	3-24	3-34
100 Hz synthesizer Module	3-33	3-47
Antenna coupler assembly 2A3	1-32	1-55
Assembly removal for AM-3349/GRC-106	2-19	2-68
Assembly replacement for AM-3349/GRC-106	2-19	2-68
Assembly tests for AM-3349/GRC-106	4-6	4-34
Automatic level control	1-41	1-62
Automatic programing test	3-48	3-62
Capacitor programing	2-15	2-56
Chassis assembly and front panel	1-26	1-47
Cleaning	2-26	2-84
Dc-to-dc converter assembly (part of 2A5)	1-35	1-58
Dc-to-dc converter and regulator module 1A11	3-19	3-22
Dc-to-dc inverter assembly 2A6A1	1-34	1-57
Direct support adjustments	2-28	2-88
Direct support general instructions	2-4	2-4
Direct support inspection	2-25	2-83
Direct support lubrication	2-27	2-85
Disassembly of turret assembly 2A2	3-37d	3-50
Driver amplifier 2A8V1	1-30	1-52
Driver amplifier 2A8V1 feedback capacitor adjustment	3-46	3-59
Error cancellation	1-21	1-34
E-terminal voltage measurements	3-12	3-11
Filament regulator 2A1A2	3-22	3-25
Filter and stator assembly 2A9	2-15	2-56
Frequency dividers module 1A6	1-16, 3-15	1-24, 3-15
Frequency scheme	1-20	1-34
Frequency standard module	1-15, 3-10	1-22, 3-7
Frequency synthesis (RT-834/GRC)	1-22	1-37
Front end protection circuit 1A1A1A10	3-5	3-3
Front panel and chassis assembly 1A1	1-26	1-47
Functional description of receive operation	1-4	1-4
Functional description of transmit operation	1-3	1-1
Indexes of publications	1-1	1-1
Interconnecting cables	1-50	1-72
Internal ALC assembly 1A1A2A5	3-6	3-3
Keying circuits	1-48	1-69
Level control signal circuits	1-46	1-66
Load discriminator 2A4A2	1-40	1-61
Localizing troubles 2-9	2-13	2-37
Lubrication of AM-3349/GRC-106	3-41	3-54
Mechanical alignment of driver assembly 2A8	3-43	3-57

	Paragraph	Page
MHz Synthesizer module 1A9	1-18, 3-17	1-29, 3-19
Module and assembly removal (RT-662/GRC)	2-17	2-65
Module and assembly removal (RT-834/GRC)	2-18	2-68
Module and assembly replacement (RT-662/GRC)	2-17	2-65
Module and assembly replacement (RT-834/GRC)	2-18	2-68
Module performance tests	4-4	4-1
Module tests	3-50	3-64
Organization of troubleshooting procedures	2-5	2-4
Oven assembly 1A3A1	3-11	3-9
Overcurrent protection circuit	1-36	1-59
100 kHz synthesizer module 1A2	1-19	1-31
100 Hz synthesis localizing troubles	2-11	2-35
Parts replacement techniques	2-16	2-64
Plate trimmer capacitors adjustment	2-30	2-89
Power amplifiers 2A2A1V1 and 2A2A1V2	1-31	1-54
Power amplifiers neutralization	2-29	2-88
Power control circuits	1-47	1-67
Power output adjustment	3-47	3-60
Reassembly of turret assembly 2A2	3-37d	3-50
Receiver audio module 1A10	1-13	1-19
Receive:		
IF module 1A7	1-12	1-16
RF Amplifier module 1A12	1-10	1-14
Translator module 1A8	1-11	1-14
Operation, functional description	1-28	1-52
Removal of:		
Components of antenna coupler assembly 2A3	3-38	3-51
Parts for front panel assembly 2A5	2-20	2-80
Parts for chassis assembly 2A1	2-21	2-81
Blower assembly 2A6B1	2-22	2-82
Replacement of:		
Antenna coupler assembly 2A3	3-38	3-51
Blower assembly 2A6B1	2-22	2-82
Parts for chassis assembly 2A1	2-21	2-81
Driver amplifier tube 2A8V1	2-24	2-82
Parts for front panel assembly 2A5	2-20	2-80
Reporting of manual improvements	1-2	1-1
RT-834/GRC frequency synthesis	1-22	1-37
10 and 1 kHz synthesizer module 1A4	1-17, 3-13	1-27, 3-13
10 and 1 kHz synthesizer module 1A4 adjustment	3-25	3-36
Test equipment required for direct support	2-6	2-6
Test equipment for general support	3-2	3-1
Test meter 2A5M1	1-44	1-65
Test point information	2-7	2-6
Test setup for troubleshooting	2-8	2-10
Test setup for troubleshooting AM-3349/GRC-106	2-12	2-31
Tools required for installation	2-1	2-1
Transmit:		
Operation, functional description	1-27	1-51
RF amplifier module 1A12	1-8	1-13
Translator module 1A8	1-7	1-12
Transmitter IF and audio module 1A5	1-6, 3-14	1-6, 3-14
Tune automatic level control	1-42	1-63
Tune discriminator 2A4A1 (meter 2A5M2)	1-39	1-60
Tuning circuits	1-49	1-70
Tuning of antenna coupler assembly 2A3	1-43	1-63
Turret assembly 2A2	2-15	2-56
Typical interconnection	2-3	2-3
Typical installation	2-2	2-1
Undervoltage protection circuit	1-37	1-59
Voltage regulator 1A1A2A9	3-8	3-5
Voltage and resistance measurements	2-14	2-52

By Order of the Secretary of the Army:

W. C. WESTMORELAND,
General, United States Army,
Chief of Staff.

Official:

VERNE L. BOWERS
Major General, United States Army,
The Adjutant General.

Distribution:

To be distributed in accordance with DA Form 12-51 (qty rqr block No. 179) direct and general support maintenance requirements for the AN/GRC-106 Radio Set.